

MANDATORY

1. Applicability

Engine affected

Engine model	Production period / Serial number
Moster185 Plus	Manual and dual starter, delivered from June 2018 till December 2018.
Moster185 Silent	Manual and dual starter, delivered from June 2018 till December 2018.
Moster185 Factory	delivered from June 2018 till December 2018.

2. Reason

Following some isolated incidents in which the pilots have lost the airbox in the MY19 engine during the flight, ending up against the propeller and forcing the pilot to an emergency landing, VITTORAZI analyzed the information and the components received. The parts analyzed especially the rubber sleeve, the steel clamp and the rubber snap-lock were in correct condition after the accident.

3. Compliance

- Immediately, on undelivered engines.
- Before next flight, on the engine affected to avoid unusual engine operating behavior.

4. Subject

An investigation was carried out to understand what are the reasons and how to avoid it through correct procedure and additional safety devices.

- The new system requires to be disassembled every time to connect the fuel pipe.
- Access to tightening the metal clamp is not easy as the previous model.
- The clamp requires the correct tightening in order to guarantee a secure locking of the sleeve to the carburetor.

5. Labor time

Estimated labor: 20 minutes to install the safety belt system.

6. Mass data

Change of weight: 5 grams, the safety belt system.

SERVICE BULLETIN – MOSTER185

Safety conditions and devices of the MY19 Airbox



7. References

In addition to this technical information refer to current issue of:

- Engine user Manual
- Illustrated Parts Catalog

8. Material

Price and availability will be provided on request by VITTORAZI authorized dealer or Service Centers. Material requirement per engine:

Code / Art.	Quant.	Description	Cost of the material FOB
AGG2019-002	1	Safety strap	Free upgrade for engines affected

9. Rework of parts

Drilling the airbox and adding the rivet to lock the safety belt.

10. Special tooling

A 4.8mm bit for drilling the plastic airbox and hand rivet gun.

11. Alert conditions

More attention to the tightening of the sleeve, as described in the procedure below.

12. Accomplishment and Test Run

The work must be implemented and confirmed by at least one of the following persons:

- VITTORAZI MOTORS representatives;
- VITTORAZI MOTORS authorized Distributors, Service Centre, Aircraft manufacture.

At the end of the work to ensure the correct operation of the service a ground test is required and then a further approval in flight.

13. Inquires

Inquiries regarding this Service Bulletin should be sent to the VITTORAZI authorized Distributors, Service Centre, Aircraft manufacture of your area. A list of all VITTORAZI representatives is provided on the Vittorazi website (vittorazi.com).

SERVICE BULLETIN – MOSTER185

Safety conditions and devices of the MY19 Airbox

1P04-0017_02 - AIRBOX SAFETY STRIP UPDATE

Vittorazi Motors Via Marche 1 - 62010 Morrovalle (MC) - Italy Tel./Fax +39.0733.866585 Email: info@vittorazi.com

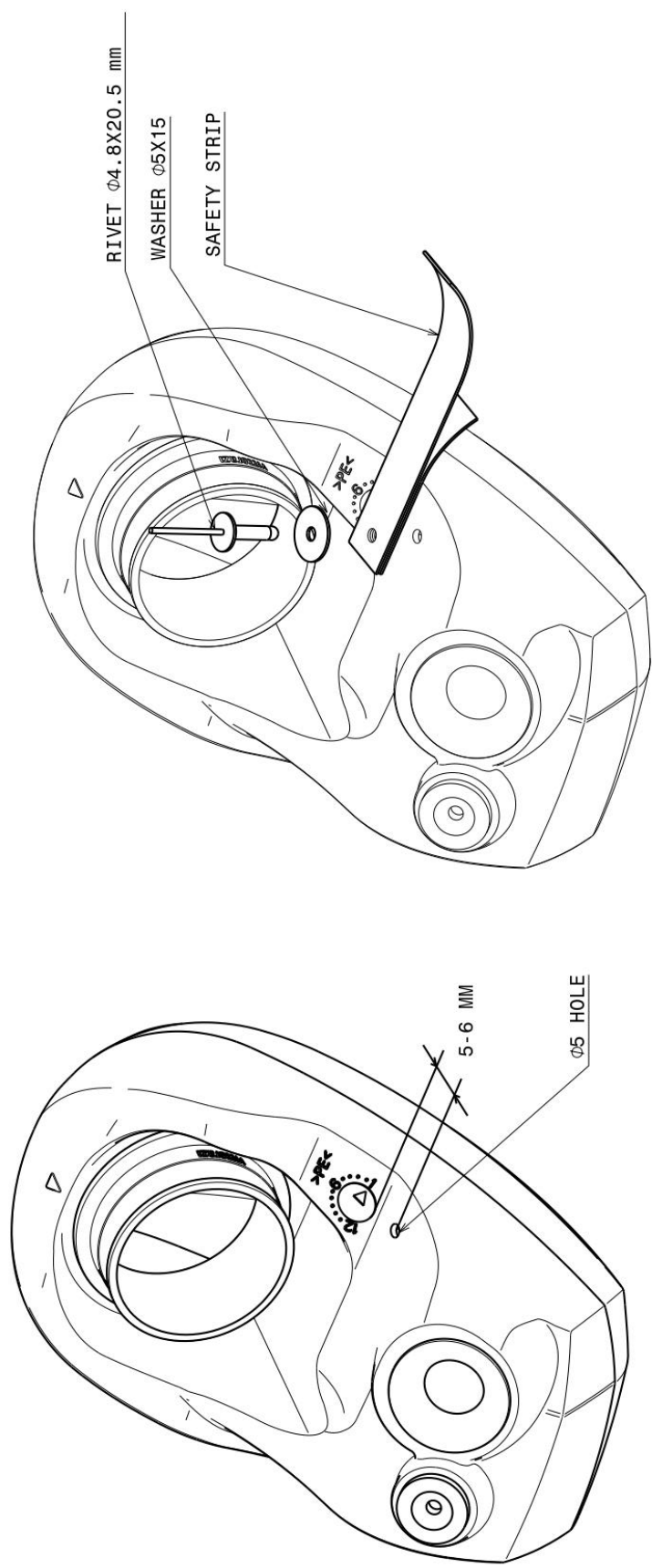

SERVICE BULLETIN – MOSTER185

Safety conditions and devices of the MY19 Airbox

1P04-0017_02 - AIRBOX INSTALLATION - 1/2

vittorazi
MOTORS

Vittorazi Motors
Via Marche 1 - 62010 Morrovalle (MC) - Italy
Tel./Fax +39.0733.866595 Email: info@vittorazi.com

1. Check alignment before tightening the hose clamp
2. Verify installation:
Push/Pull the airbox. There must be no relative motion between rubber sleeve and carburetor inlet flange.

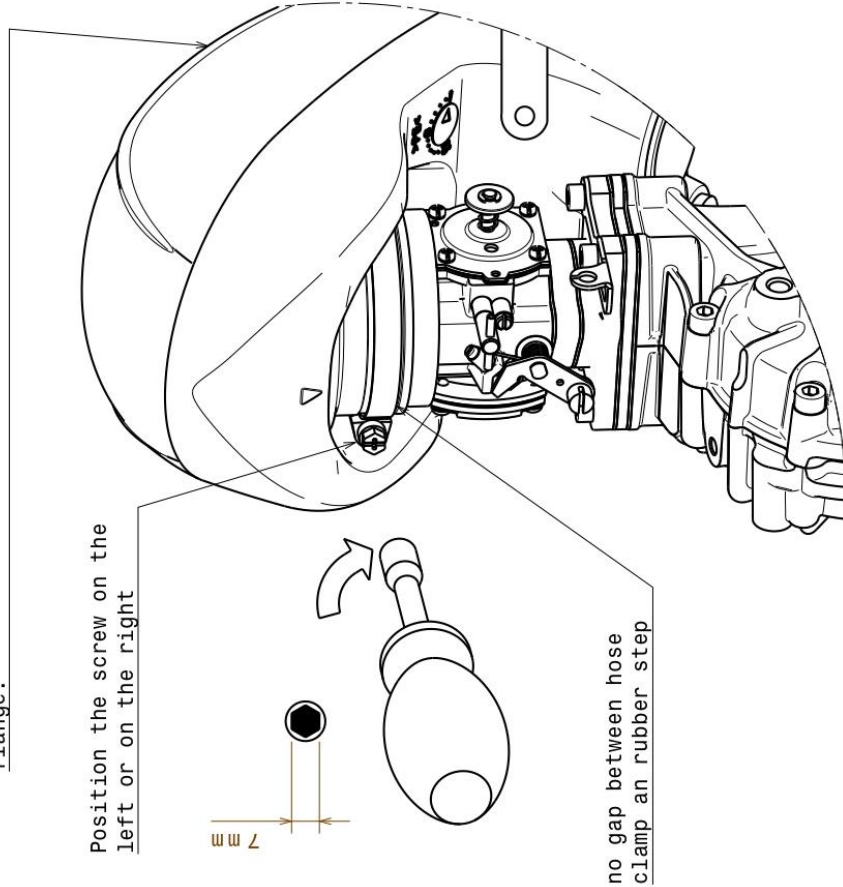

Tighten the hose clamp carefully:

1. use hexagonal screwdriver
2. apply 2,5 Nm torque
3. if you don't have a torque wrench
 - 3.1 tighten the hose clamp until it start squeezing the rubber
 - 3.2 apply 1 and $\frac{1}{2}$ more complete turns

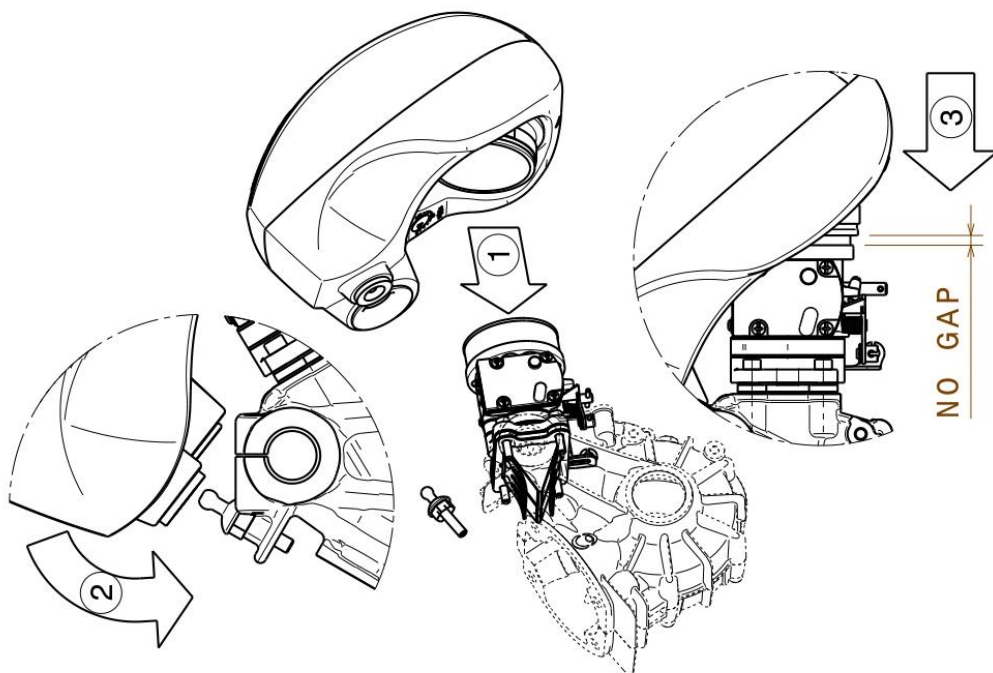

SERVICE BULLETIN – MOSTER185

Safety conditions and devices of the MY19 Airbox

1P04-0017_02 - AIRBOX INSTALLATION - 2/2

**VITTORAZI**
MOTORS

Vittorazi Motors
Via Marche 1 - 62010 Morrovalle (MC) - Italy
Tel./Fax +39.0733.866595 Email: info@vittorazi.com

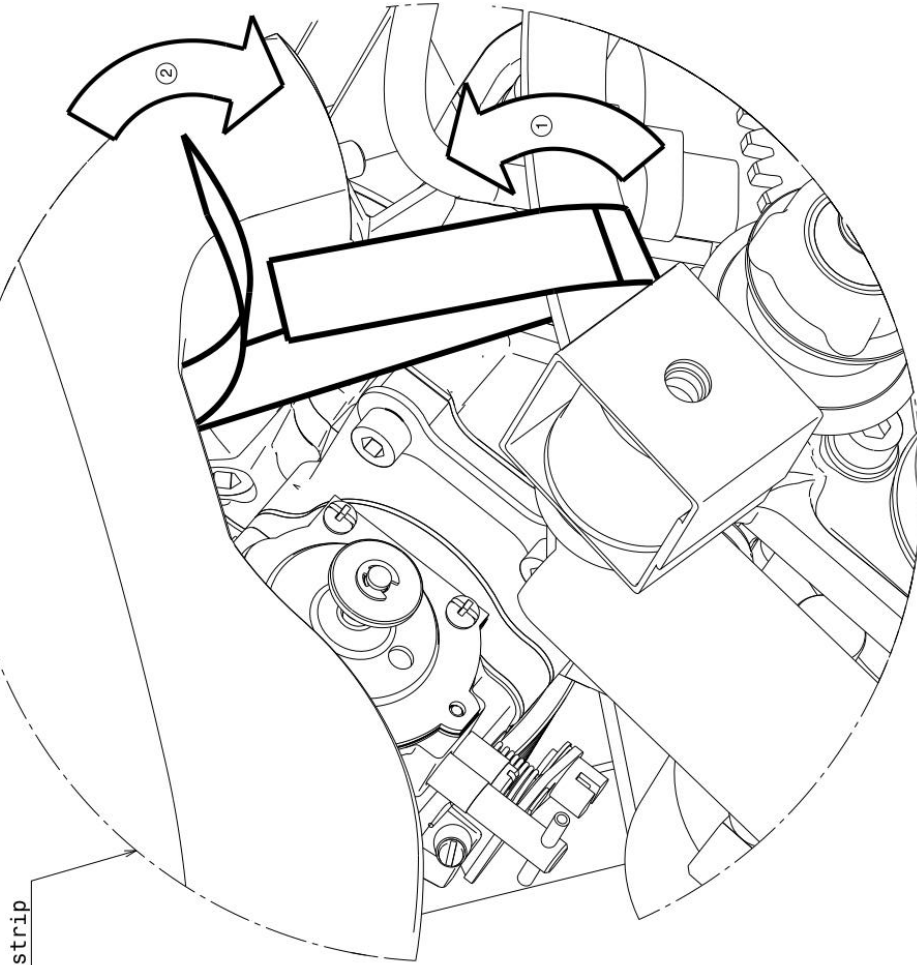

Apply safety strip

Notes:

- 1.a Position the safety strip on the aluminium frame between the coil and the silentblock
- 1.b Make sure that the strip is not loose
2. Close the second velcro strip
3. On engines with electric motor turn the throttle cable outward.

