

COSMOS 300

Maintenance manual

release V2/2023

Valid for MY23 versions

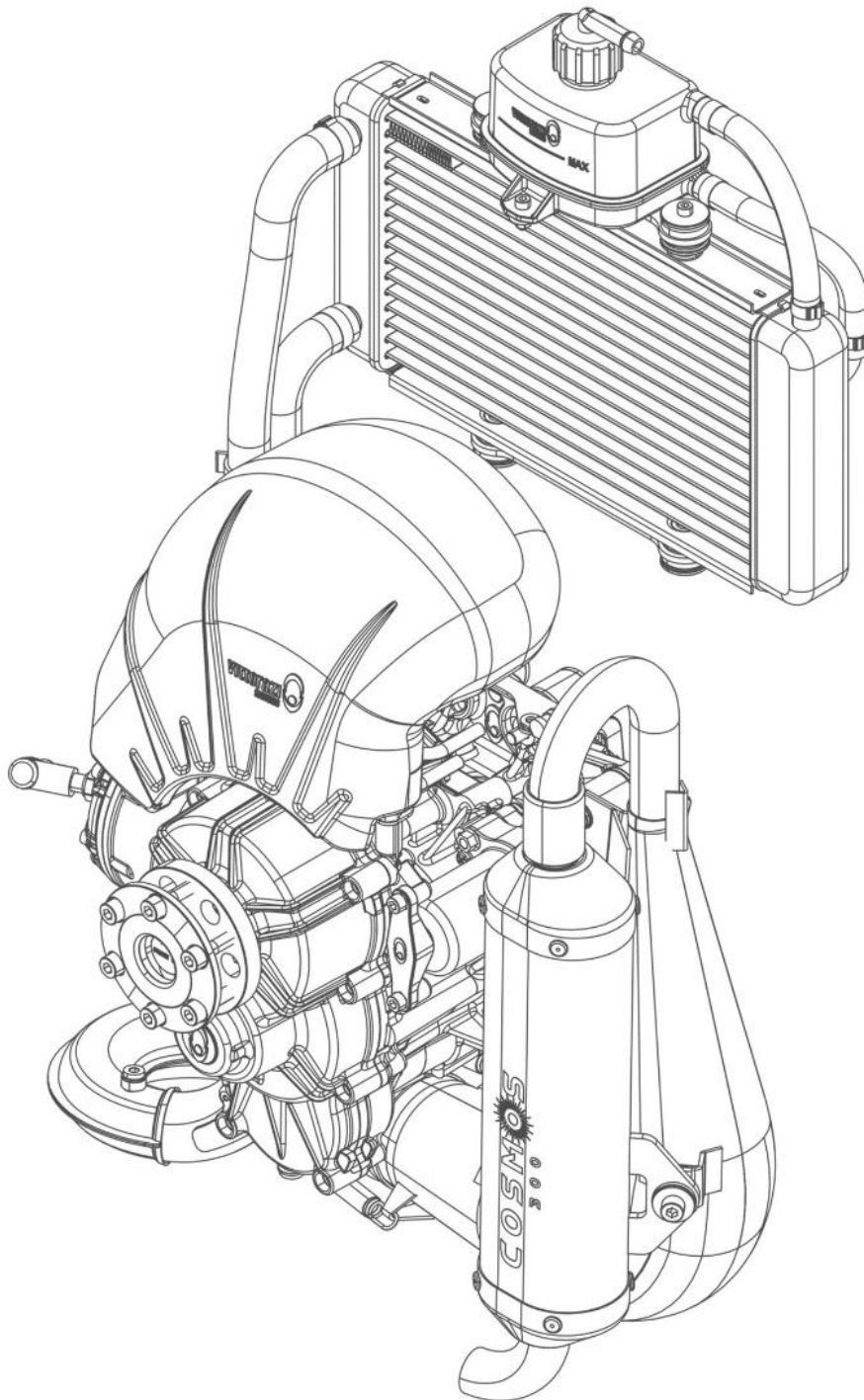

Contents

Contents	3
1 Introduction	6
2 Be careful! Read it completely	8
3 Maintenance	10
3.1 Maintenance schedule	11
3.2 Spark plugs	15
3.2.1 Spark plugs disassembly	15
3.2.2 Spark plugs maintenance	16
3.2.3 Spark plugs assembly	17
3.3 Airbox	18
3.3.1 Airbox disassembly	18
3.3.2 Airbox maintenance	21
3.3.3 Airbox assembly	23
3.4 Carburettor	26
3.4.1 Carburettor disassembly	26
3.4.2 Carburettor maintenance	28
3.4.3 Carburettor assembly	29
3.5 Reed valve	34
3.5.1 Reed valve disassembly	34
3.5.2 Reed valve maintenance	36
3.5.3 Reed valve assembly	37
3.6 Gaskets	39
3.7 Exhaust system	40
3.7.1 Manifold, exhaust bushing disassembly	40
3.7.2 Manifold, exhaust bushing maintenance	42
3.7.3 Manifold, exhaust bushing assembly	43
3.7.4 Silencer disassembly	46
3.7.5 Silencer maintenance	48
3.7.6 Silencer assembly	49

3.8 Cooling system	51
3.8.1 Cooling system emptying	51
3.8.2 Cooling system filling	55
3.8.3 Radiator rubbers disassembly	58
3.8.4 Radiator rubbers assembly	60
3.8.5 Cooling system maintenance	62
3.9 Rubber mountings	63
3.9.1 Rubber mountings disassembly	63
3.9.2 Rubber mountings maintenance	67
3.9.3 Rubber mountings assembly	68
3.10 Pull starter system	72
3.10.1 Pull starter system disassembly	72
3.10.2 Pull starter system maintenance	76
3.10.3 Pull starter system assembly	78
3.11 Electric starter	82
3.11.1 Electric starter disassembly	82
3.11.2 Electric starter maintenance	83
3.11.3 Electric starter assembly	84
3.12 Flywheel (and Bendix)	85
3.12.1 Flywheel disassembly	85
3.12.2 Flywheel maintenance	88
3.12.3 Flywheel assembly	90
3.13 Transmission	93
3.13.1 Oil replacement	94
3.13.2 Transmission disassembly	99
3.13.3 Transmission disassembly – ULM model	111
3.13.4 Transmission maintenance	124
3.13.5 Transmission assembly	128
3.13.6 Transmission assembly – ULM model	146
3.14 Piston, cylinder, head	167

3.14.1 Piston, cylinder, head disassembly	167
3.14.2 Piston, cylinder, head maintenance	171
3.14.3 Piston, cylinder, head assembly	173
3.15 Crankcase	181
3.15.1 Crankcase disassembly	181
3.15.2 Crankcase maintenance	188
3.15.3 Crankcase assembly	191
3.16 Tightening values	202

1 Introduction

Congratulations and thanks for being a Vittorazi qualified professional.

This manual is intended as a point of reference for aircraft manufactures, dealers, professional people dealing with Vittorazi Motors. Please study this professional manual carefully before starting the maintenance activity. The purpose of this manual is to provide all the necessary information to the professional in order to allow a proper maintenance of the engine, carried out autonomously and in total security. The professional manual includes: technical descriptions of the maintenance phase and reference values.

All the components of Vittorazi Motors are checked and tested in a process of industrial quality control before the assembling. Then by sampling the complete motors are checked to assure the functionality of all the parts through a complete test of twenty minutes on the bench. Note that the reliability, performance and durability of the engine also strongly depend on the correct maintenance of which you are in charge.

In case you need further explanations, you can contact directly the headquarters of Vittorazi Motors. Please include in the request, the six-digit serial number that identifies the motor and a photo of the item in question.

Also take into account the availability of Illustrated Parts Catalogue (IPC), manual updates, service bulletins, FAQs, other documents in our official website. The video tutorials are available on the Vittorazi Motors official YouTube channel. Below the links.

IPC, manuals, bulletins, newsletter, warranties, FAQ

<https://www.vittorazi.com/en/services/>



Vittorazi Official YouTube channel: video and free tutorials available

<https://www.youtube.com/user/VITTORAZIMOTORS>



Reading tips:

Attention, danger, risk
Any situation or condition which may result in a serious danger



Recommendation, warning, important advice



2 Be careful! Read it completely



To fly in total safety, you must read the following recommendations:

- This engine is not certified. This engine does not fulfil airworthiness regulations. The products are dedicated to non-certified aircraft and flying as a recreational or sporting activity.
- Final-user must be aware that the engine can stop, break or shut down at any time. Such an event may require an immediate and forced landing in inadequate, congested or impervious areas, with the possibility in the end of causing the death of the pilot or other persons involved.
- The aircraft equipped with this engine must be conducted in full compliance with rules and regulations in force relating to the activity of leisure and sport aviation, with regard to the country in which the operations are carried out.
- Vittorazi Motors and its distributors decline any direct or indirect responsibility related to this kind of activity. By using a new engine, the owner agrees that these terms and conditions have been accepted at the time of purchase of the product.
- The engine is not covered by any liability insurance. The use of the engine automatically determines the assumption of all risks and personal liability for personal injury or damage to third parties resulting from the activity.
- Improper use of the products or improper technical service (in relation to the specifications contained in the user, installation and maintenance manual) will hold harmless the company from any liability for any damage due to the malfunctioning and immediately void the warranty of the product. So, do not use the motor if it has not been properly maintained or if it has not been used correctly over time.
- Vittorazi does not assume any responsibility for those engines that are used with parts that are not original, not approved, modified or that have suffered an improper use. Use of spare parts not original and not recognized by Vittorazi, can make the engine dangerous and will void the warranty.
- Unauthorized modifications to the motor, to the reduction, to the propeller can invalidate the warranty of the motor and can compromise the reliability of the aircraft and its safety. In case it is necessary to intervene, we invite you to contact an authorized dealer Vittorazi.
- Some geographical areas, due to particular weather conditions such as pressure, temperature and humidity can affect the performance of the engine. Before taking off, test the engine on the ground and make sure it does not behave abnormally.

- Always start the engine on a flat and clean surface, without stones or sand. During all phases in which the engine is kept running near the ground (such as heating, take off, landing) it is necessary to maintain a safe distance from the engine. A good safety distance is 100 meters in every direction.



The following engine speed limits must be respected to avoid engine failures, to keep the warranty valid and to have a correct maintenance scheduling according to the Vittorazi program:

- Do not keep the engine at full revs for more than 60 seconds.
- Do not keep revs higher than 6.500 RPM during long cruising flights or long climbs. The average power delivered by the engine during a flight should remain below the indicated threshold. Contact the aircraft manufacturer for further clarification.



For the proper engine operation, the coolant temperature measured by the head sensor must be within the limits indicated below. In case of a temperature outside the indicated thresholds (Min; Max), contact the aircraft manufacturer.

- Max 90 °C.
- Min 65 °C.



The temperature limit of EGT is 650° Celsius. Do not persist above this temperature threshold, engine overheating and irreversible damage could occur.

3 Maintenance

To ensure a safe, long-lasting product and to keep the warranty valid, the user must follow a maintenance schedule as outlined in the manuals and record the service work in the service booklet (available in the Warranty chapter of the user manual). An hour meter integrated in the aircraft is required, always working and well installed to the engine.

Any procedure of installation, maintenance and/or repair of the products must be carried out exclusively with the original Vittorazi Motors parts and tools specified by Vittorazi, in compliance with the specifications contained in the user, installation and/or maintenance manual of the products; to ensure maximum safety and performance of the products, the above-mentioned procedures will be carried out by mechanics with proven experience in the ultralight aviation or general aviation or with experience gained by Vittorazi Motors professional training courses. Failure to do so, will held harmless the company from any liability for any damage due to the malfunctioning and immediately void the warranty of the product.



Maintenance work must be carried out when the engine is cold.

3.1 Maintenance schedule

Refer to the following maintenance indicated time schedule to fly in total safety. Work on the engine is only allowed to be carried out by experienced mechanic and authorized dealers. These are prescribed checks at certain interval times to avoid engine problems through preventative maintenance.

Caption:



Cleaning



Check



Measuring





















Replacement





















Lubricate with WD-40

Note:













- 1) or after a year
- 2) rope, spring, hooks or a new pull starter system
- 3) springs
- 4) each time the component is disassembled
- 5) head, exhaust port, decompressor hole
- 6) when the hoses are disassembled replace the clamps
- 7) or after 2 years

Flight hours	Before each flight	Every 10 h	Every 25 h	Every 50 h	Every 100 h	Every 150 h	Every 200 h
Pre-flight checklist							
Screws and nuts (tightening)							
Carburation from spark plug colour							
Spark plugs							
Spark plugs connectors							
Carburettor							
Carburettor membranes						 1)	
Airbox Snaplock							
Airbox			 				
Airbox sponge and sleeve			 		 1)		
Reed valve petals							
Pull starter system					 2)		



The table follows in the next page

Flight hours	Before each flight	Every 10 h	Every 25 h	Every 50 h	Every 100 h	Every 150 h	Every 200 h
Electric starter							
Kit exhaust bushing (1 st joint)							
Exhaust bushing (2 nd joint)				  3)			
Exhaust manifold with springs							
Soundproofing material silencer							
Silencer rubbers						 1)	
Gaskets (head, cylinder, carburettor, reed valve, exhaust, transmission, water pump)					 4)		
Piston					 		
Piston roller bearing							
Head and cylinder					 5) 		

The table follows in the next page

Flight hours	Before each flight	Every 10 h	Every 25 h	Every 50 h	Every 100 h	Every 150 h	Every 200 h
Coolant						 1)	
Radiator hoses					 6)		
Radiator rubbers							 7)
Rubber mountings (engine, exhaust)						 1)	
Oil seal carter case							
Crankshaft bearings							
Crankshaft							
Gearbox oil							
Transmission bearings							
Centrifugal clutch							
Clutch bell							

3.2 Spark plugs

 Components to replace		
	Spark plugs (M020)	Time limit 25 h
 Special tools	Not required.	
 Values	Spark plugs: 25 Nm.	

3.2.1 Spark plugs disassembly

Disconnect the connector and unscrew the spark plugs.

3.2.2 Spark plugs maintenance

Check the colour of the spark plugs: see user manual.

Use a feeler gauge to measure the distance between the spark plugs electrodes.

Worn spark plug limit (mm)
0,9

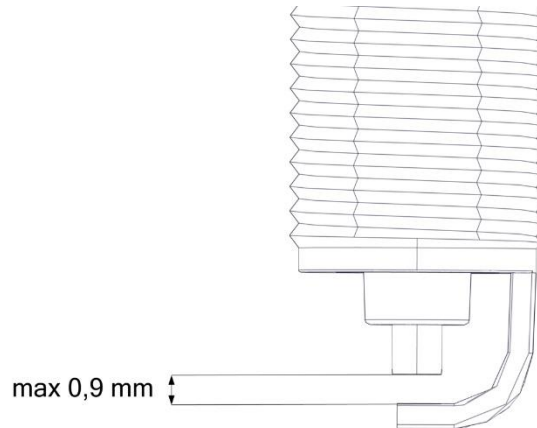

If the distance between the electrodes is equal to or greater than the indicated limit or if scheduled maintenance is required, replace the spark plugs.



The new spark plugs for the engine must be of the same type and rating as the ones to be replaced (NGK BR9ES).

Check the connectors: if they are damaged or the connection to the spark plugs is not stable, replace them.

Check the ignition cables: there must be no cuts or cracks, otherwise replace the ignition coils (including ignition cables).

3.2.3 Spark plugs assembly



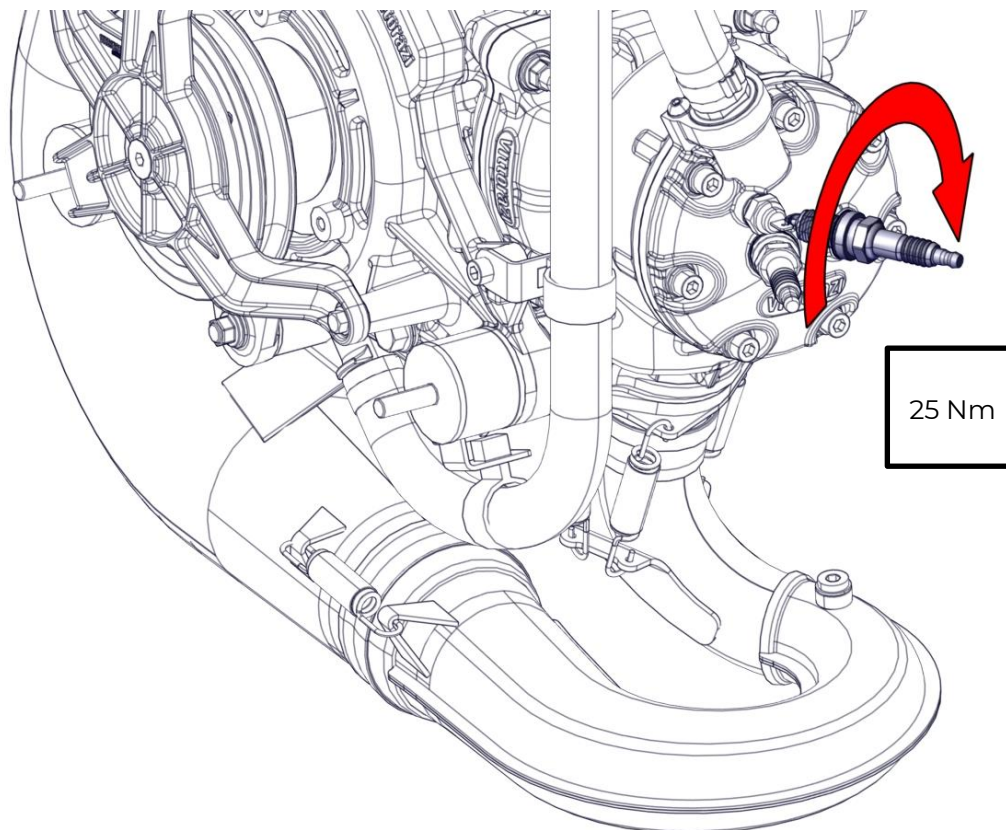

The distance between the electrodes of the new spark plugs must be 0,7 mm, otherwise adjust.

Screw the spark plug into the head and tighten with the torque shown in the figure.



3.3 Airbox

 Components to replace		Time limit
	Sleeve with filter (AT093a)	100 h or 1 year
	Snaplock (MP093d)	50 h
 Special tools	Not required.	
 Values	Clamp screw: 2,5 Nm.	

3.3.1 Airbox disassembly

Unhooking the safety strap from the back support.

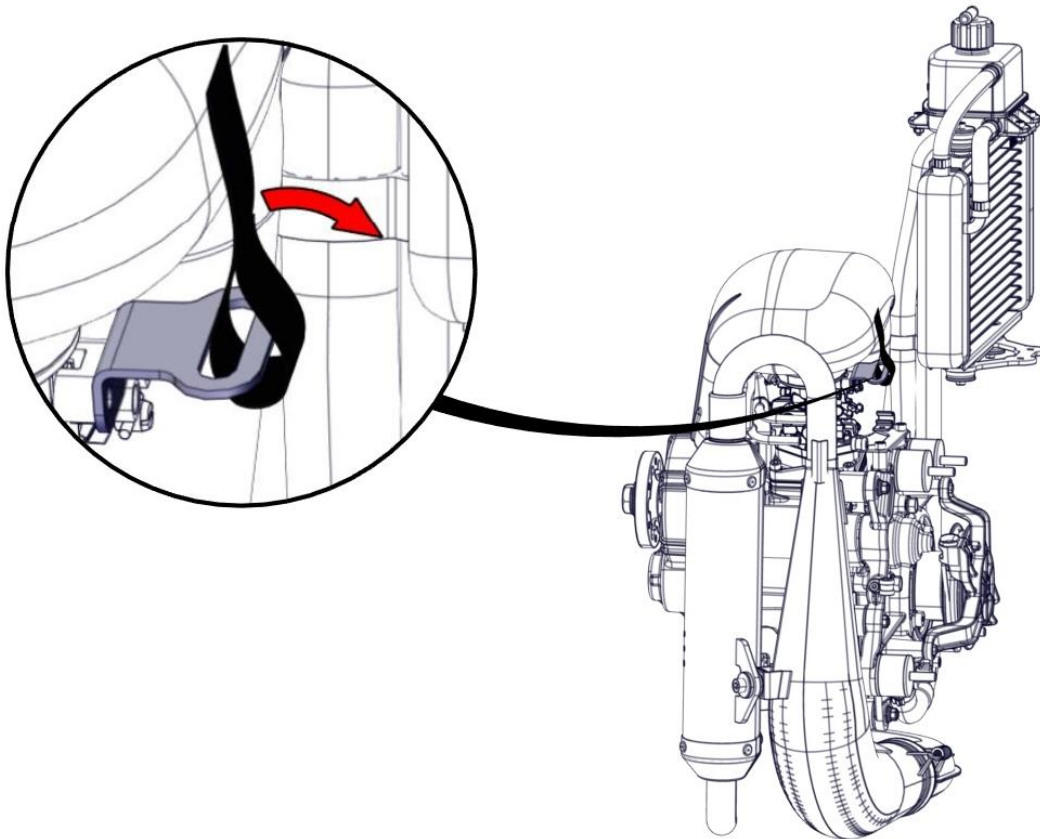

Loosen the screw of the clamp securing the sleeve to the carburettor.

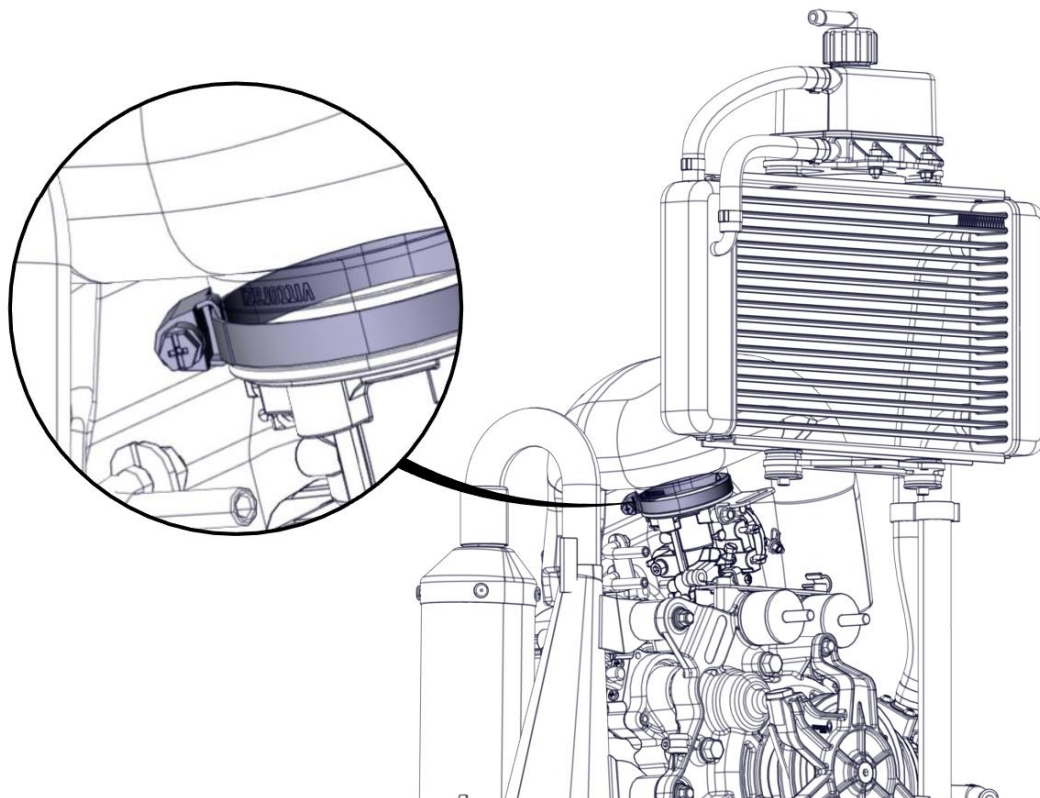

Remove the airbox by disconnecting the 2 Snaplocks.

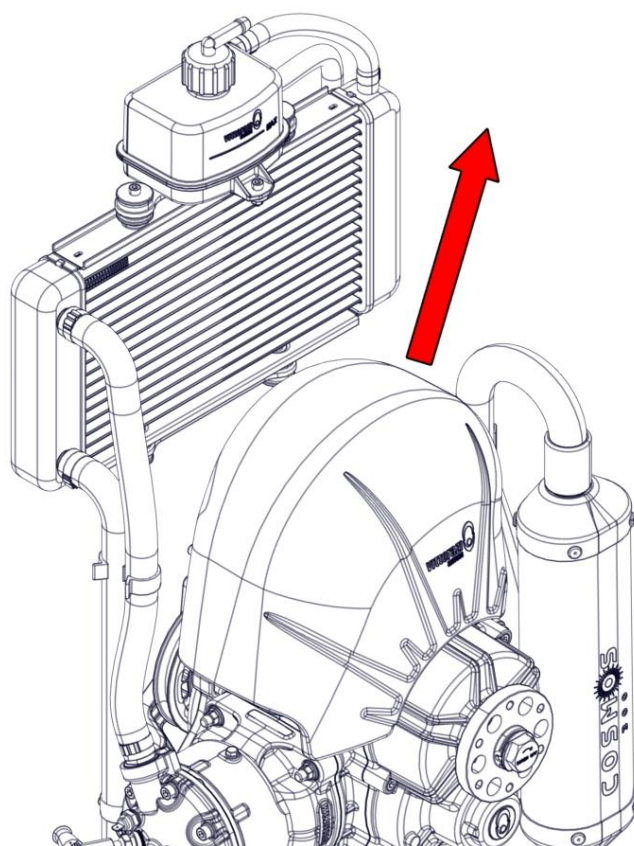

Fold the sleeve inwards and remove it from the airbox.
Remove the 2 Snaplocks.

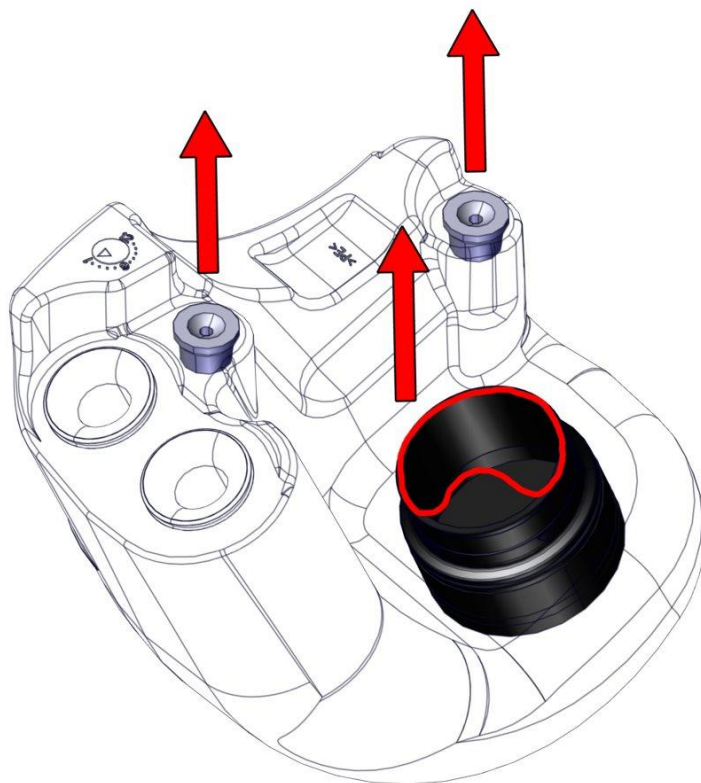

3.3.2 Airbox maintenance

Clean the sponge with specific filter chemicals. Clean the airbox cavity with compressed air. To obtain a good seal between the components, degrease the connector of the Airbox (1) and the internal part of the sleeve (2) with a product suitable for cleaning rubber (the sleeve is made up of a mixture of NBR and PVC).

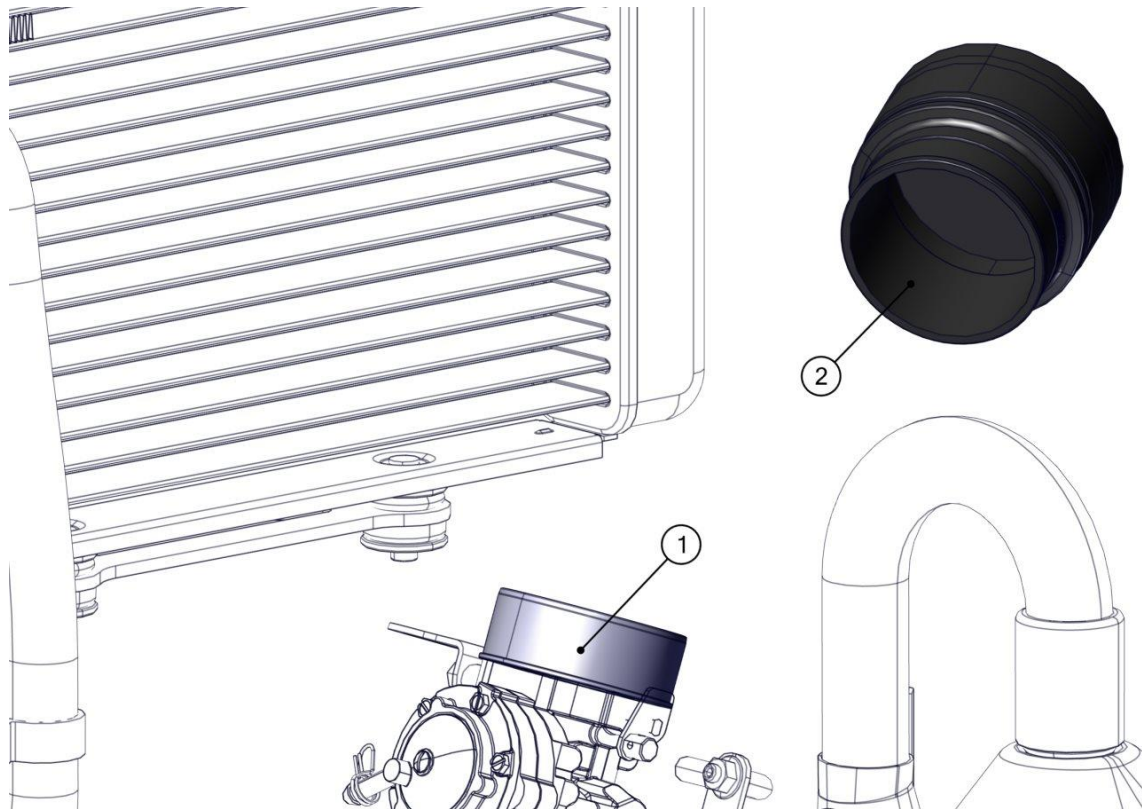

Check the integrity of the airbox.
Check the sleeve groove.



Check the filter, in particular the bonding with the sleeve and the various parts of the sponge.



Check the Snaplock, in particular the central hole (the photo shows a comparison between a new component on the left and a worn one on the right).
Connect the Snaplock to the pin on the motor to check that the engagement is stable.

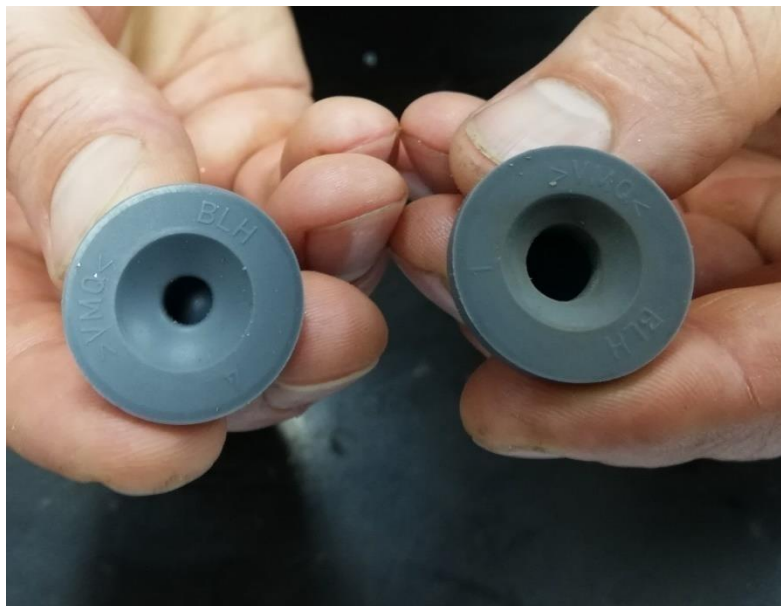

If the above components are damaged, replace them immediately. For routine maintenance, follow the table.

Use extreme caution when checking, as failure to replace damaged components can lead to detachment of the airbox and impact with the propeller.

3.3.3 Airbox assembly

Insert the sleeve into the airbox. Insert the Snaplocks.

Connect the airbox sleeve to the carburettor inlet flange and 2 Snaplocks to the pins fixed on the engine.

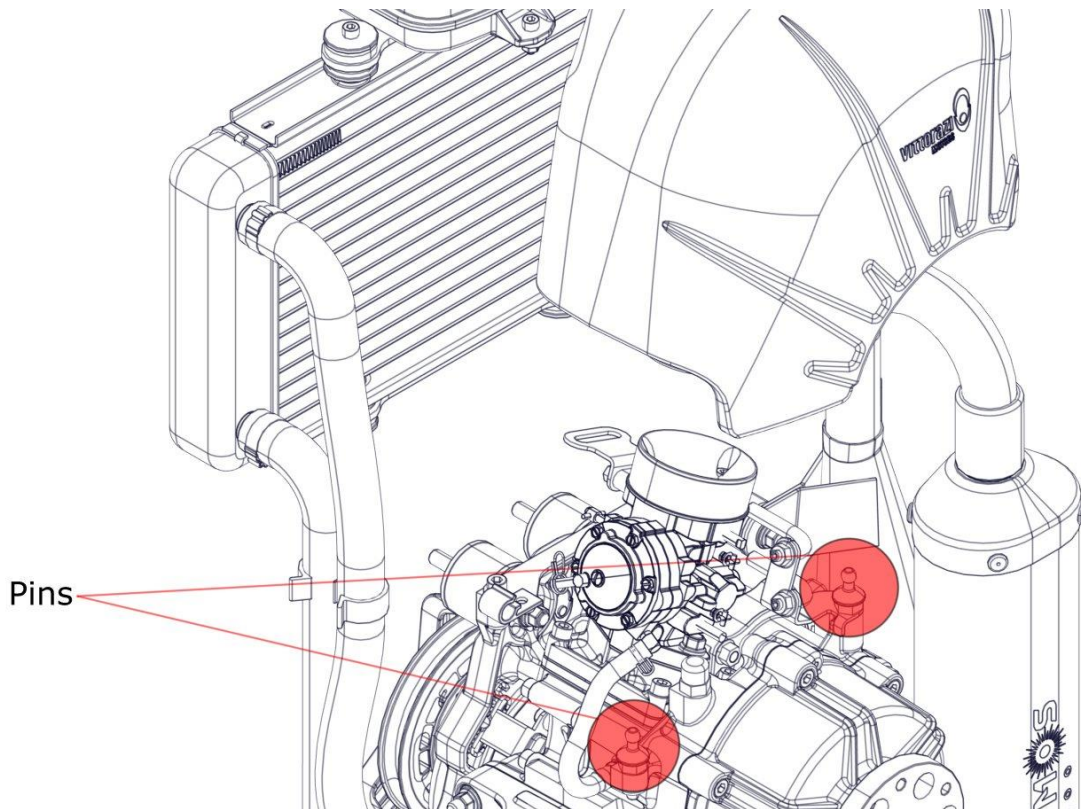
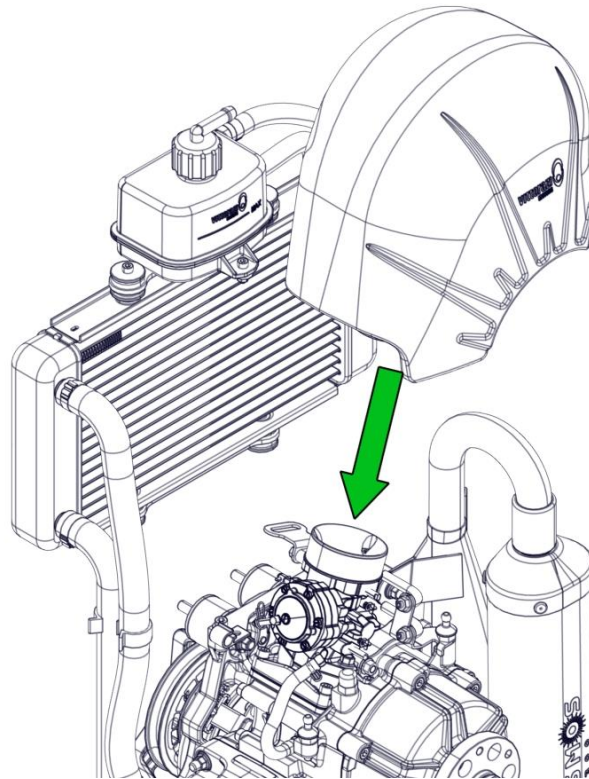

Check the position of the fixing clamp and the screw.

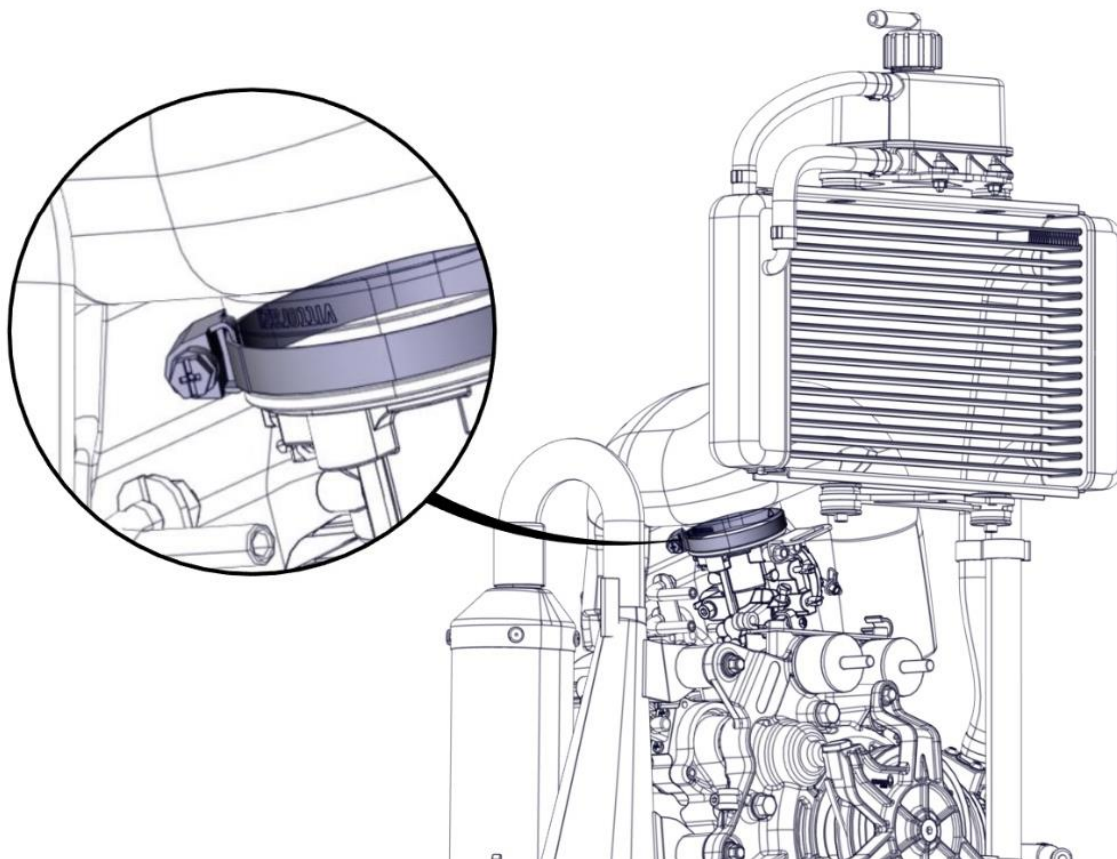

The airbox sleeve (1) must be completely inserted into the airbox connector (2), the fixing clamp (3) correctly inserted on the seat and aligned as in the figure.

Tighten the fixing clamp by applying the torque shown in the figure.

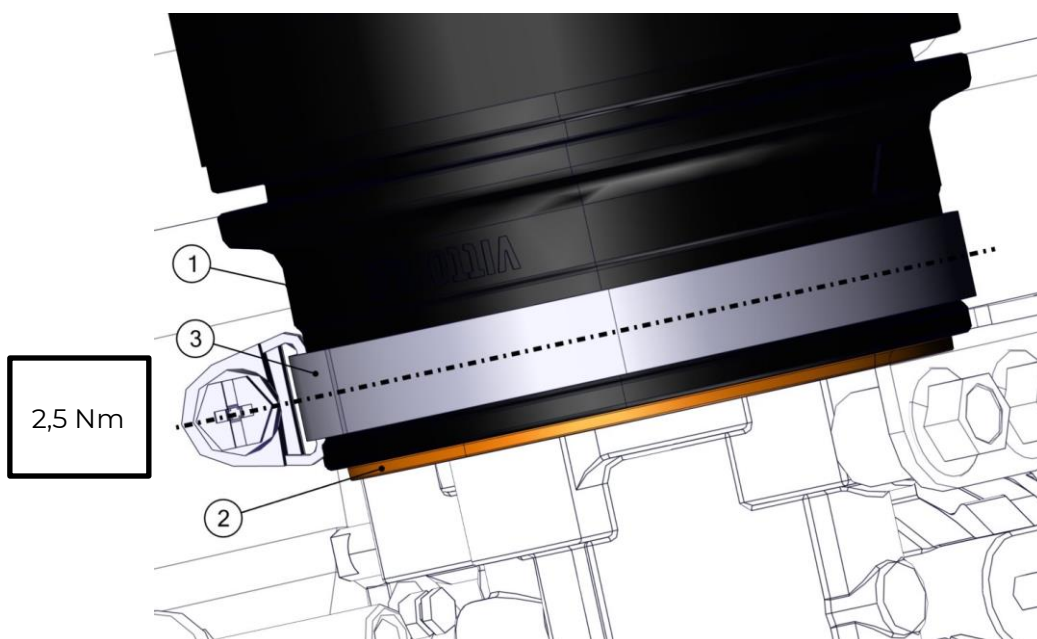



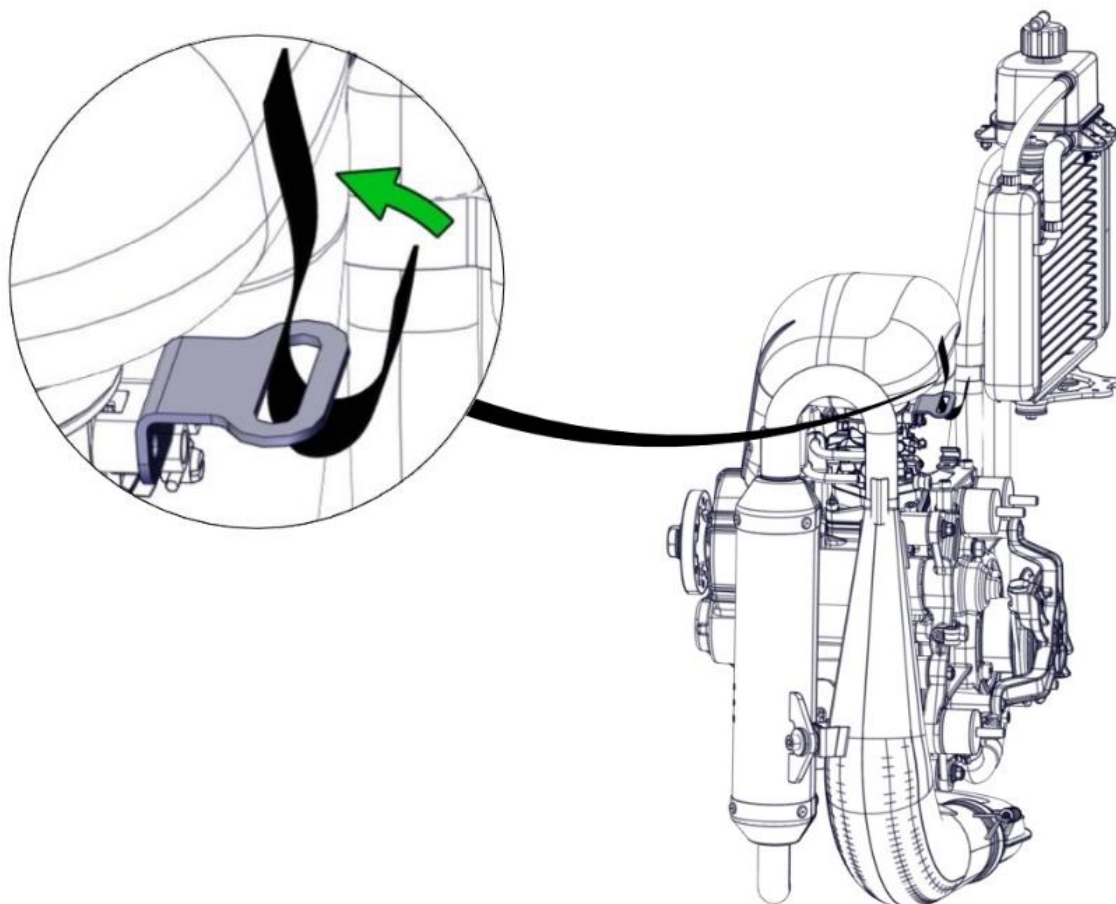

Attach the safety strap to the support bracket behind the airbox, ensuring that the strap is tightened firmly.



After installation, check that there is no relative movement between the rubber sleeve and the airbox connector.

3.4 Carburettor

 Components to replace		Time limit
	Gasket* (C088)	150 h
	Internal carburettor diaphragms and gaskets (C097)	150 h or 1 year
	Self-locking nuts M8* (C087)	150 h
	Pulse line hose (C096)	on condition
 Special tools	Pressure tester (ACC130).	
 Values	Self-locking nuts M8: 16 Nm. Metering lever opening pressure: 0,6 - 0,8 bar	

*Always replace it when disassembled.

3.4.1 Carburettor disassembly



Before disassembling the carburettor, remove the fuel line and the airbox (3.3 Airbox).

Remove the double wire hose clamp from the pulse line hose and disconnect the hose.

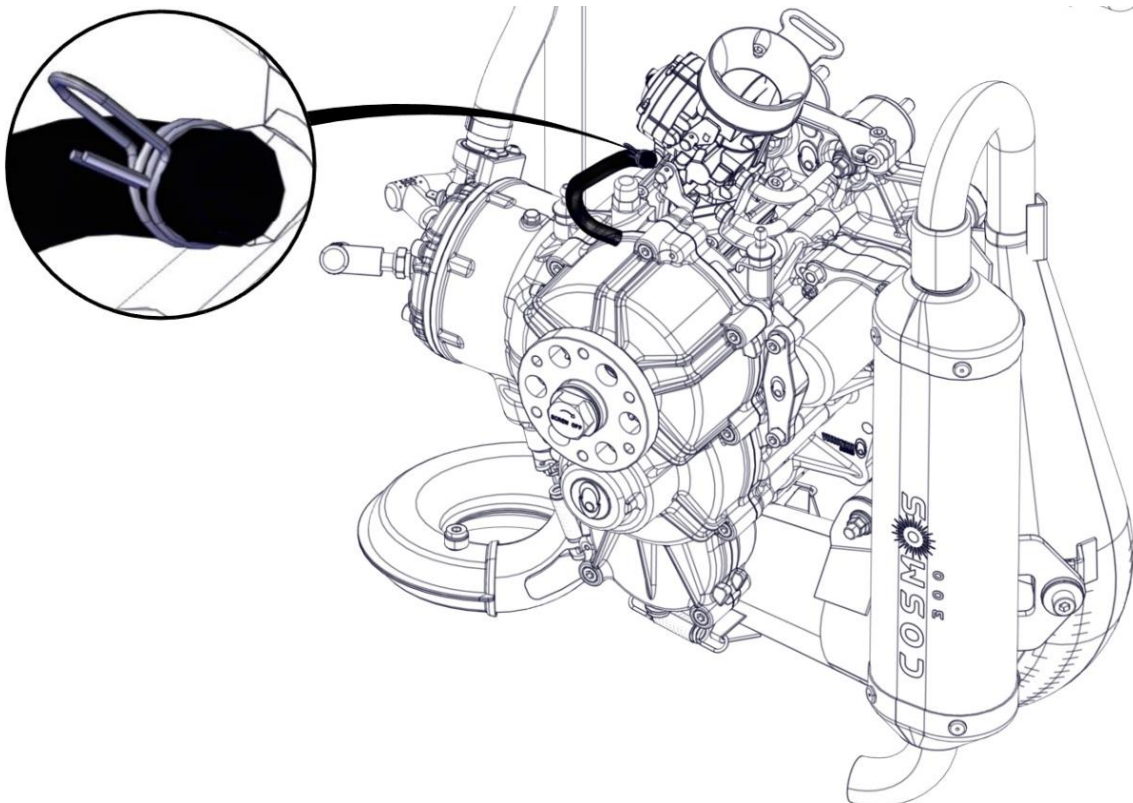

Remove the 4 Allen screws M6x30 (1) from the carburettor flange (2).
Remove the carburettor flange (2).

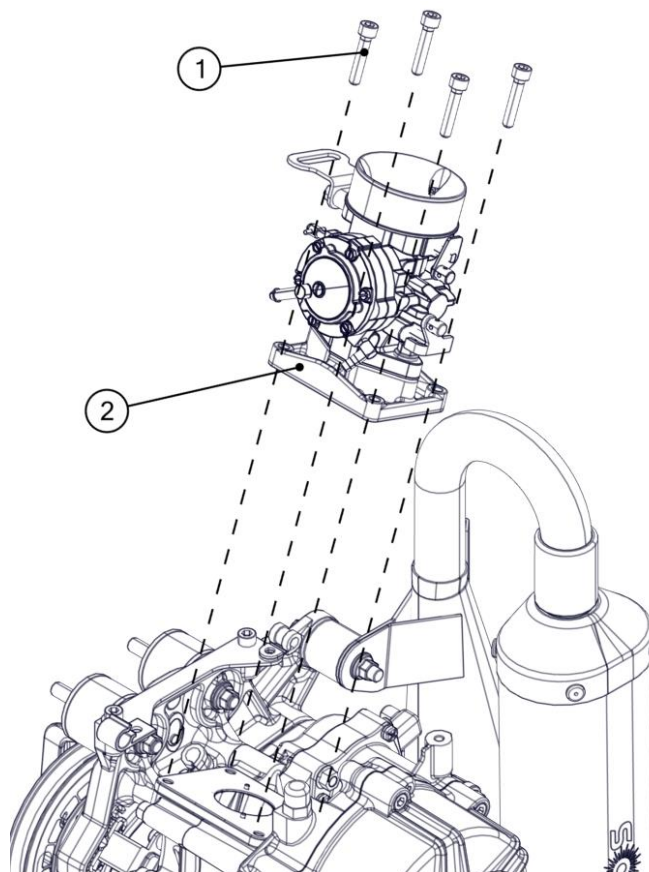

Remove the 2 self-locking nuts M8 (3) at the base of the carburettor.
Remove the carburettor (4) and the gasket (5).

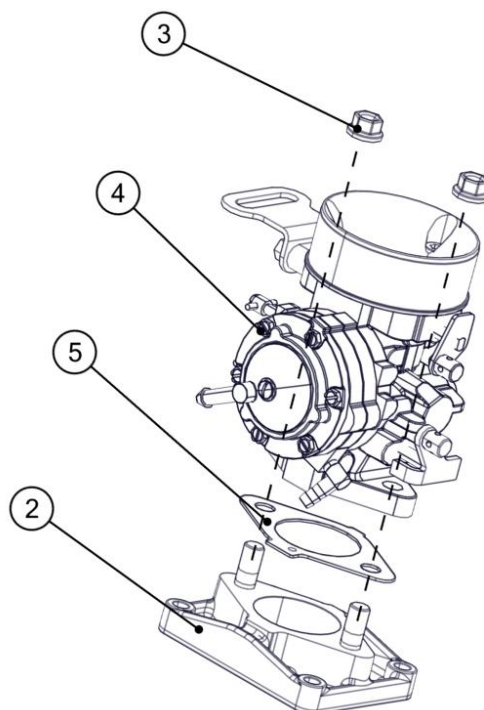

Disassemble the carburettor by removing the components.

3.4.2 Carburettor maintenance

Immerse the carburettor case in a container containing cleaning liquid for a few minutes. Carefully clean the carburettor body and covers with a brush, removing any gasket residue. Then gently blow the various parts with compressed air.

Pay particular attention to cleaning the metering lever needle.

Check the condition of the diaphragms: they must be soft and free of cuts, otherwise they must be replaced. For routine maintenance, follow the table.

Check the pulse line hose: there must be no cracks or damaged areas, otherwise replace it.

3.4.3 Carburettor assembly

Check metering lever: 2,4 mm

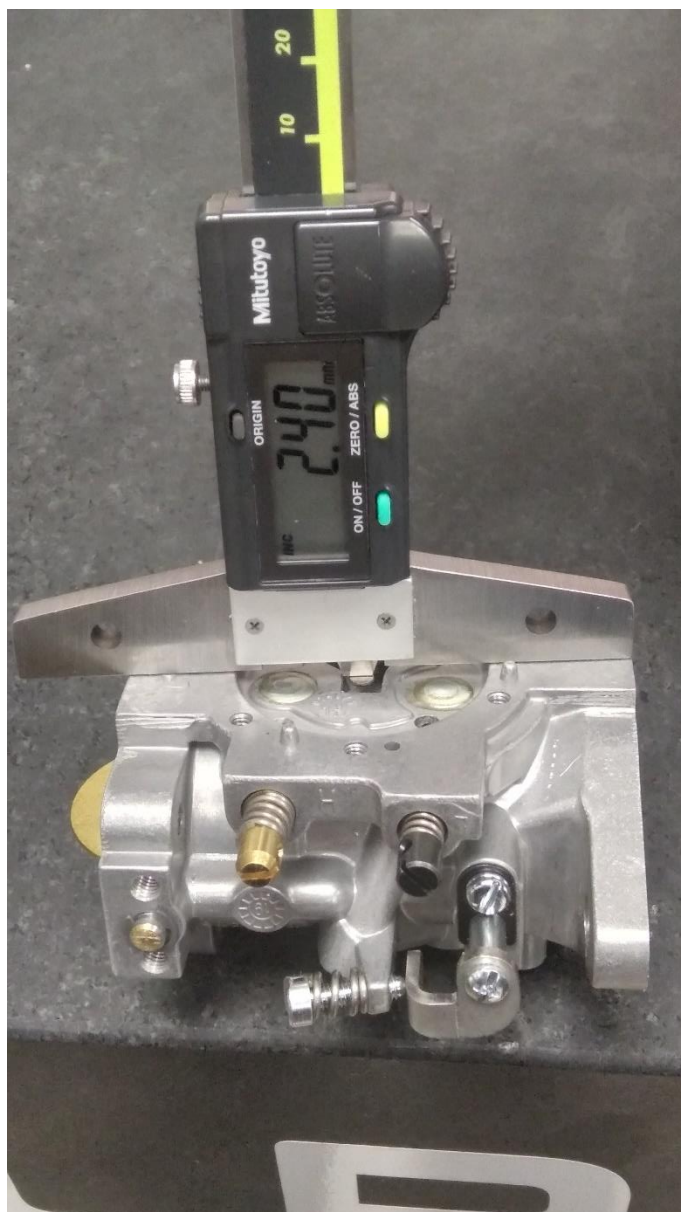

Replace the diaphragms and gaskets.



Observe the assembly order of the components shown in the figure. Incorrect assembly will impair the operation of the carburettor.

Assemble the carburettor components.

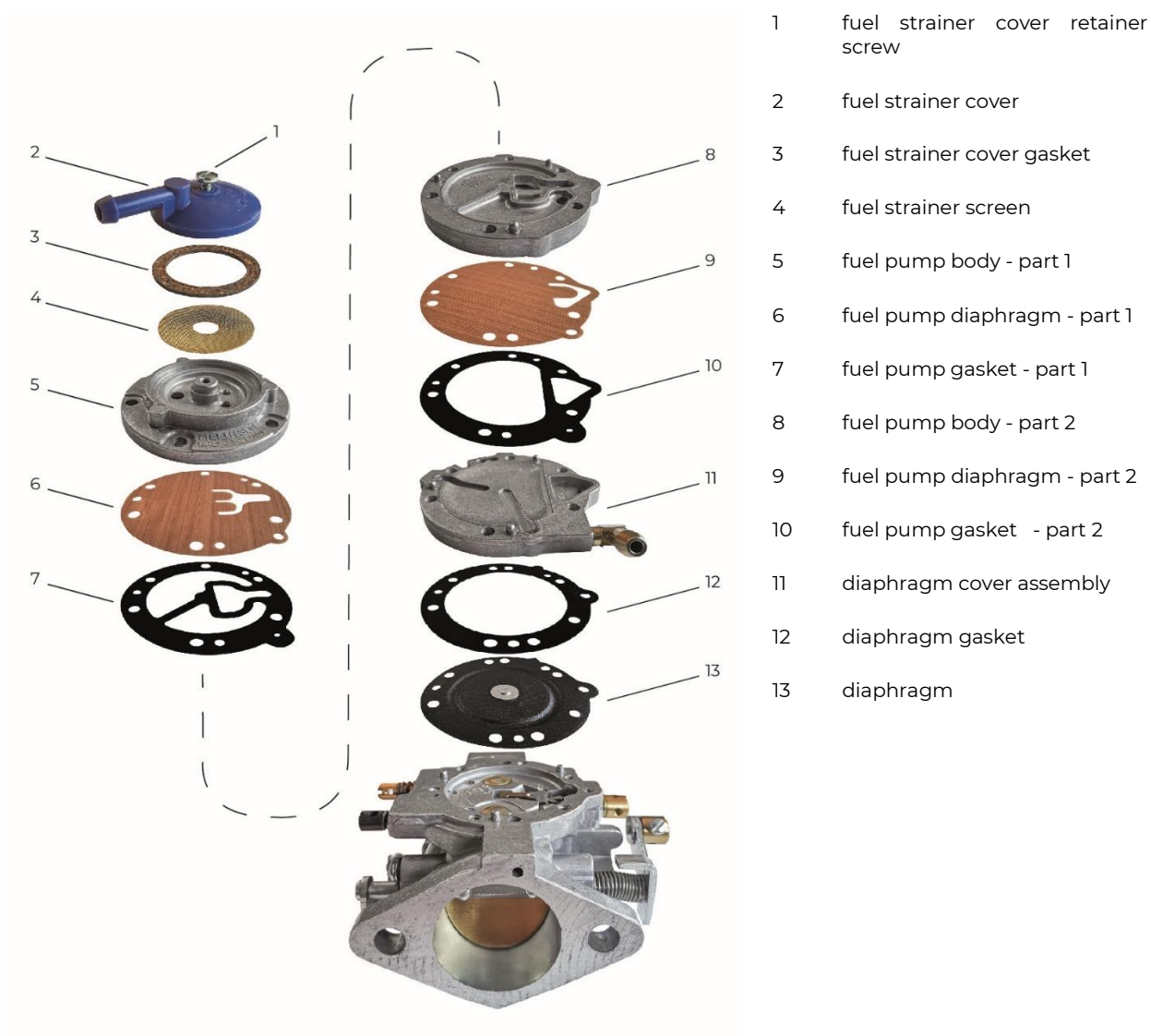

Connect the carburettor's fuel inlet pipe (highlighted in the figure) to a pressure tester [ACC130] via a tube.

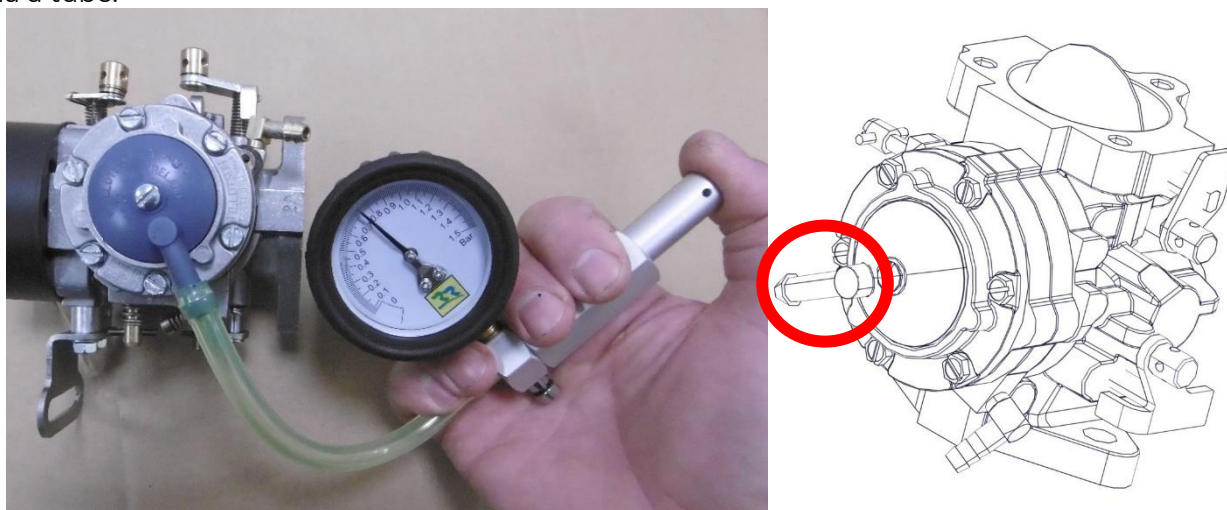

The carburettor pressure test must be carried out with air.
Check that there is no gasoline in the carburettor before carrying out the test.

Gradually increase the pressure and check that the needle of the metering lever releases air at the pressure values indicated in the table.

Vittorazi factory settings (bar)
0,6-0,8

In the event of a fault, measure the height of the metering lever again and replace the spring if necessary.



Replace the gasket (5) and the 2 self-locking nuts M8 (3) each time they are disassembled.

Position the gasket (5) and the carburettor (4).
Screw the 2 M8 self-locking nuts (3) onto the stud bolts at the base of the carburettor and tighten with the torque shown in the figure.

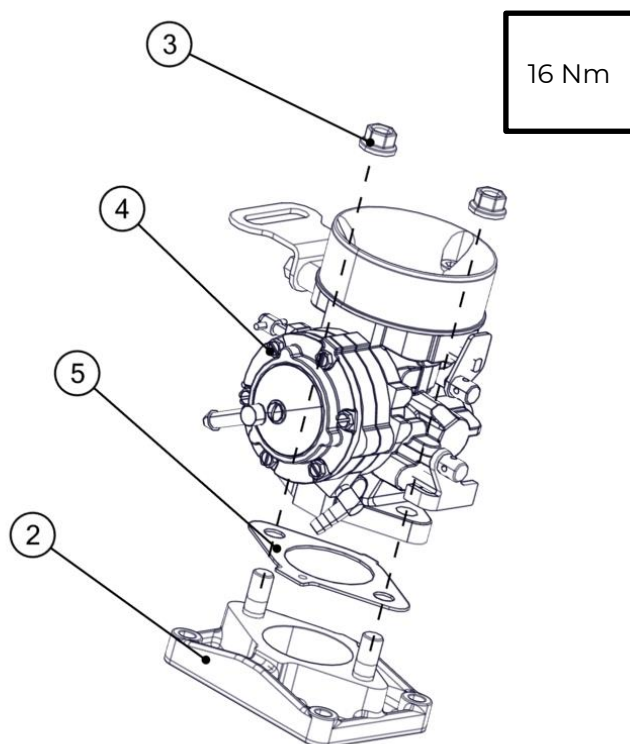

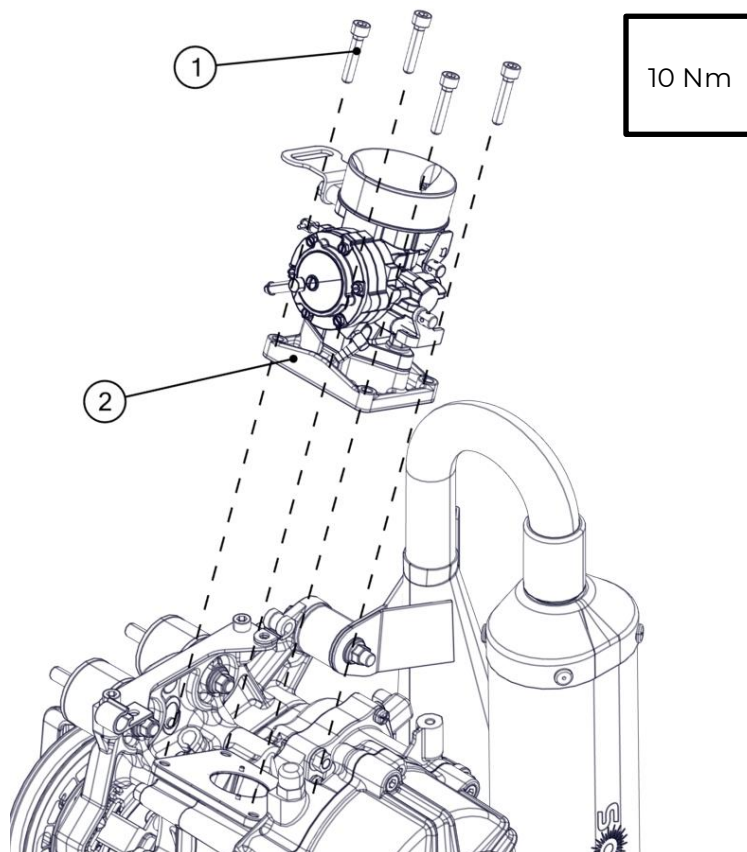

Insert the 4 Allen screws M6x30 (1) into the carburettor flange (2), tighten progressively, then tighten with the torque shown in the figure.

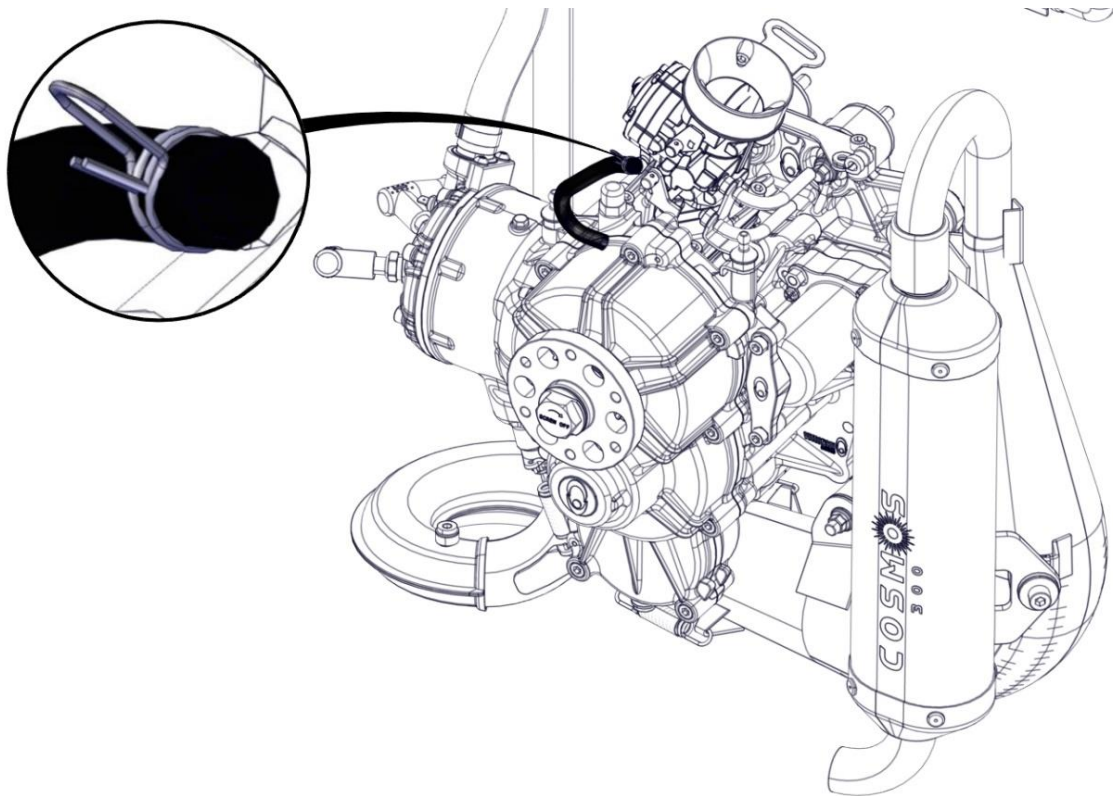

Connect the pulse line hose to the carburettor and secure it with the double wire hose clamp.



3.5 Reed valve

 Components to replace		Time limit
	Petals (C082)	50 h
	Gaskets* (C083a)	50 h
	O-ring (C085a)	50 h
 Special tools	Not required.	
 Values	Screws M6x30: 10 Nm.	

*Always replace it when disassembled.

3.5.1 Reed valve disassembly



Before disassembling the reed valve, remove the airbox (3.3 Airbox).

Remove the double wire hose clamp from the pulse line hose and disconnect the hose.

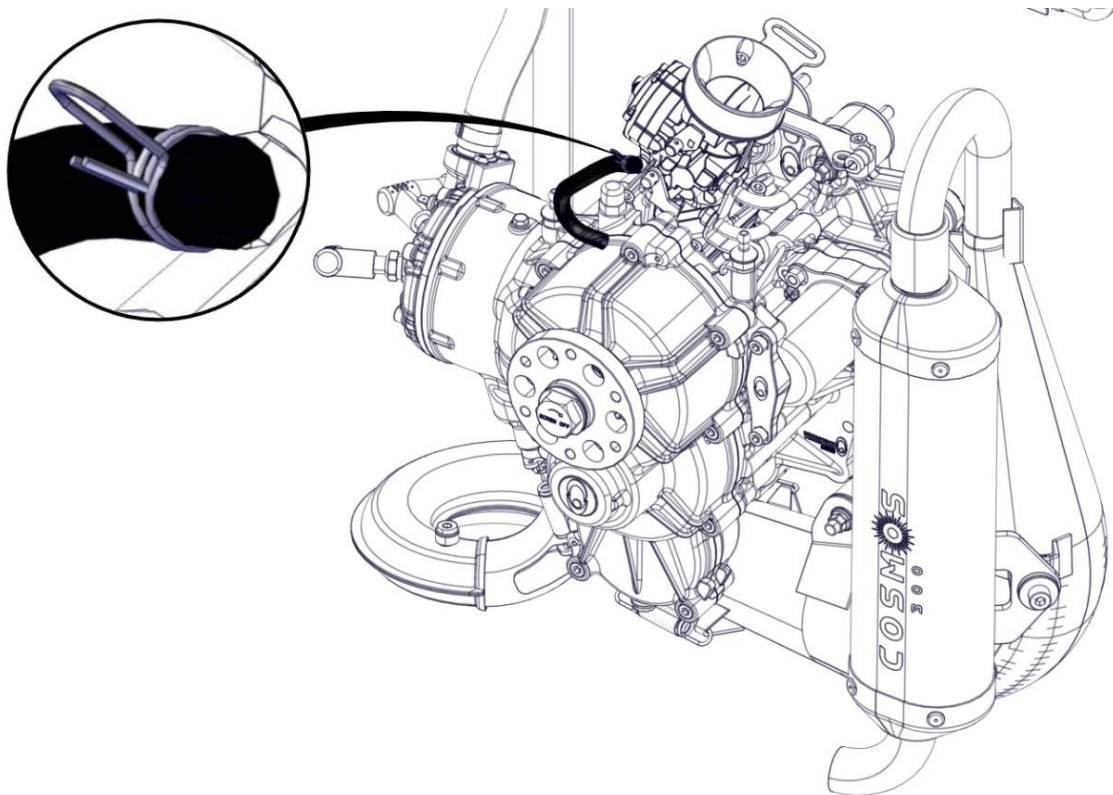

Remove the 4 Allen screws M6x30 (1) from the carburettor flange (2).
Remove the following components from the engine casing (8): carburettor flange (2), flange gasket (3), O-ring (4), flow guide (5), reed valve (6), reed valve gasket (7).

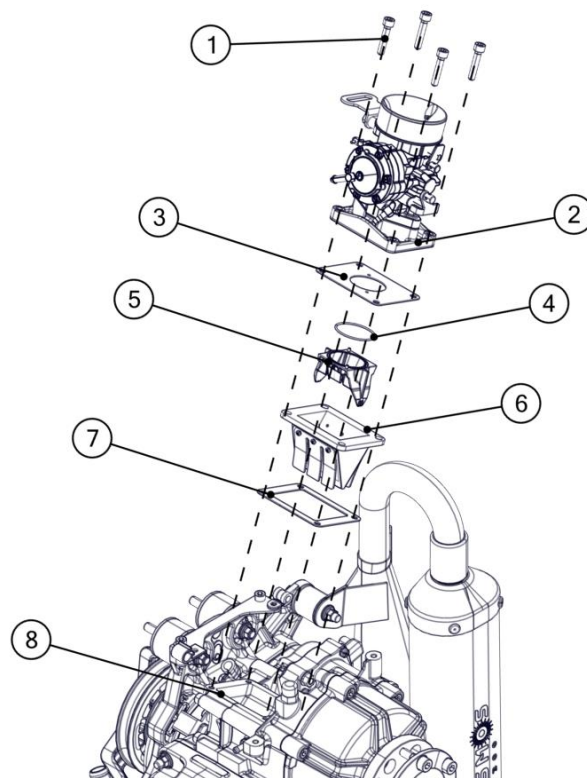

Remove the 3 Phillips screws M3x6 (9) from one side of the reed valve.
Remove the stoppers (10) and petals (11).

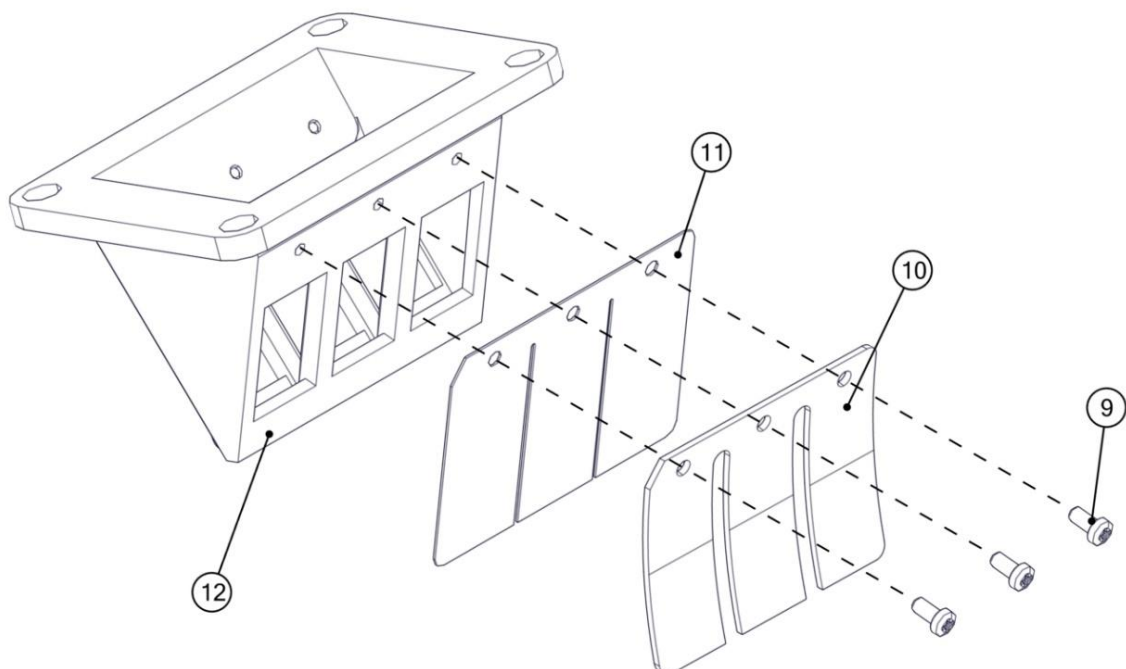

Carry out the same operations on the other side of the reed valve.

3.5.2 Reed valve maintenance

Check the petals: they must be intact (the photo shows a typical break on worn petals).



Also check that the petals are not deformed: the petals should close the opening perfectly (left side on the photo). In the right side of the photo, you can see deformed petals that remain slightly raised.

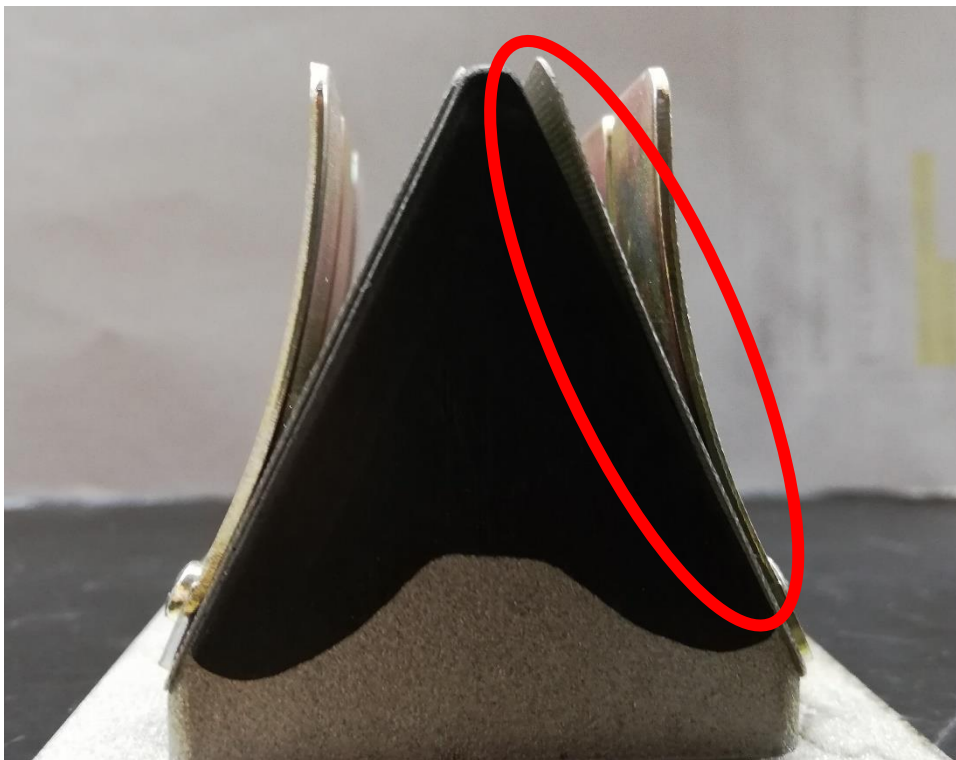

If the previous checks are not passed or if routine maintenance is required, replace the petals.

3.5.3 Reed valve assembly

Replace the petals (11) and place them against the bearing surface (12).
Position the stoppers (10).
Insert the 3 Phillips screws M3x6 (9).



Check that the petals rest perfectly on the surface of the reed valve (see previous photo).
Please note: the two chamfers on the stopper and on the petals (blue circles) may not match.

Carry out the same operations on the other side of the reed valve.

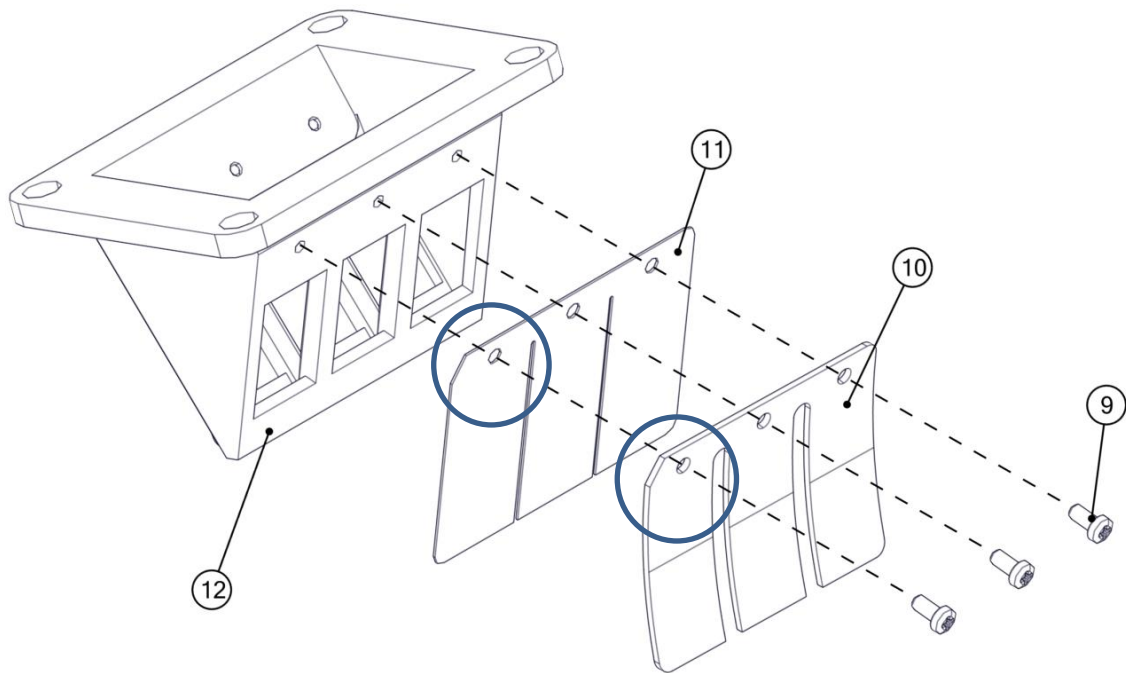

Replace the gaskets (3, 7) each time they are disassembled.

Place the reed valve (6) with the reed valve gasket (7) on the crankcase (8).
Insert the flow guide (5) with the O-ring (4) and the flange gasket (3) on the reed valve (8).
Insert the carburettor flange (2).
Insert the 4 Allen screws M6x30 (1) into the carburettor flange (2), tighten progressively, then tighten with the torque shown in the figure.

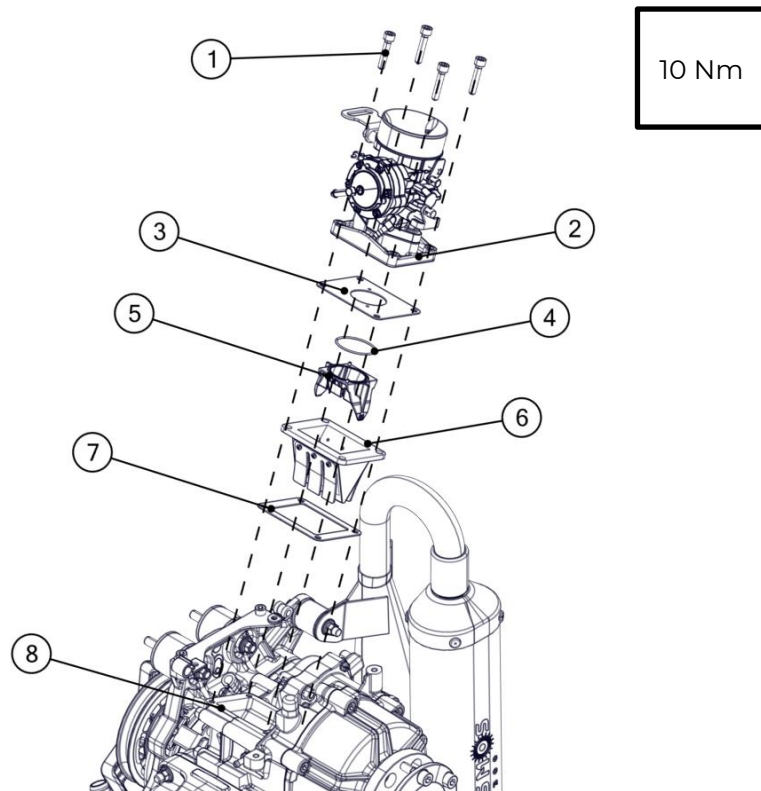

Connect the pulse line hose to the carburettor and secure it with the double wire hose clamp.

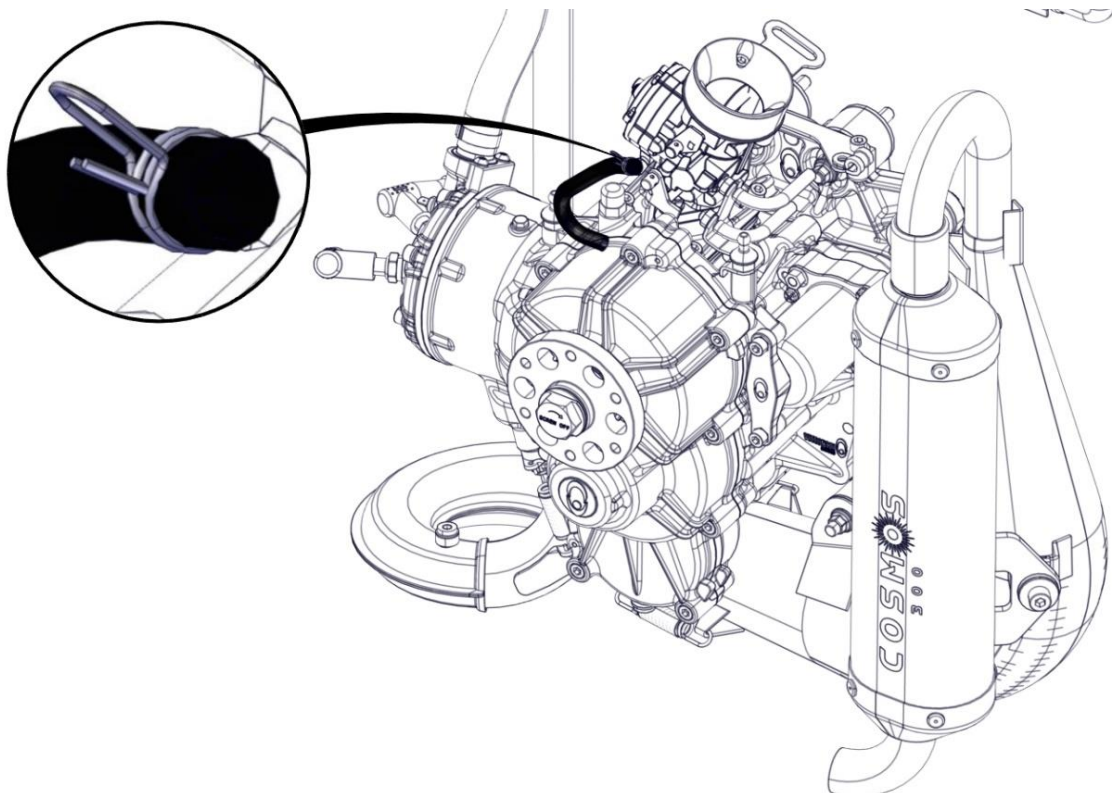

3.6 Gaskets





Always replace the gaskets when removing components in contact with them or in the event of leakage. Also, if the engine is not used for a long period of time, check the condition of the gaskets.



For gasket replacement see the following chapters: 3.4 Carburettor, 3.5 Reed valve, 3.7 Exhaust system, 3.13 Transmission, 3.14 Piston, cylinder, head.

3.7 Exhaust system

 Components to replace		Time limit
	Kit exhaust bushing (C202)	50 h
	Gasket* (C137)	50 h
	Self-locking nuts M8* (M019)	50 h
	Exhaust manifold (C200a)	200 h
	Springs (M139, MP140, MP141)	200 h
	Silencer rubber (C140)	150 h or 1 year
	Sound soundproofing material (C159)	100 h
	Silencer (C160)	on condition
	Silicone HT Sil-N*	100 h
Molykote grease*	50 h	
 Special tools	Not required.	
 Values	Self-locking nuts M8: 32 Nm. Screws M8: 13 Nm.	

*Always replace it when disassembled.

3.7.1 Manifold, exhaust bushing disassembly

Remove the safety cables around the springs.

Remove the 4 bushing springs and the 2 exhaust manifold springs.

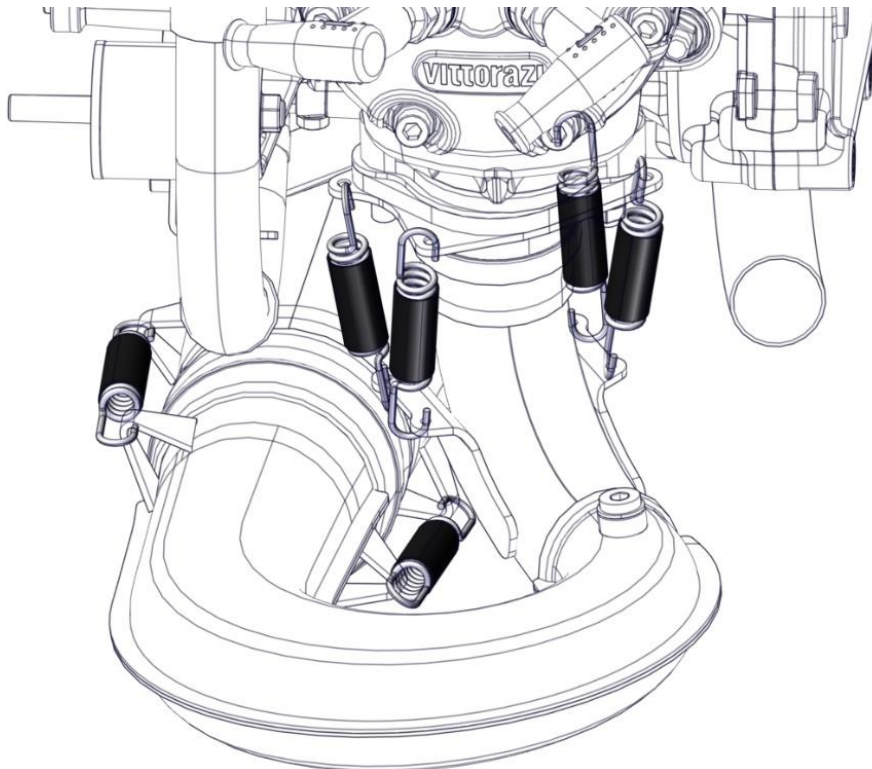

Remove the exhaust manifold (1), the 2 self-locking nuts M8 (2) with washers (3), the exhaust flange with bushing (4) and the gasket (5).

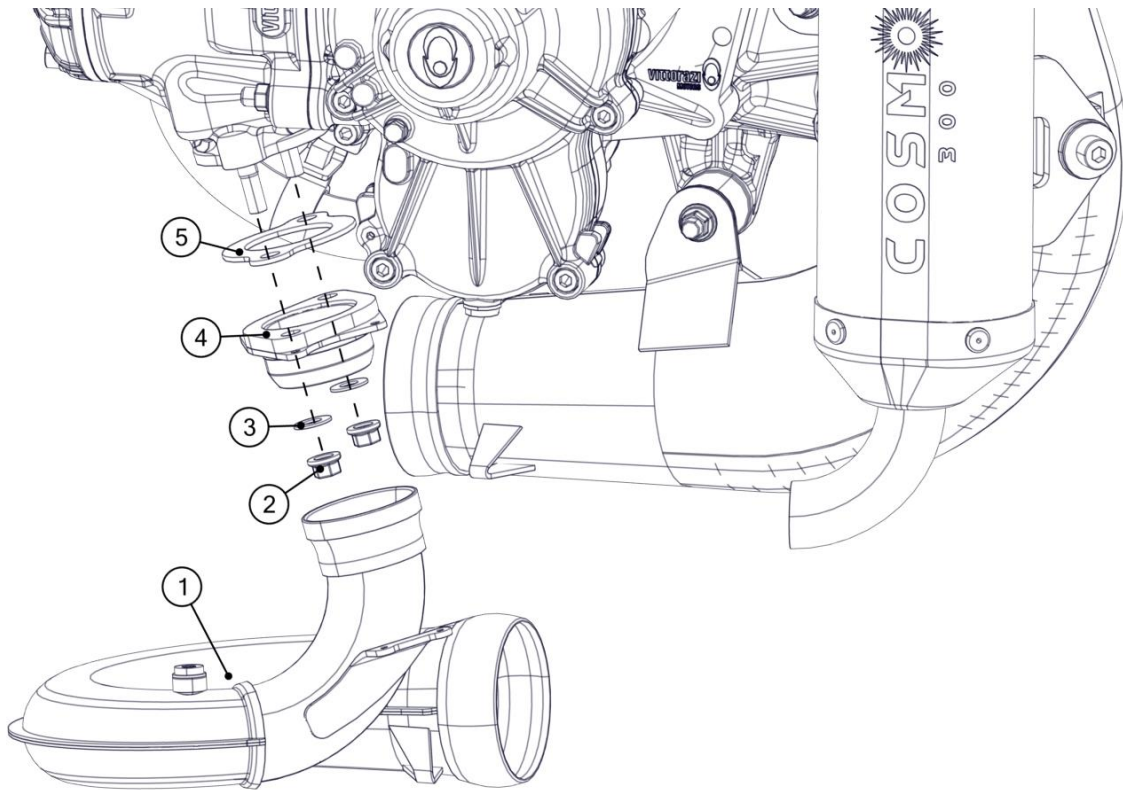

Remove the bronze ring (6) from the flange (4).

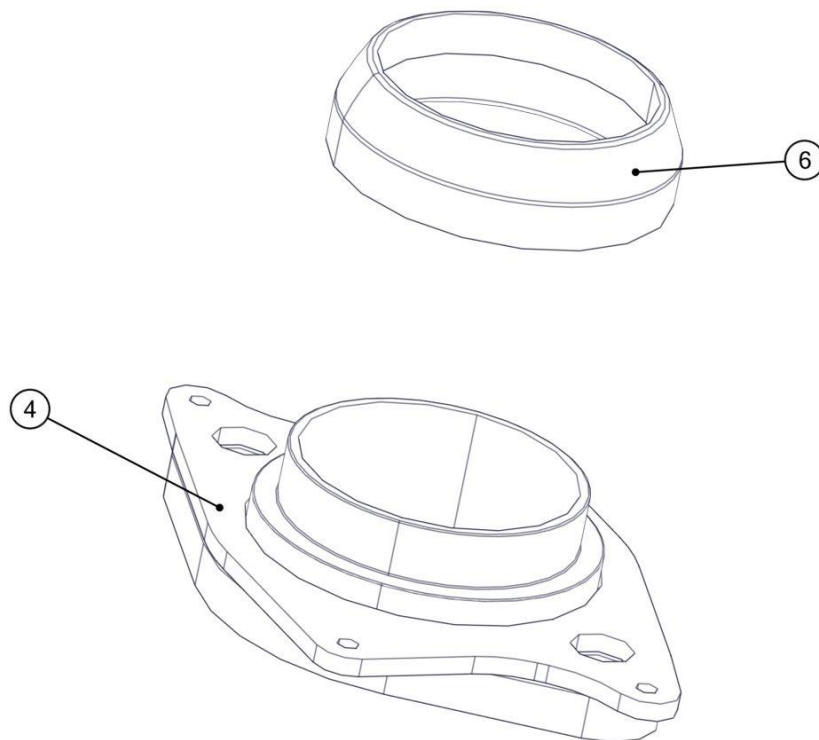

3.7.2 Manifold, exhaust bushing maintenance

Clean flange contact surface with the cylinder from any gasket or silicone residue, and check that it is flat.

Check the integrity of the exhaust manifold: there must be no cracks or damaged areas, otherwise it must be replaced. For routine maintenance, follow the table.

Check that the exhaust joints are regular. Small defects on the surface (sticking marks, cracks, steps) must not prevent a regular motion of the joint.



3.7.3 Manifold, exhaust bushing assembly

Replace the bronze ring (6) of the flange (4).



Check that the bronze ring (6) comes into contact with the seat of the bushing (4) to prevent leakage from the exhaust system.

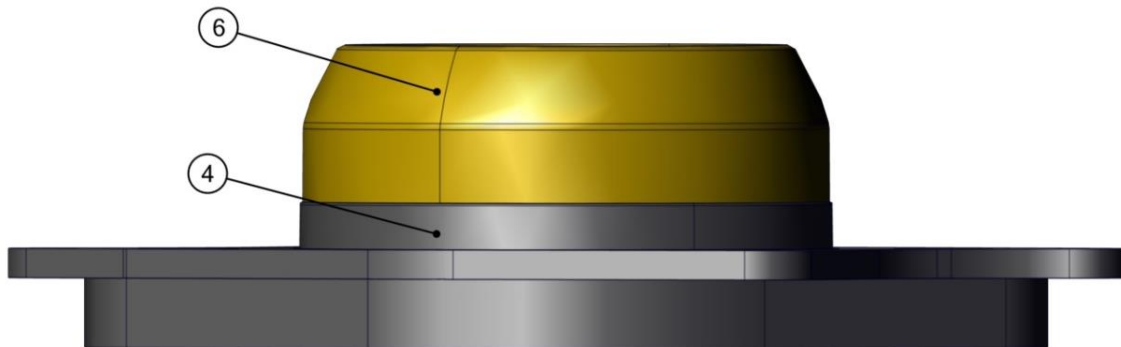

Clean the bushing and cylinder from gasket residue.

Clean the end of the exhaust manifold (7), sand it with sandpaper and apply Molykote grease.

Clean the second joint (8) with an abrasive sponge (e.g. Scotch-Brite), degrease it with solvent and apply Molykote grease.

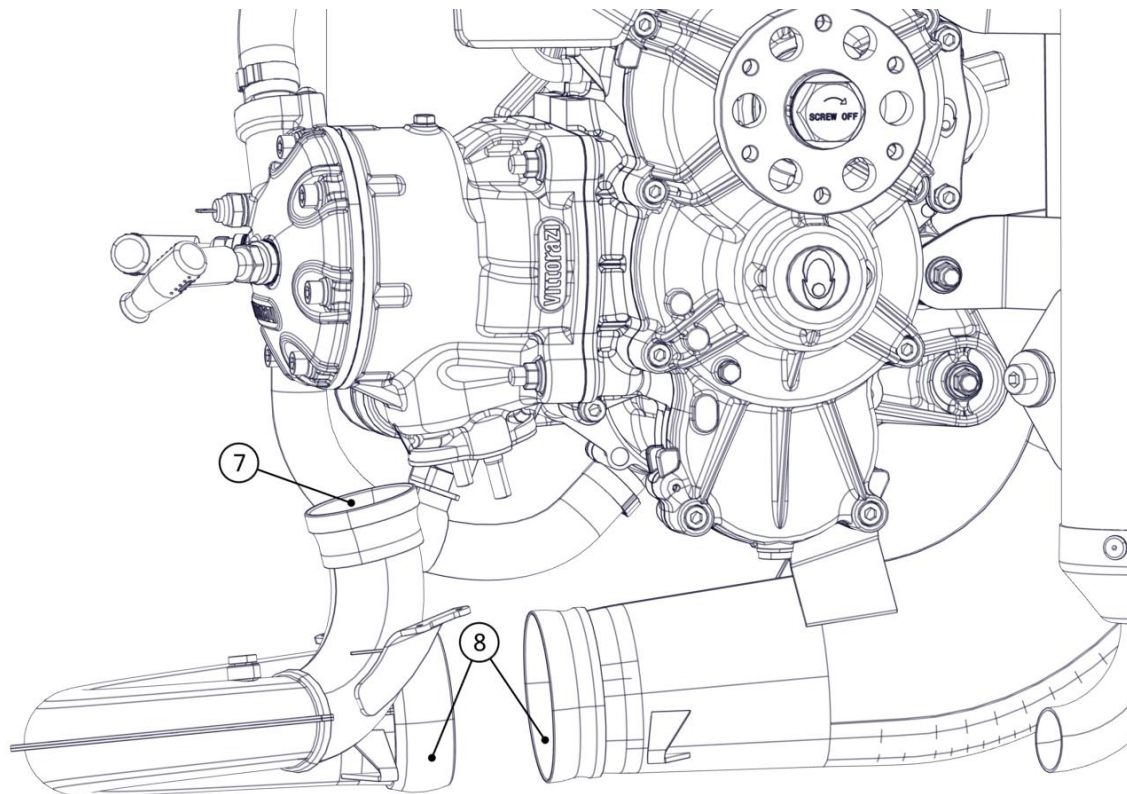



Replace the gasket (5), the 2 self-locking nuts M8 (2) and the 2 washers (3) each time they are disassembled.

Insert the gasket (5) and the flange (4).

Add copper paste to the nuts.

Insert the 2 self-locking nuts M8 (2) with the washers (3) and tighten with the torque shown in the figure.

Position the exhaust manifold (1).

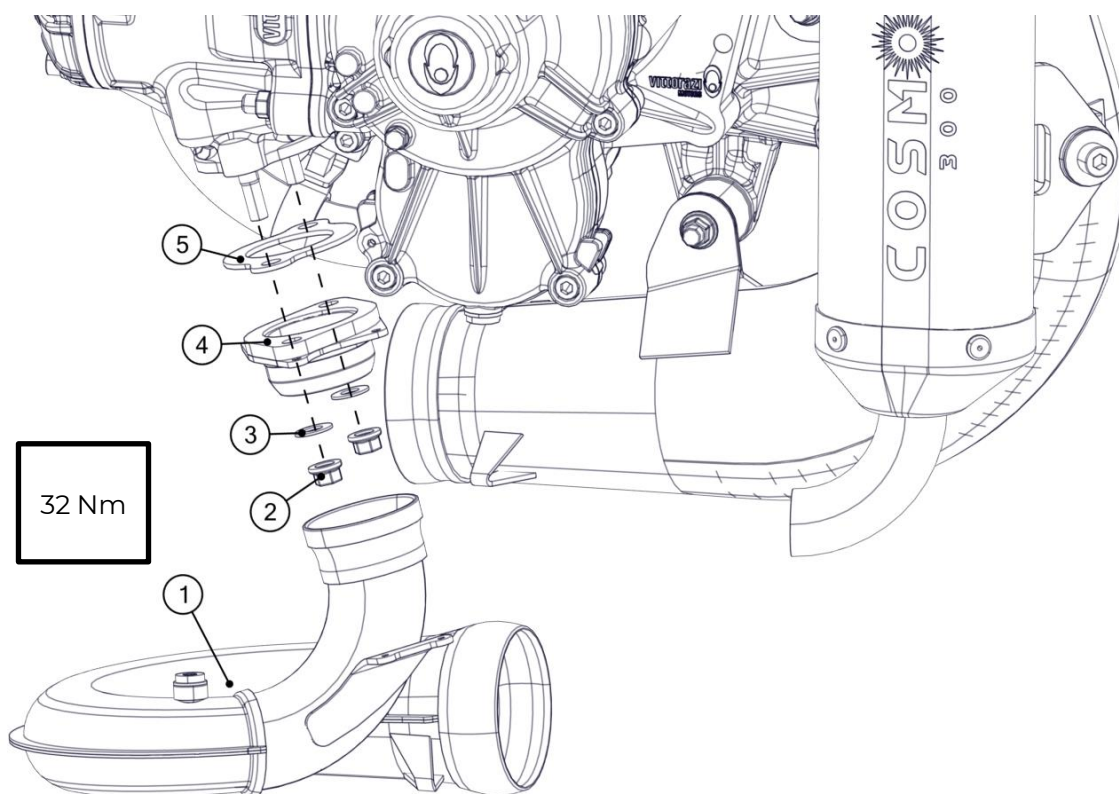

Hook the 2 springs onto the second joint.

Run 2 cables around the springs of the joint (one cable for each spring), insert a clamp on the ends and tighten with pliers.

Hook in the 4 springs of the bushing.

Run one cable around the 4 bush springs, insert a clamp at each end and tighten with pliers.

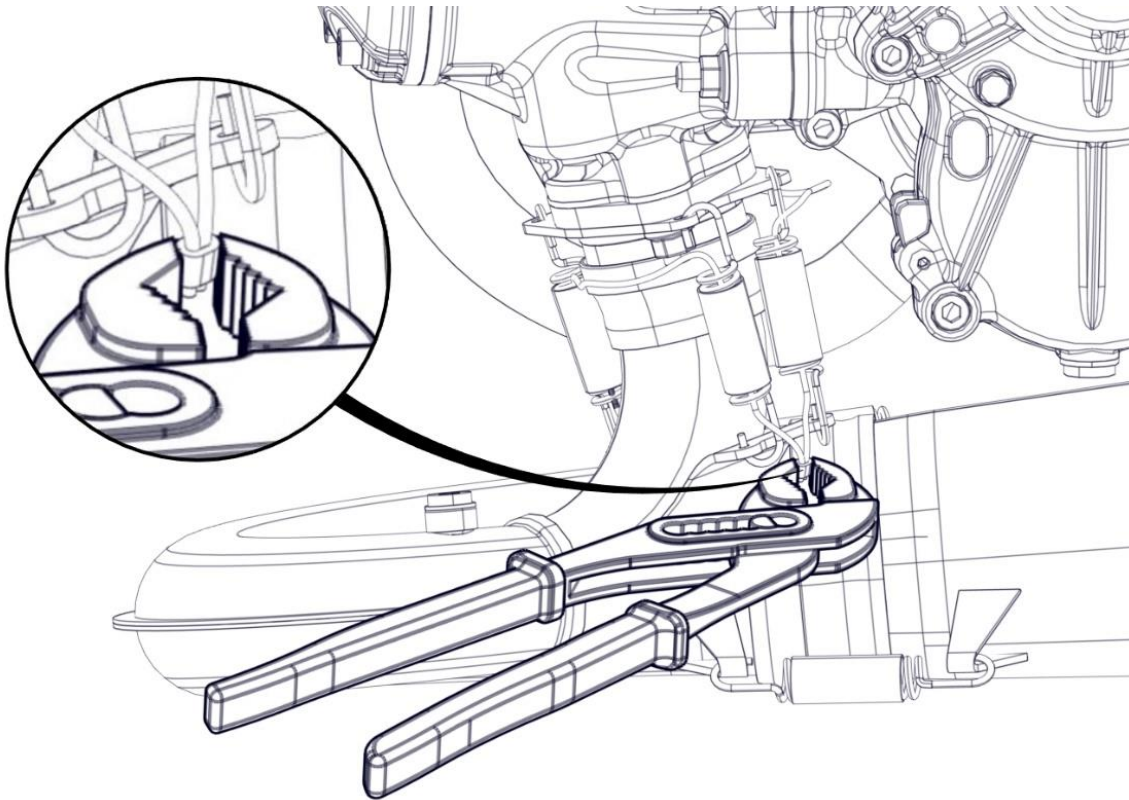

3.7.4 Silencer disassembly

Remove the 2 Allen screws M8 with washers, the 2 rubbers and the 2 bushings from the silencer.

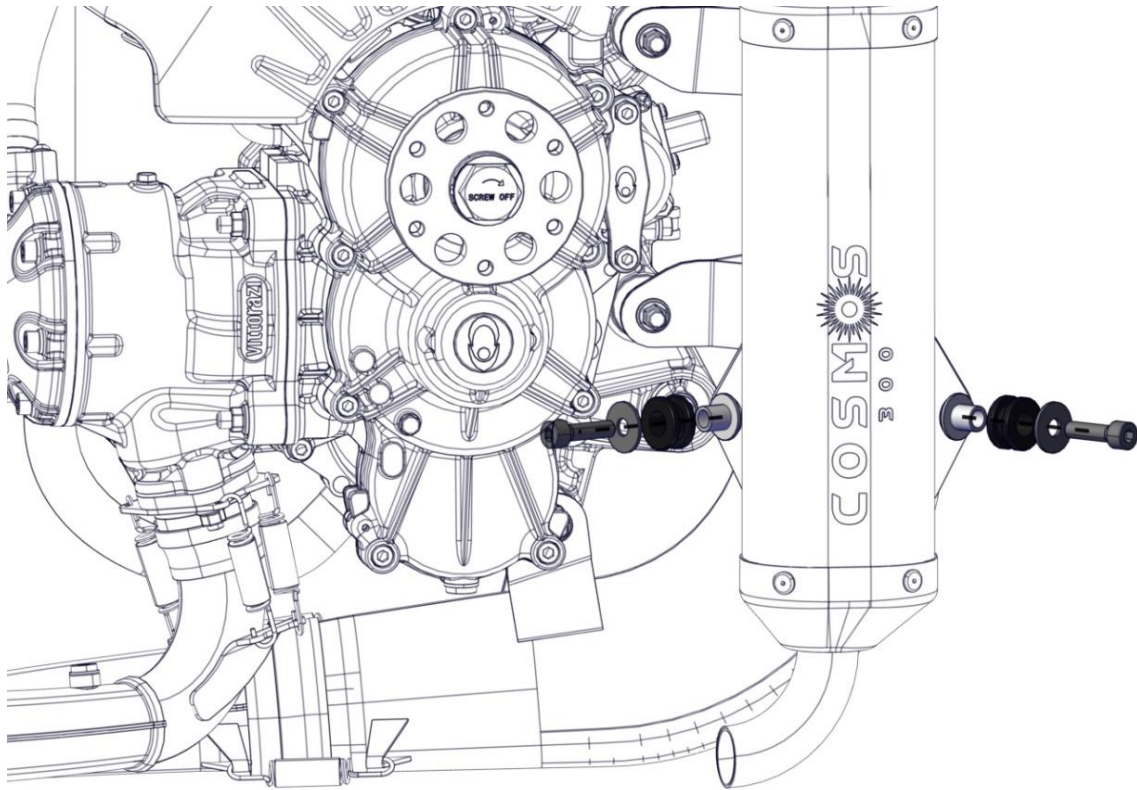

Disconnect the silencer from the exhaust pipe (In order to facilitate the release of the silicone heat with a heat gun, the connection between the exhaust and the silencer before disassembly).

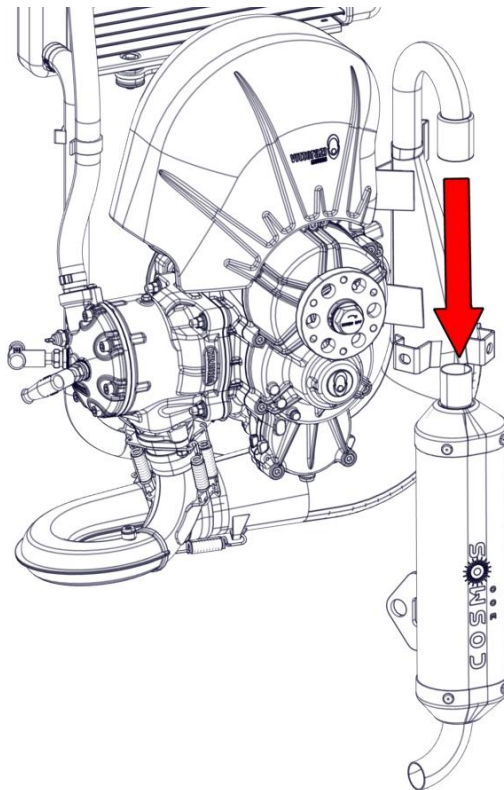



Before disassembling the silencer mark the position of the end caps with an erasable marker

Drill the 8 rivets centrally using a drill with a 5 mm diameter bit.

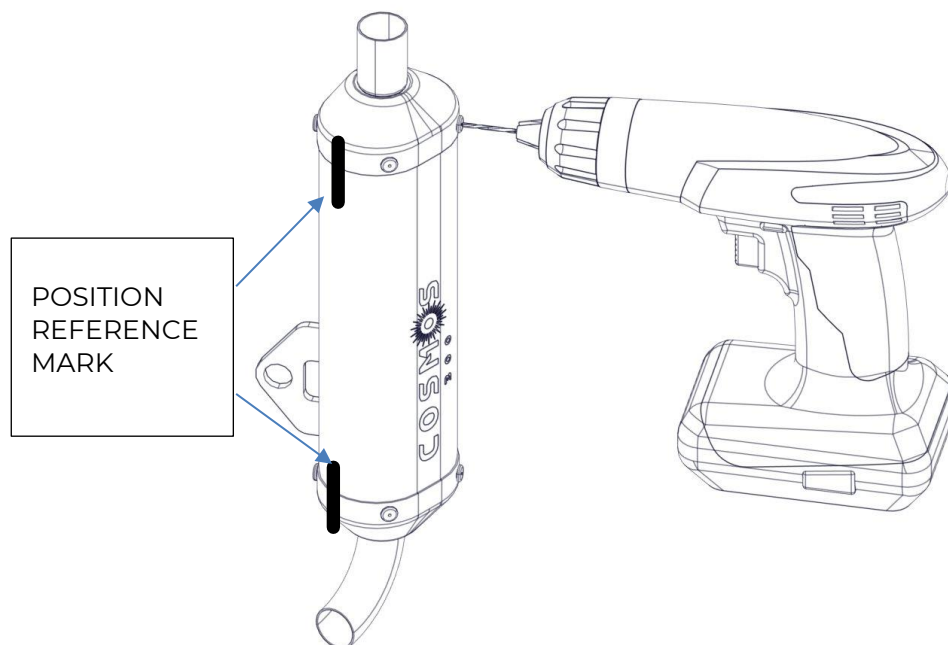

Use a heat gun to heat the muffler end caps (1, 4).
Remove the following components from the silencer housing (3): the end caps (1, 4) and the sound-absorbing material (2).

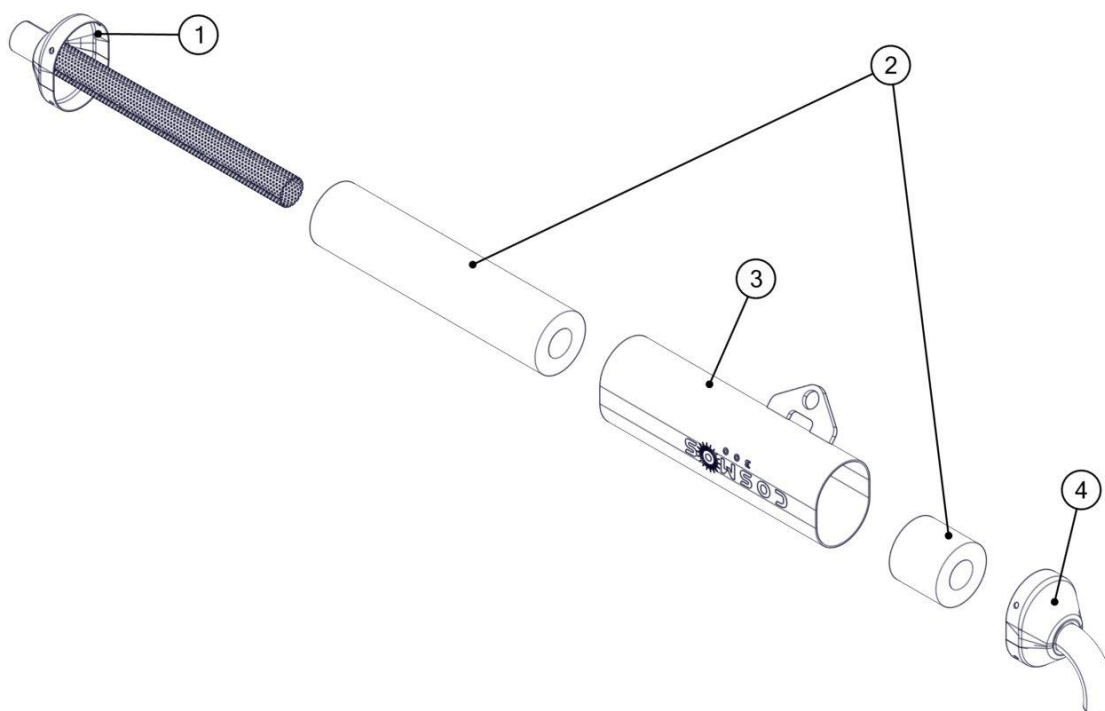

3.7.5 Silencer maintenance

Remove silicone residue from inside the silencer.

Thoroughly clean and degrease the end caps and body of the silencer with a cloth.

Check the integrity of the silencer body both internally and externally: there must be no cracks or damaged areas, otherwise replace it. For routine maintenance, follow the table.

3.7.6 Silencer assembly

Put high-temperature silicone (HT Sil-N) on the inside edge of the end caps (1, 4).

Wrap the sound-absorbing material (2) around the inner tube (1) and then position them in the silencer body (3).

Wrap the sound-absorbing material (2) on the end cap (4) then position them in the silencer body (3).

Fix the end caps on the body with 8 rivets respecting the references taken during disassembly. Make sure that the end caps are fully inserted before fixing.

Wet the rivets with high-temperature silicone (HT Sil-N) before fastening and fix the end caps (1, 4) on the body.

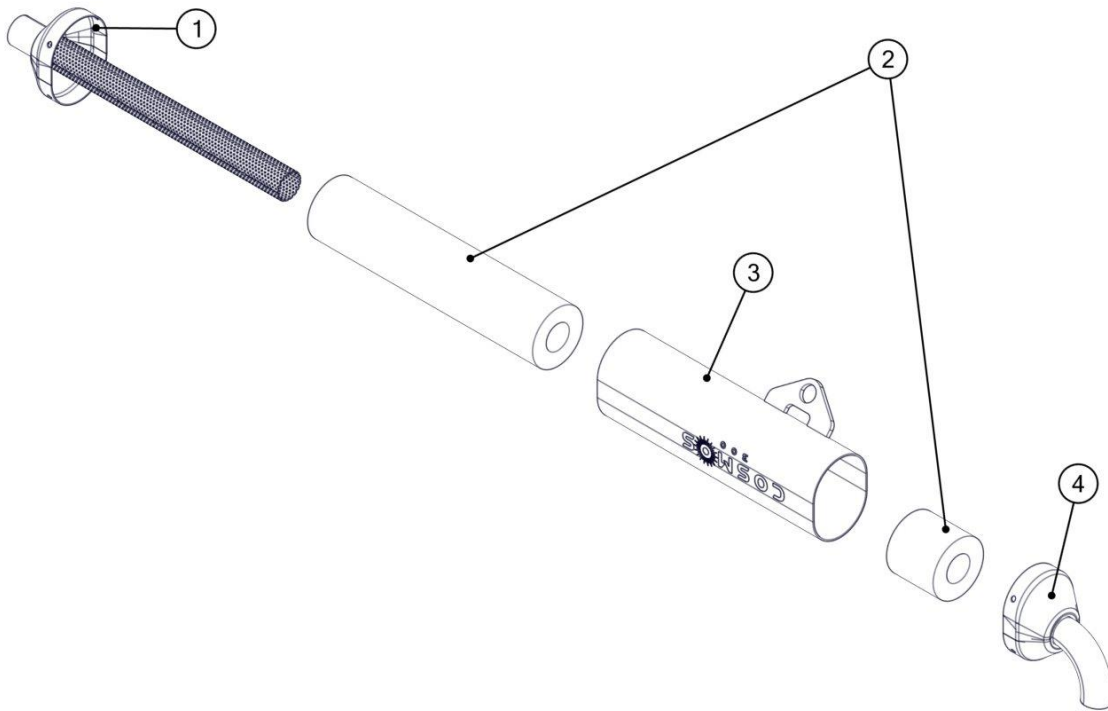

Position the rubber and the bushing into the silencer flanges.
Put silicone on the upper end of the silencer and connect it to the exhaust pipe.

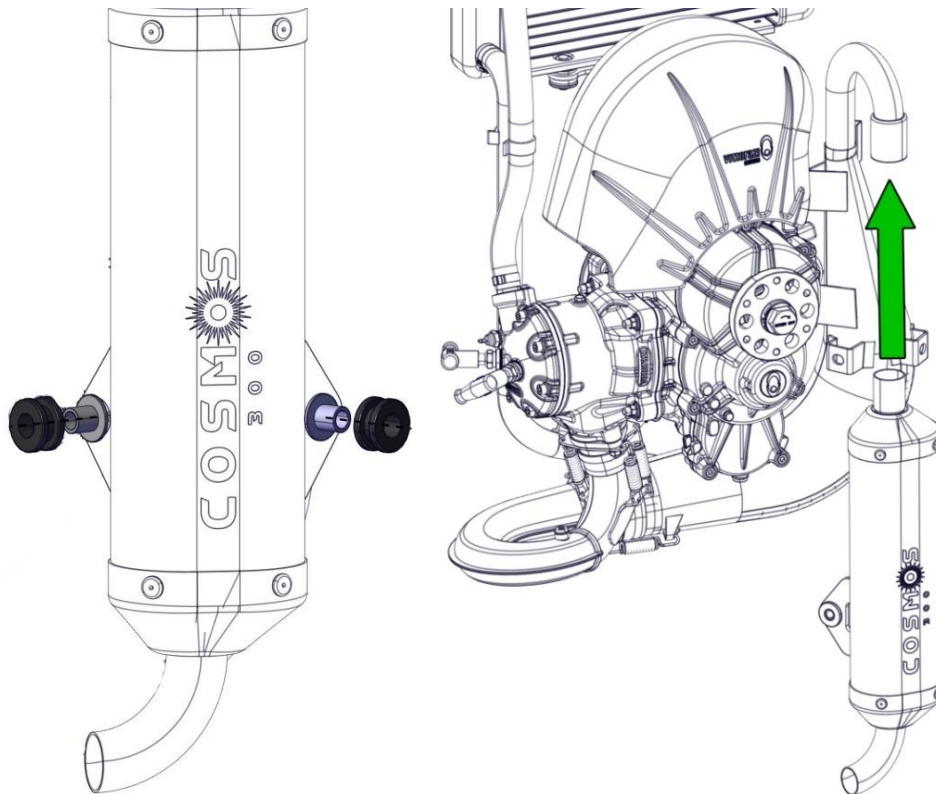

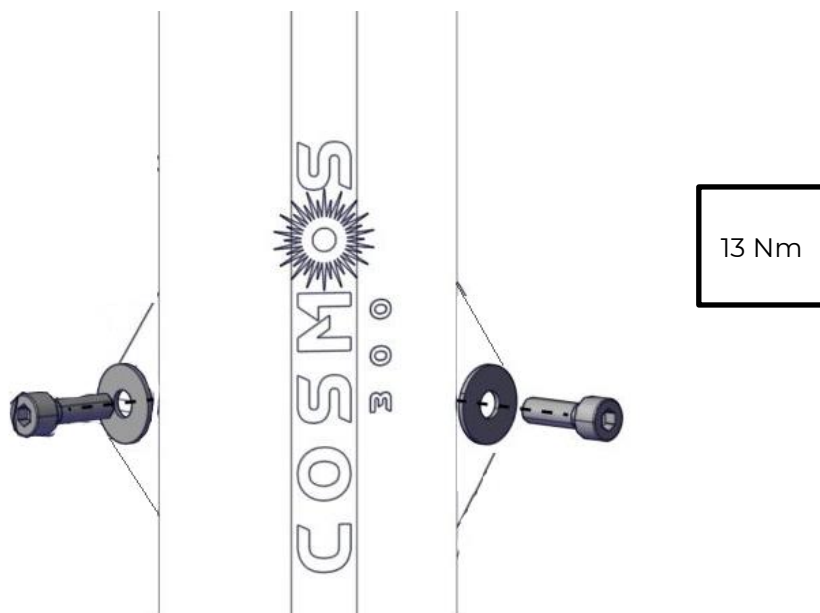

Replace the 2 rubbers on the silencer.

Insert the 2 bushings, 2 rubbers, 2 Allen screws M8 with washers and tighten with the torque shown in the figure.



3.8 Cooling system

 Components to replace		Time limit
	Copper seals* (AT162)	150 h or 1 year
	Radiator hoses (403, C407)	on condition
	Radiator rubbers (C404)	200 h or 2 years
	Coolant (ACC085)	150 h or 1 year
 Special tools	Not required.	
 Values	Screws M5x20: 8 Nm.	

*Always replace it when disassembled.

3.8.1 Cooling system emptying

Remove upper cap from the coolant reservoir.

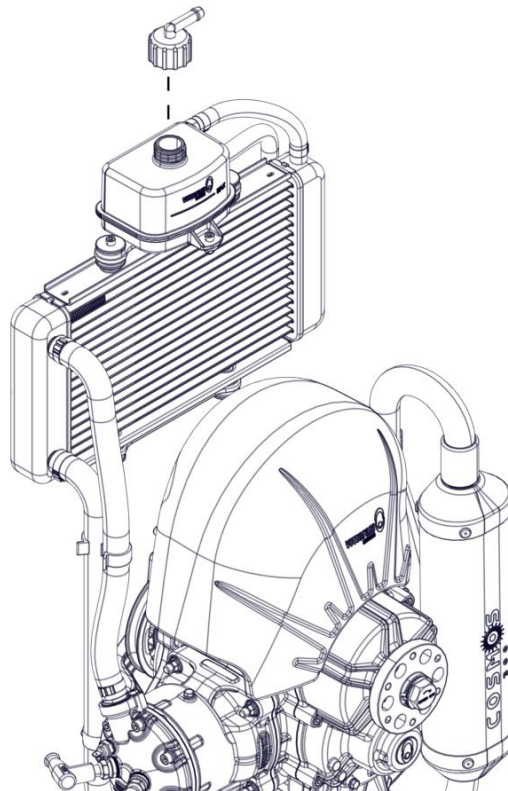

Place a container under the water pump cover to collect the coolant.
Remove the lower screw M5x10 with copper seal from the water pump cover.

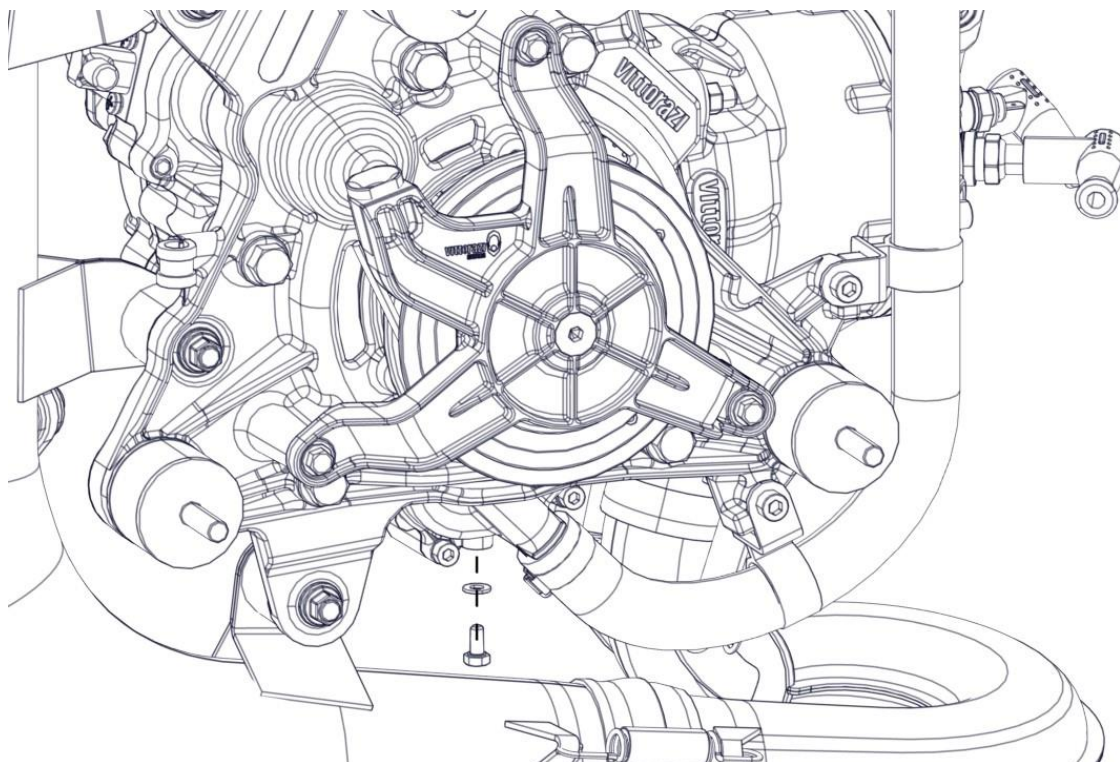

Wait a few minutes for all the coolant to escape.
For optimal cleaning, remove the clamp and disconnect the lower hose.

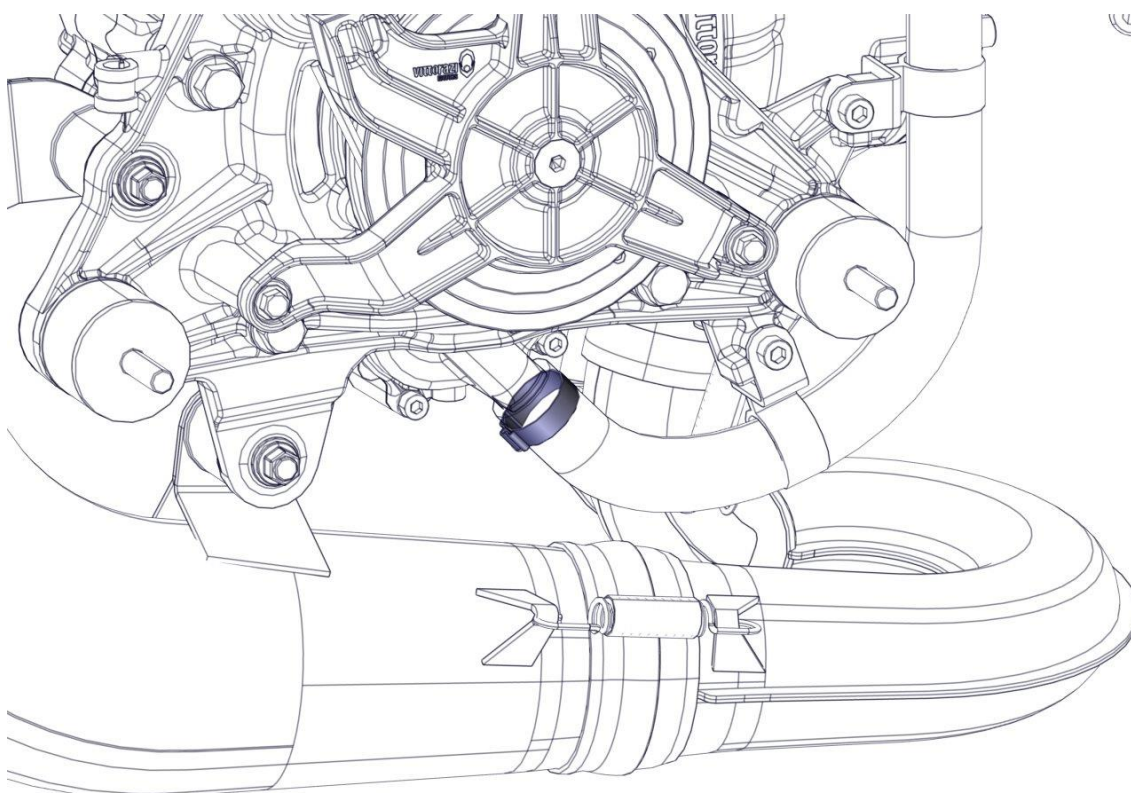

Wait a few minutes for all the coolant to escape.



Replace the clamp each time it is disassembled.
Connect the lower pipe, tighten the clamp with suitable pliers and ensure that the connection is secure.

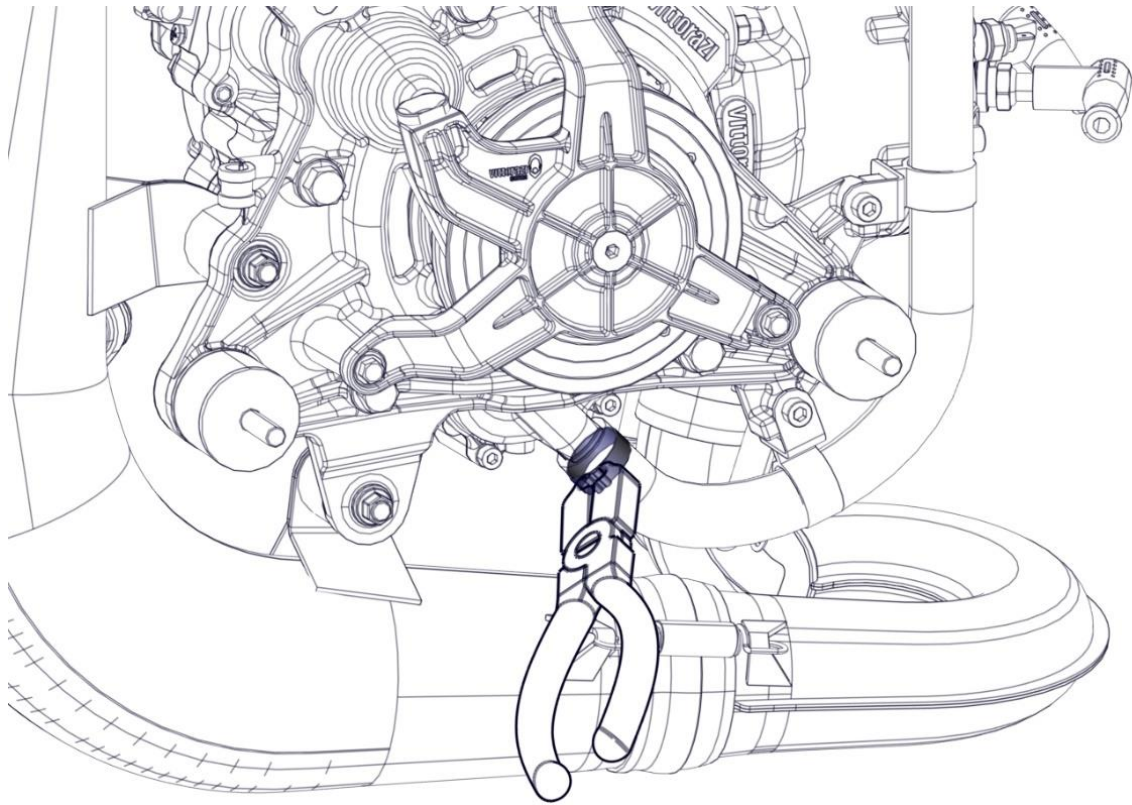

Replace the copper seal each time it is disassembled.

Insert the lower screw M5x10 with copper seal into the water pump cover and tighten with the torque shown in the figure.

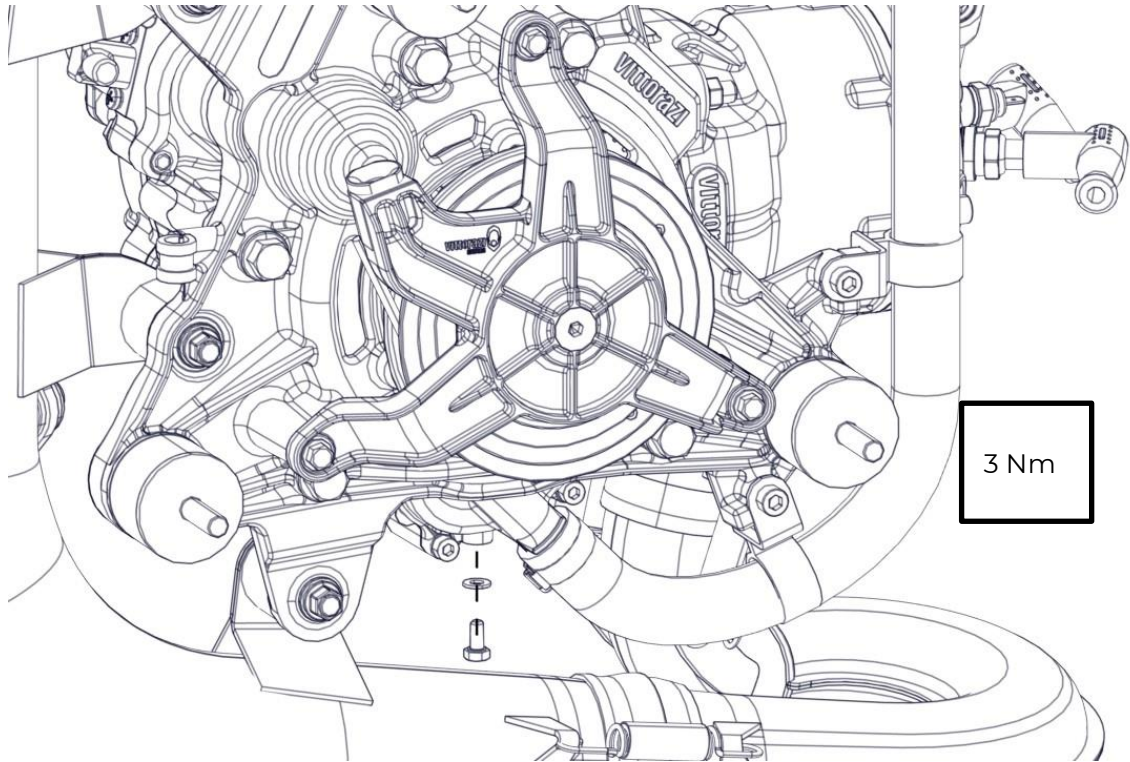

3.8.2 Cooling system filling



Insert the coolant (to be diluted with water according to the instructions on the packaging, the coolant must be suitable for use with aluminum components and the operating temperature must be between $-20\text{ }^{\circ}\text{C}$ and $110\text{ }^{\circ}\text{C}$) into the coolant reservoir up to the maximum level.

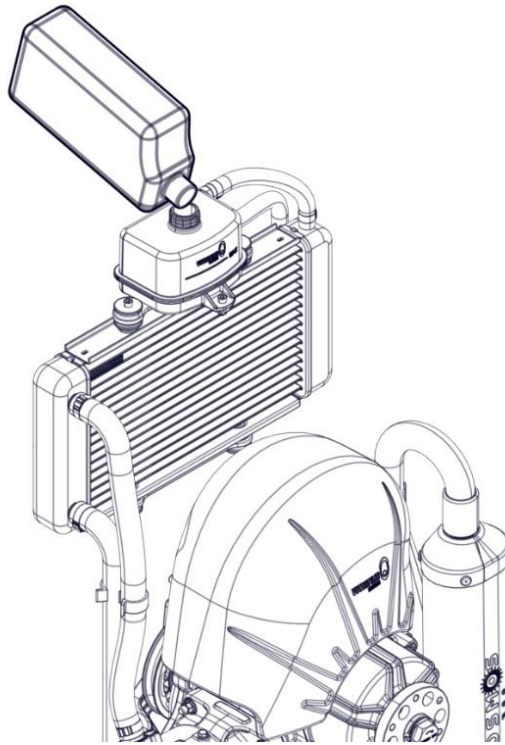

Remove vent screw M5x10 with copper seal from the cylinder to allow any air to escape.

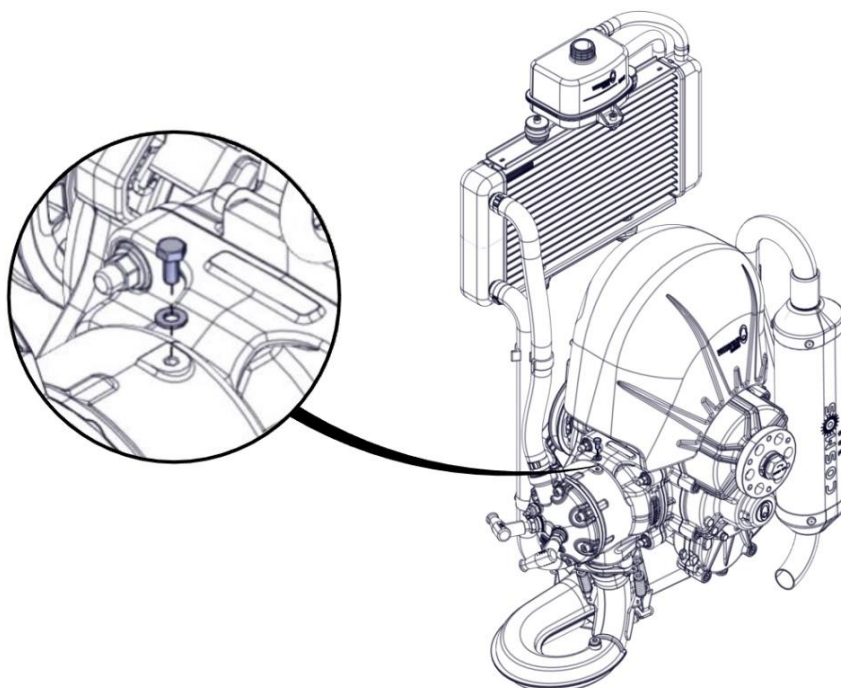



Replace the copper seal each time it is disassembled.

When a few drops of coolant escape, close with the vent screw M5x10, copper seal and tighten with the torque shown in the figure.

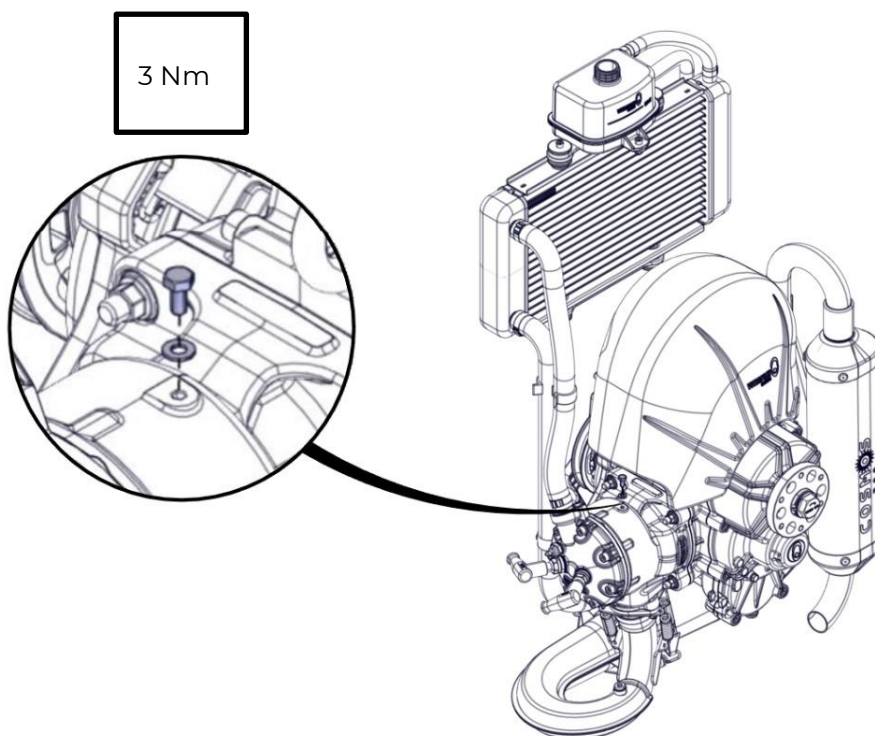

Fill the coolant reservoir again with coolant up to the maximum level.

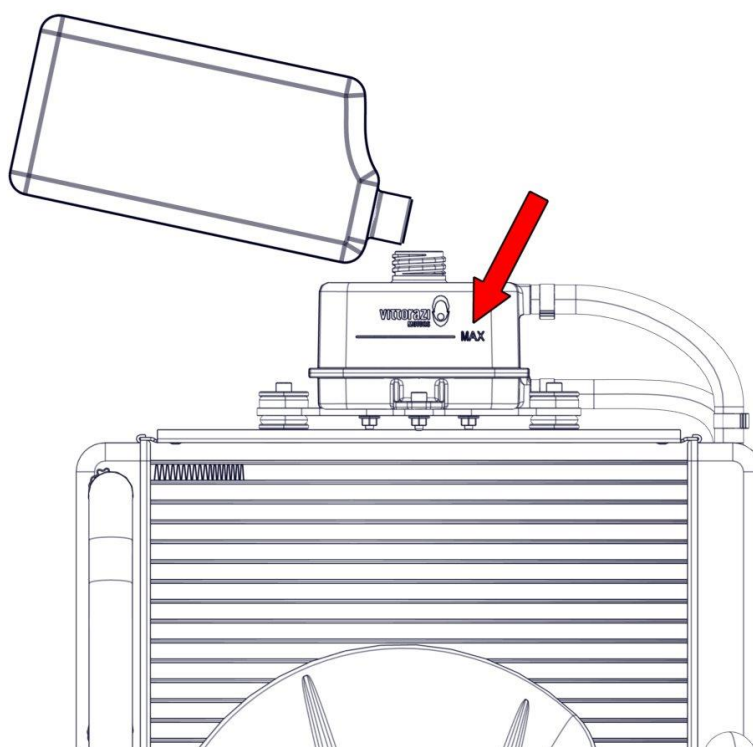

With the coolant reservoir uncapped, start the engine and keep it at idle (the vibrations produced will help any air remaining in the circuit to escape).
Turn off the engine.
If the coolant level has dropped add more coolant up to the maximum level.
Screw upper cap on the coolant reservoir.

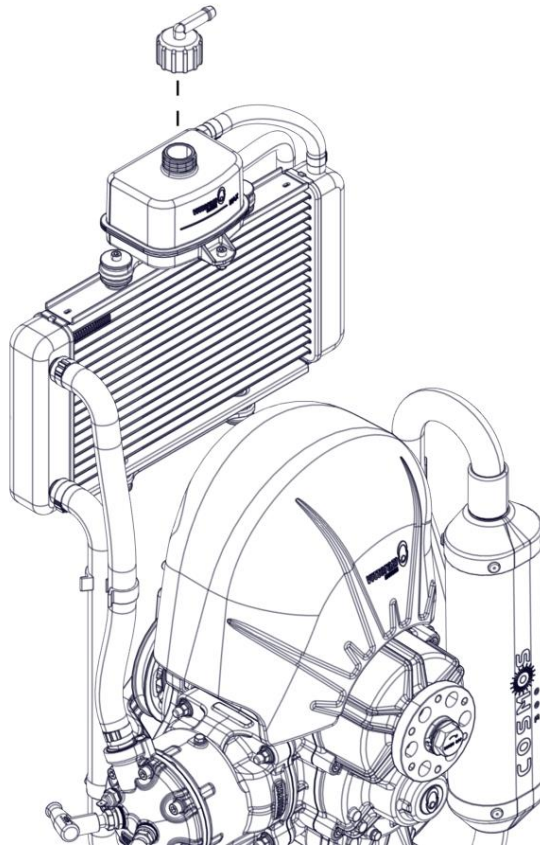

Never start the engine without propeller.

3.8.3 Radiator rubbers disassembly



Before disassembly empty the cooling system. Check chapter 3.8.1

Remove the 2 clamps from the coolant tray hoses.
Remove the 2 hoses.

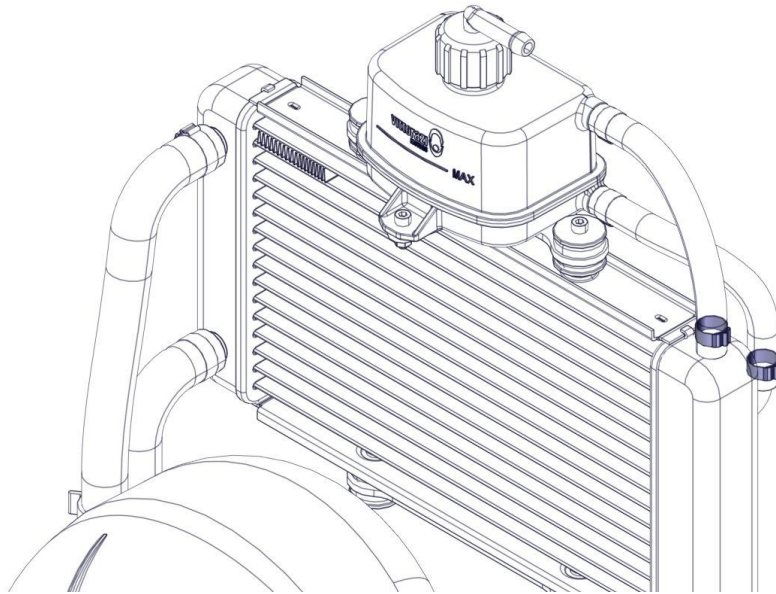

Remove the 2 Allen screws M5x20 (1) with the 2 washers 5x28x2,5 (2).
Remove the 2 rubbers (3), the upper bracket (4) and the 2 washers 10x28x2,5 (5).

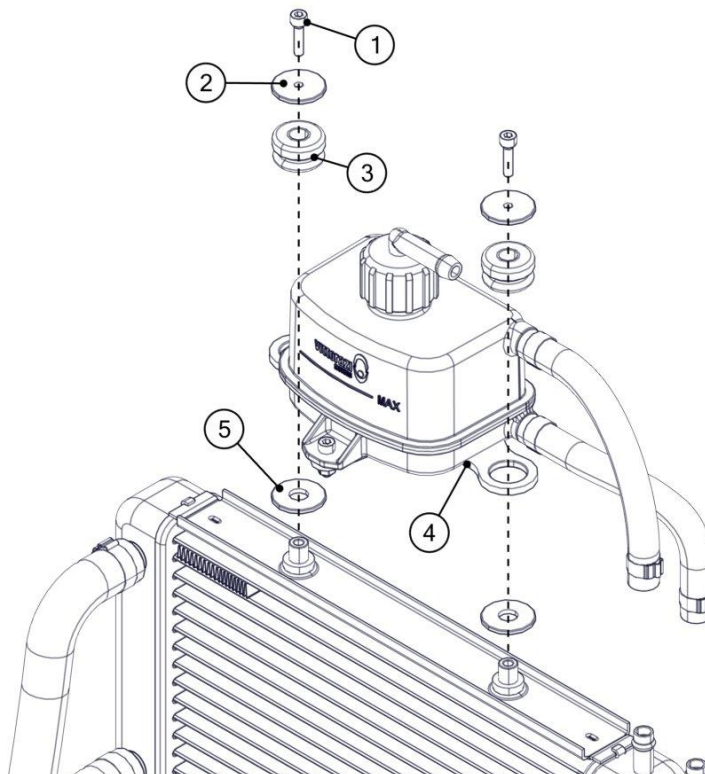

Remove the 2 Allen screws M5x16 (6) with the 2 washers 5x28x2,5 (7).
Remove the 2 rubbers (8), the lower bracket (9) and the 2 washers 10x28x2,5 (10).

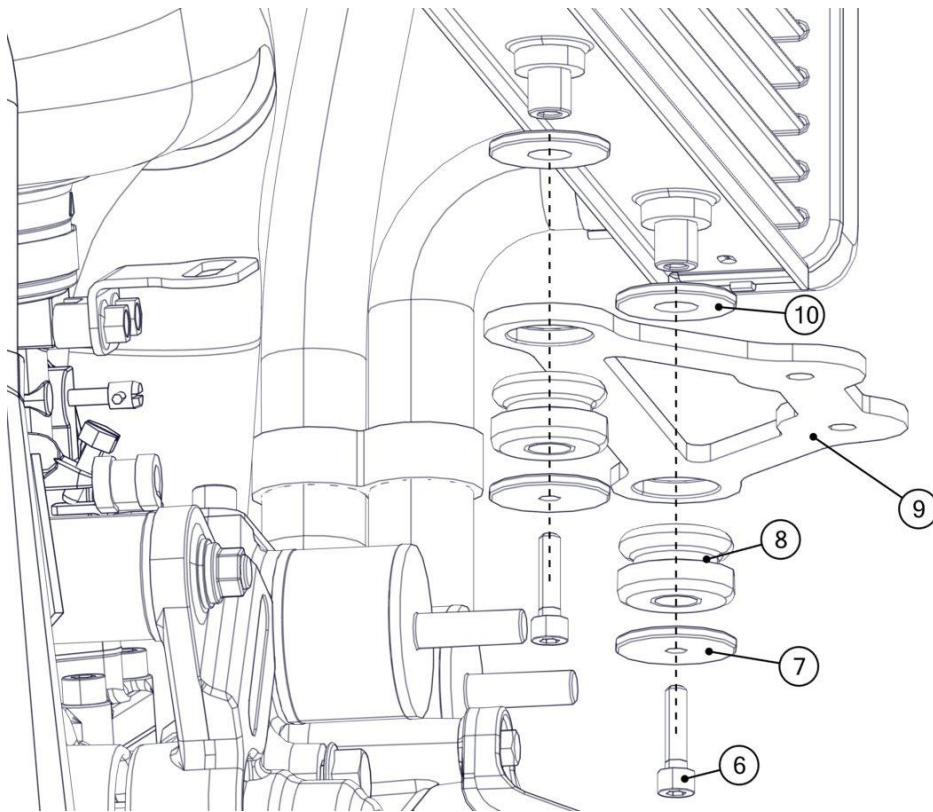

3.8.4 Radiator rubbers assembly

Insert the 2 rubbers (8) on the lower bracket (9).

Insert the 2 washers 10x28x2,5 (10) between the rubbers and the radiator.

Insert the 2 Allen screws M5x16 (6) with the 2 washers 5x28x2,5 (7) and tighten with the torque shown in the figure.

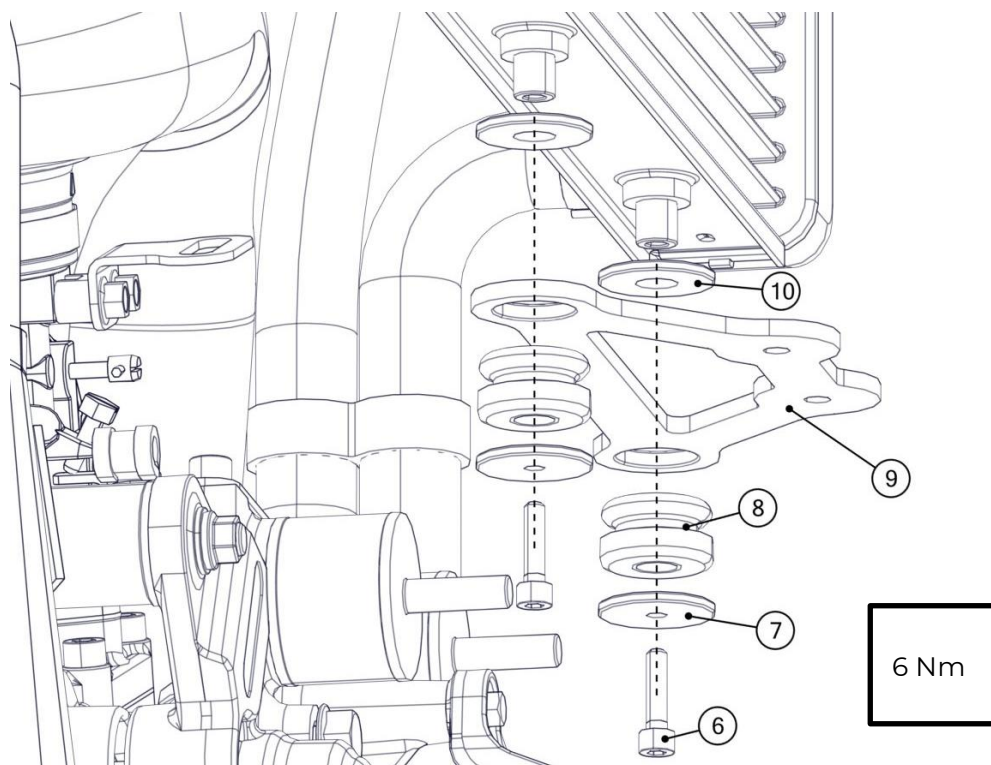

Insert the 2 rubbers (3) on the upper bracket (4).

Insert the 2 washers 10x28x2,5 (5) between the rubbers and the radiator.

Insert the 2 Allen screws M5x20 (1) with the 2 washers 5x28x2,5 (2) and tighten with the torque shown in the figure.

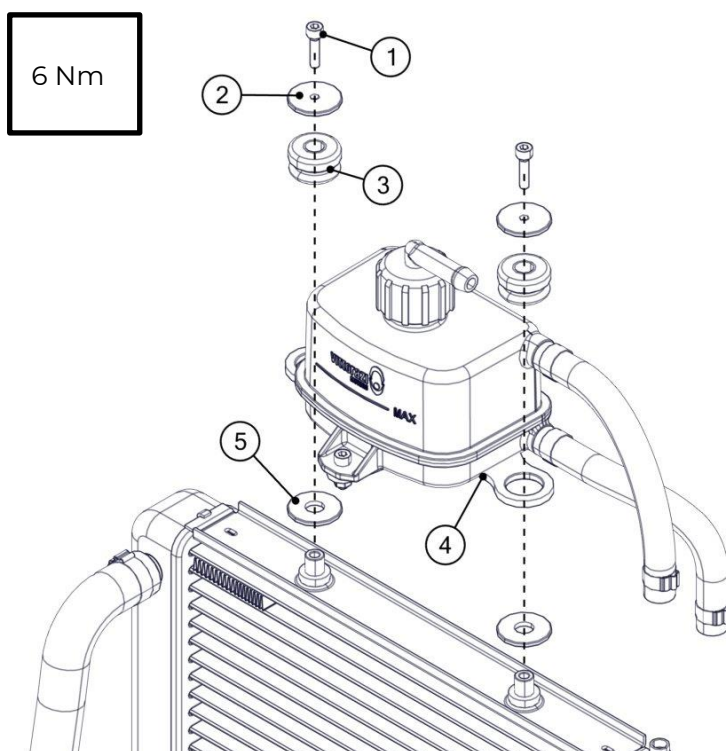



Replace the clamps each time they are disassembled.
Connect the 2 hoses to the radiator, tighten the clamps with suitable pliers and ensure that the connection is secure.

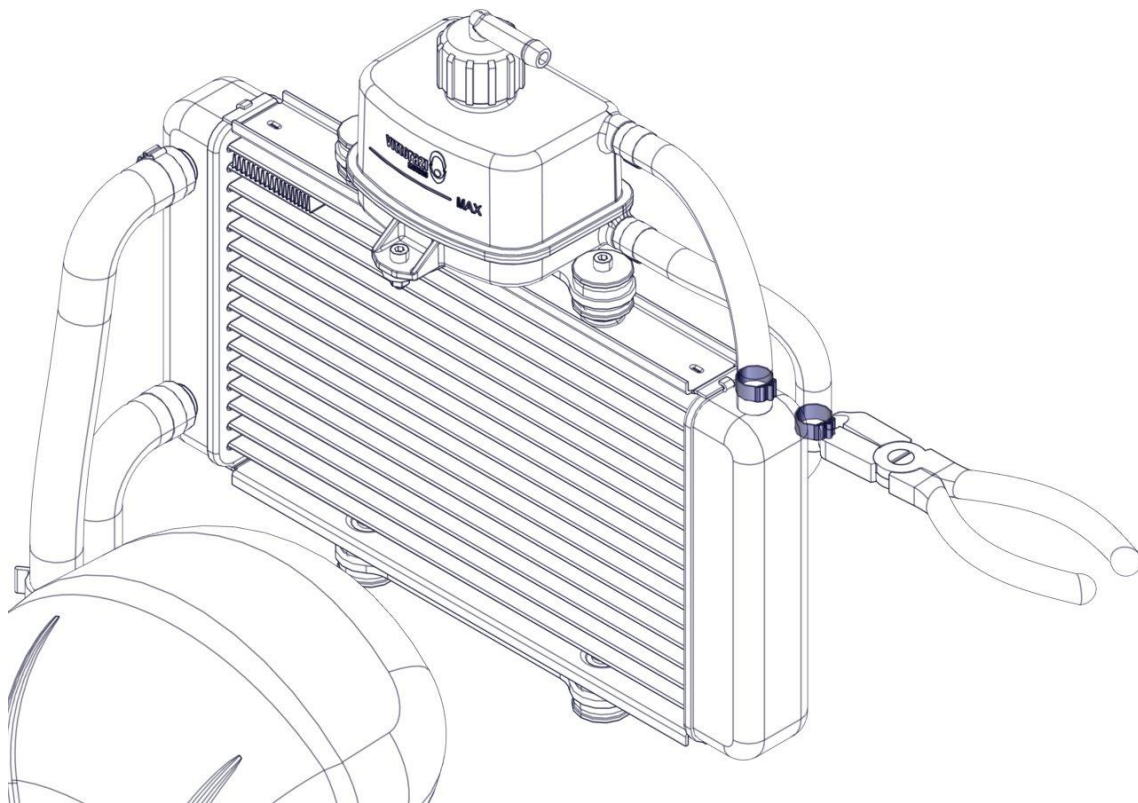

3.8.5 Cooling system maintenance

Check the 4 radiator hoses: there must be no cracks or damaged areas, otherwise replace them together with the clamps. For routine maintenance, follow the table.



Check the integrity of the coolant reservoir. If there is any damage replace it

Clean that interior of the coolant reservoir, from any deposit or dirt.



Do not clean the radiator with pressure washer.

3.9 Rubber mountings

 Components to replace		Time limit
	Engine rubber mountings (C021, C021f)	150 h or 1 year
	Exhaust system rubber mountings (C151)	150 h or 1 year
	Self-locking nuts M8* (M019)	150 h or 1 year
 Special tools	Not required.	
 Values	Self-locking nuts M8: 18 Nm.	

*Always replace it when disassembled.

3.9.1 Rubber mountings disassembly



When locking the rubber mountings during maintenance take care not to damage them.

Remove the safety cable around the springs.
 Remove the 4 bushing springs.

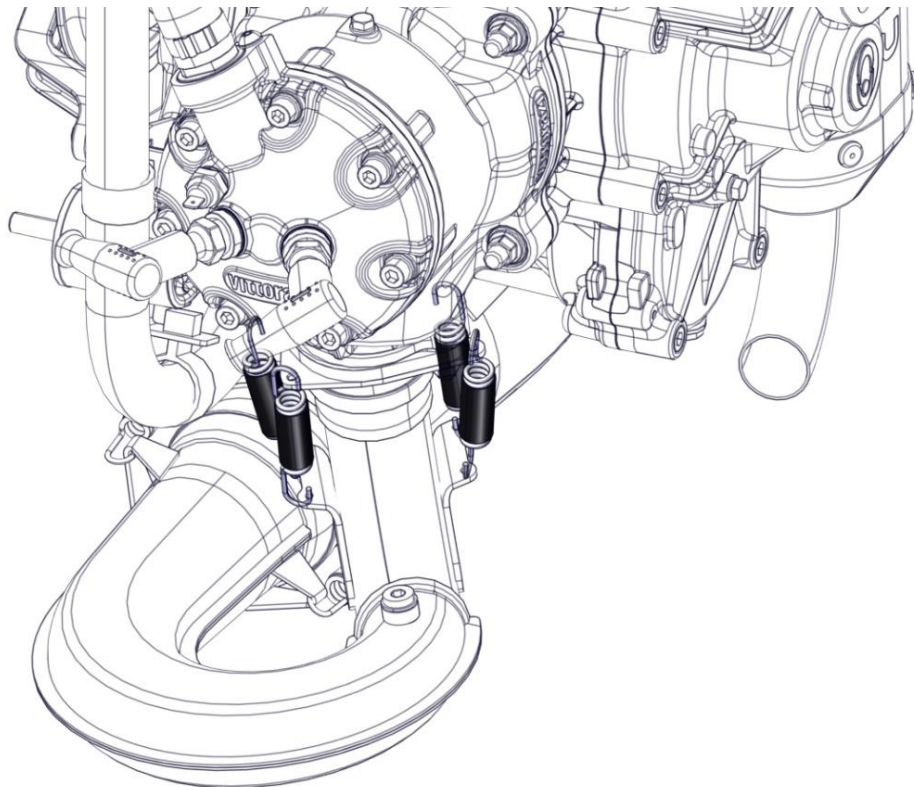

Remove the 3 self-locking nuts M8 with washers.

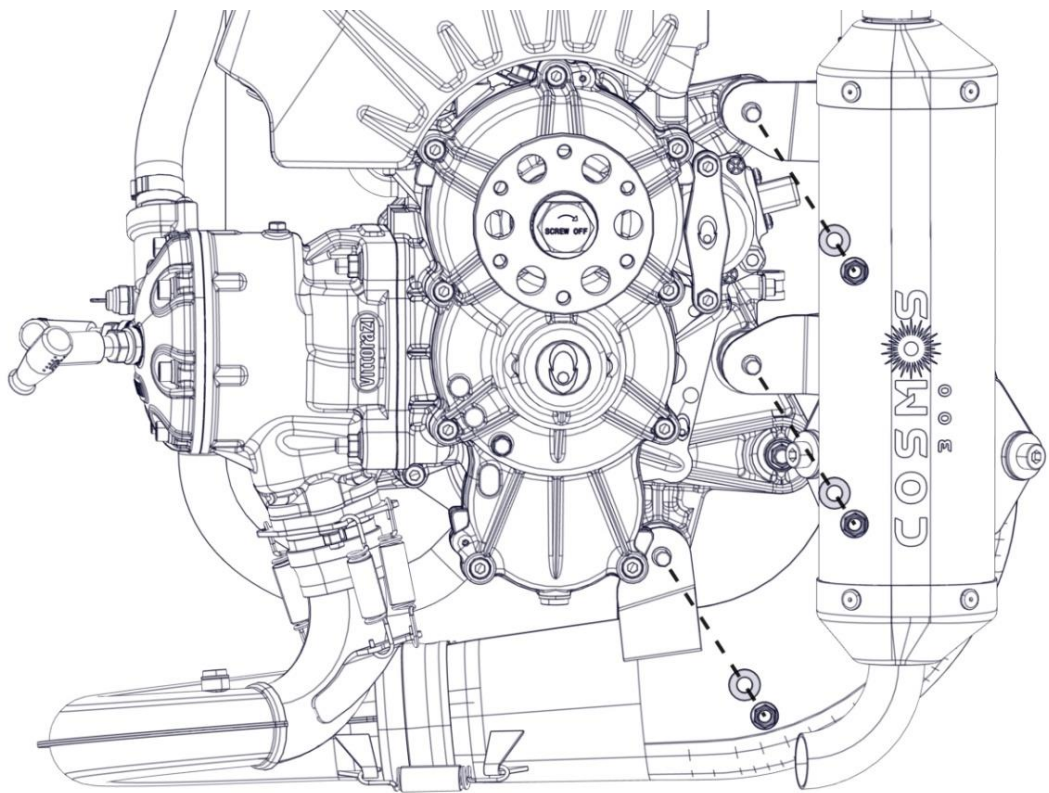

Remove the exhaust system.

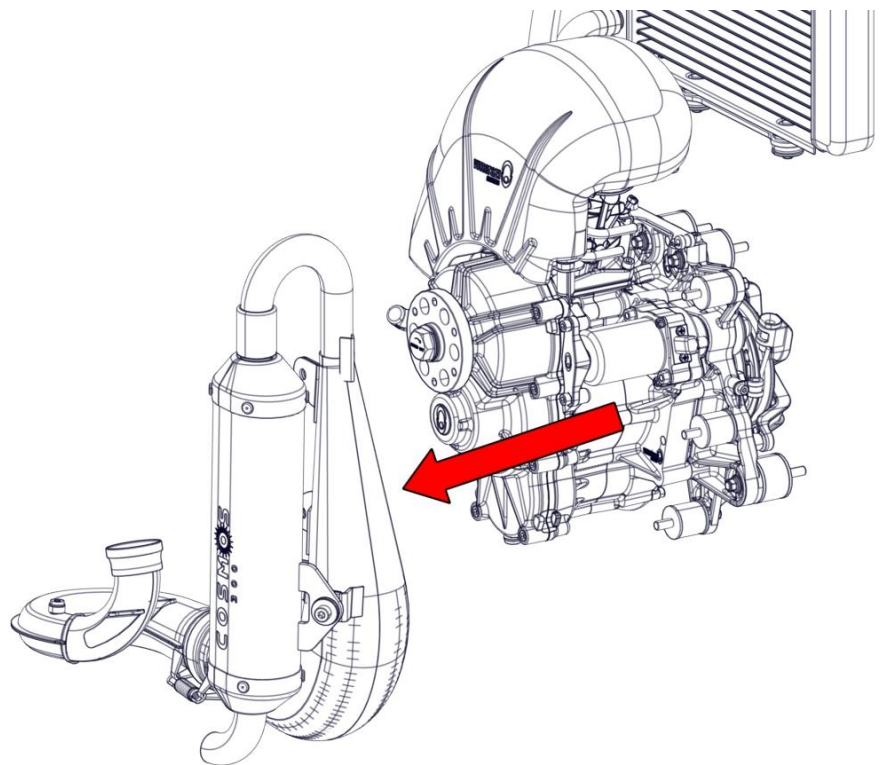

Remove the 4 self-locking nuts M8 with washers and the 4 rubber mountings from the motor mount.

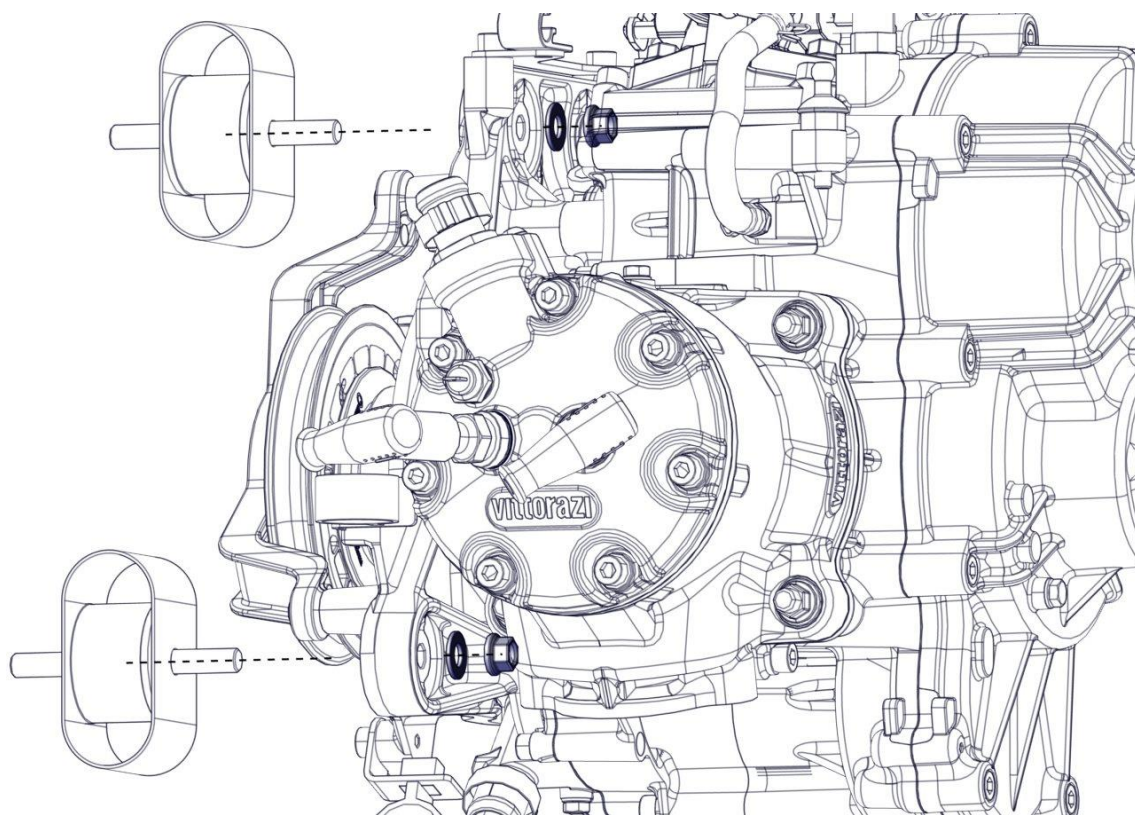
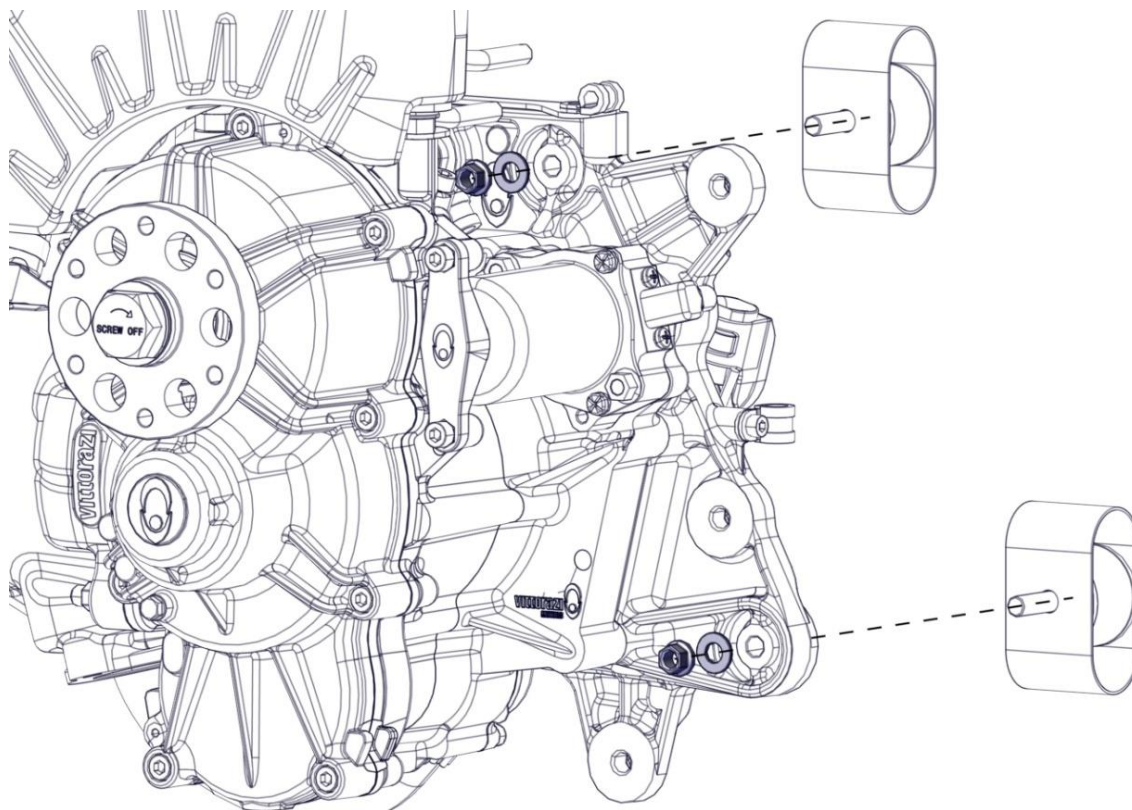

Remove the 3 self-locking nuts M8 with washers and the 3 rubber mountings of the exhaust system.

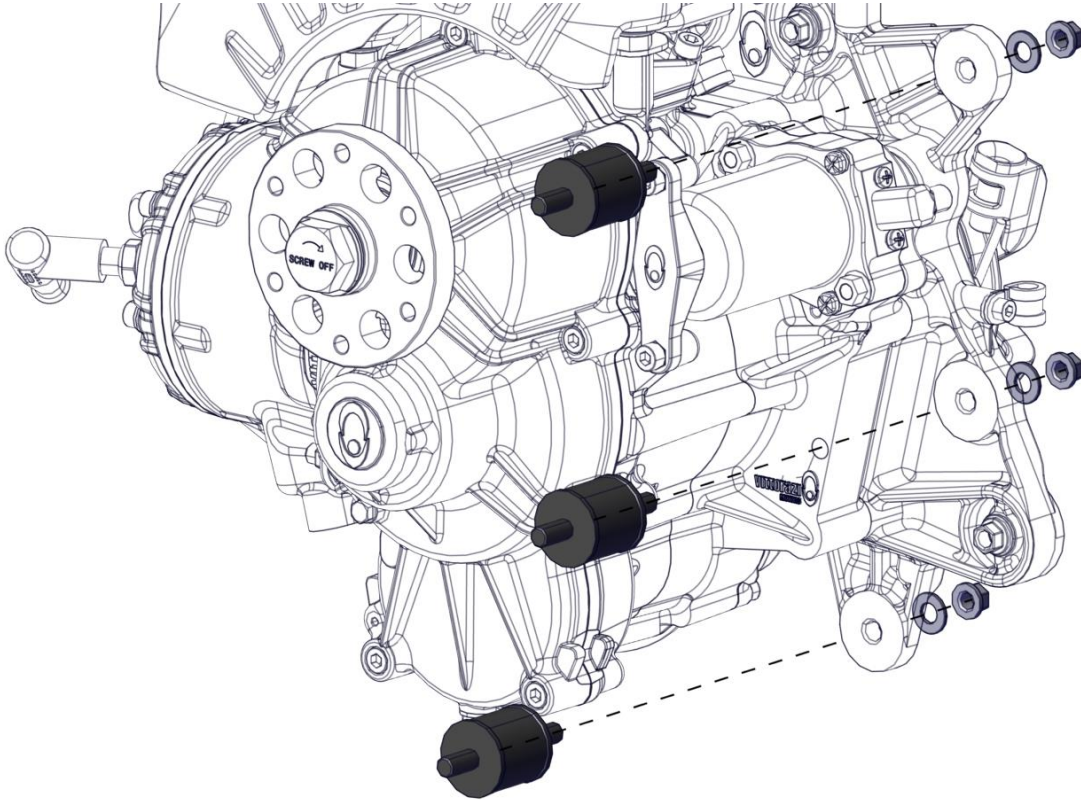

3.9.2 Rubber mountings maintenance



Check the integrity of the rubber mountings: there must be no cracks or detachment of material, otherwise they must be replaced. For routine maintenance, follow the table.

3.9.3 Rubber mountings assembly



Replace the safety belts, the 4 rubber mountings of the engine mount.

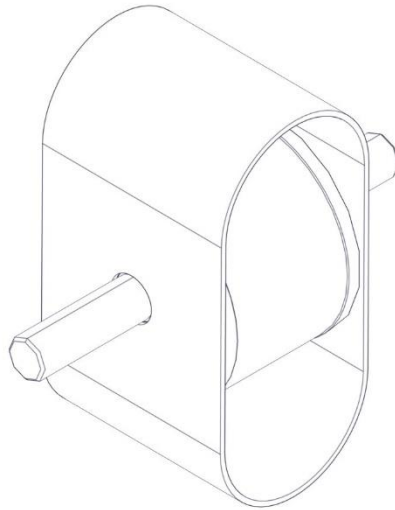

Replace the 4 self-locking nuts M8 each time they are disassembled.

Insert the 4 engine rubber mountings and the 4 self-locking nuts M8 with washers.

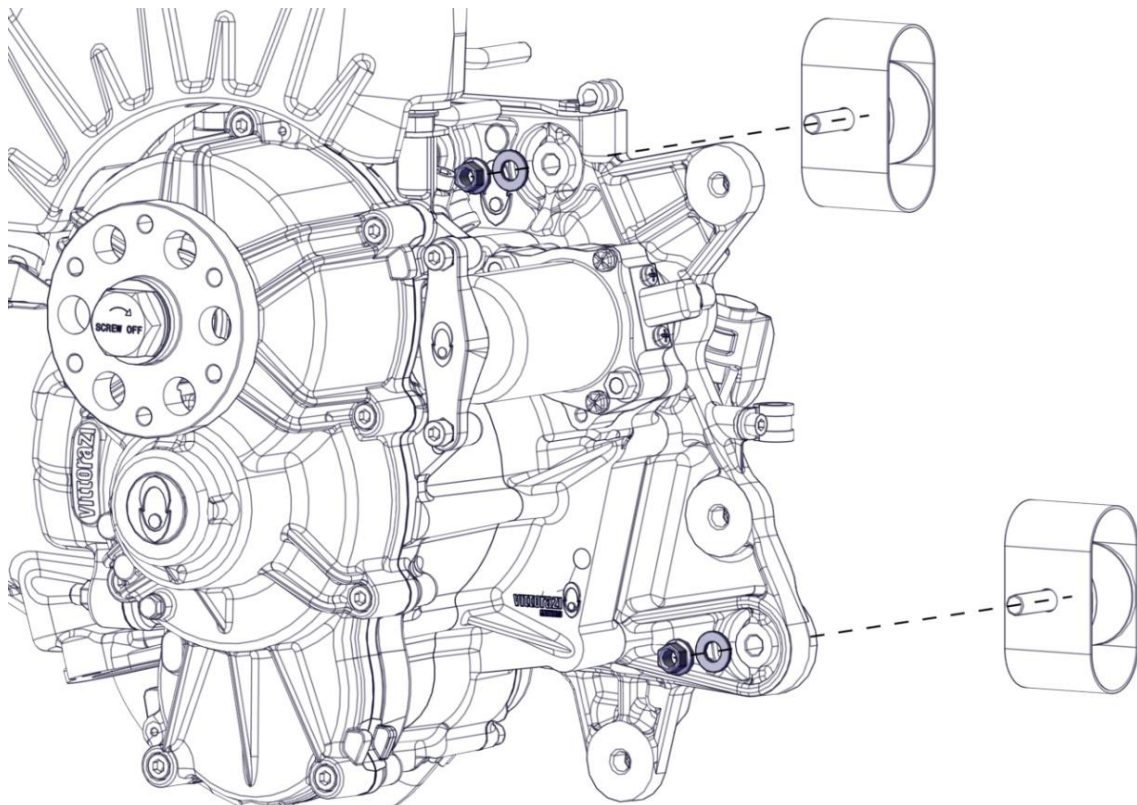

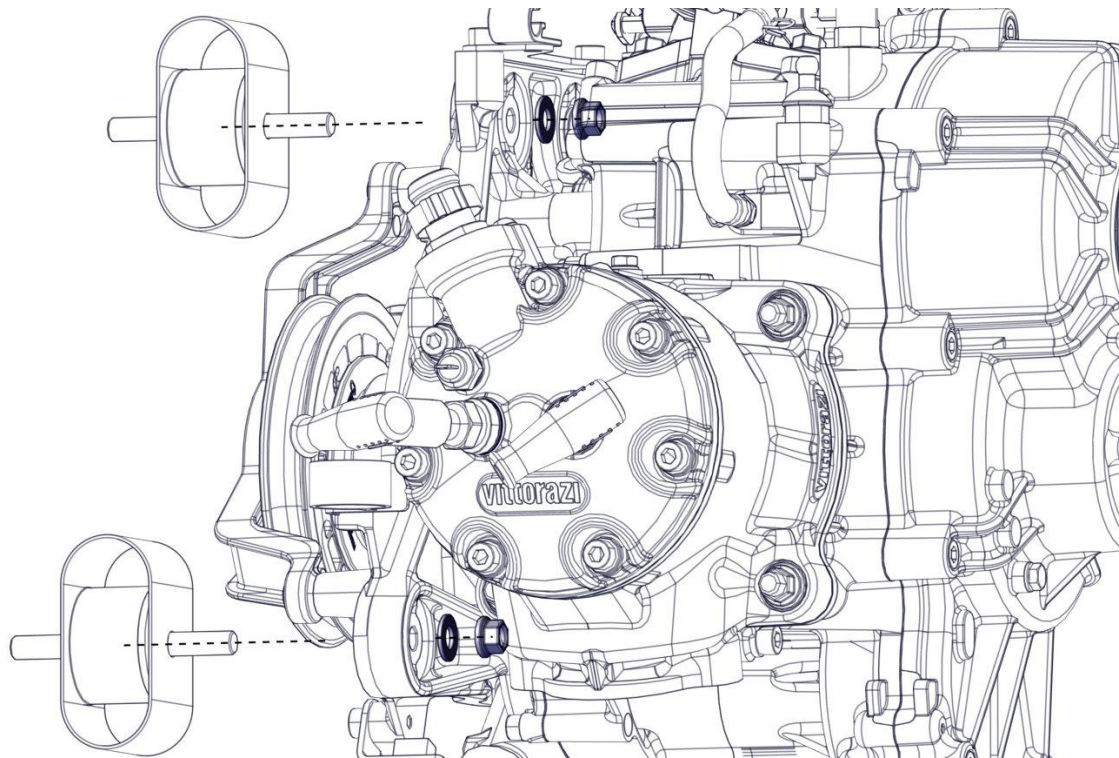

Replace the 3 self-locking nuts M8 each time they are disassembled.

Insert the 3 rubber mountings of the exhaust system, the 3 self-locking nuts M8 with washers and tighten with the torque shown in the figure.

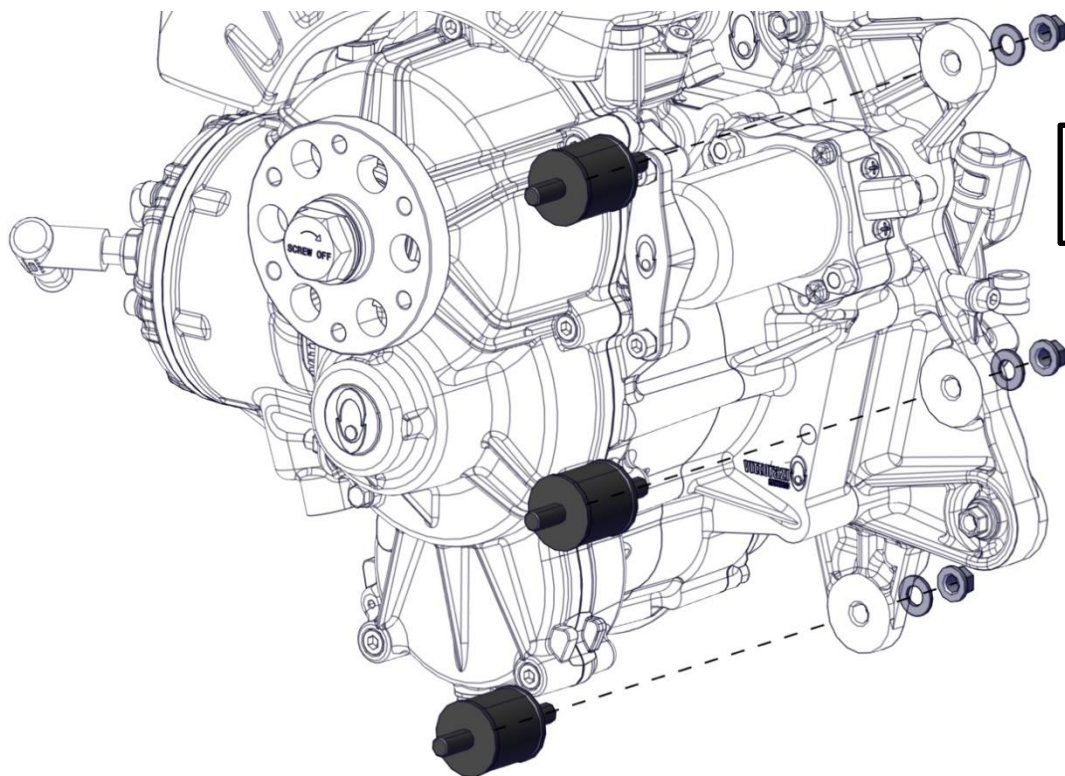

18 Nm

Insert the exhaust system.

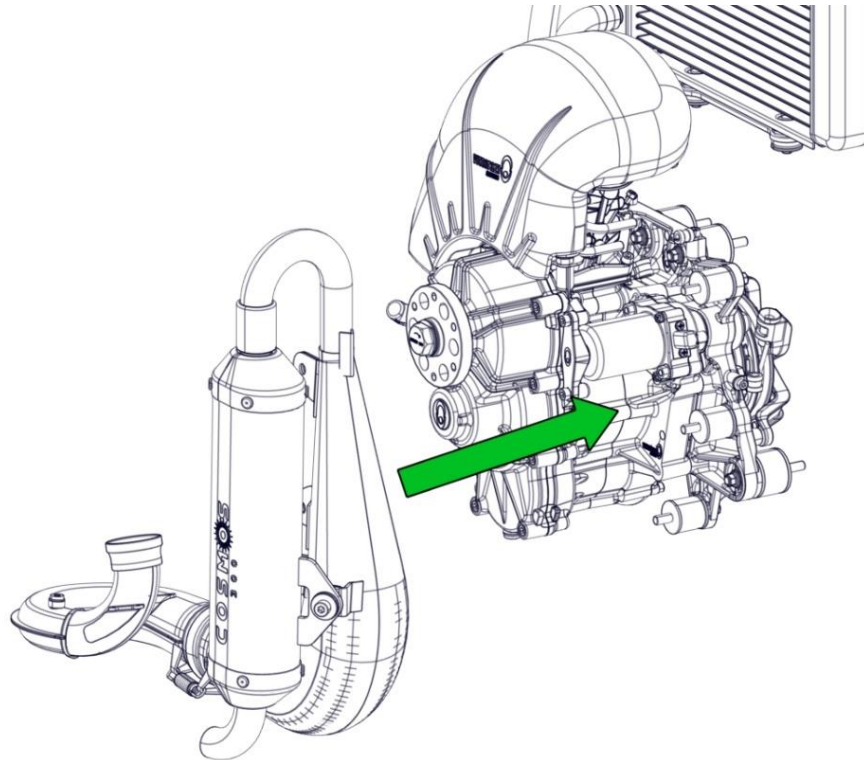

Replace the 3 self-locking nuts M8 each time they are disassembled.

Insert the 3 self-locking nuts M8 with washers and tighten with the torque shown in the figure.

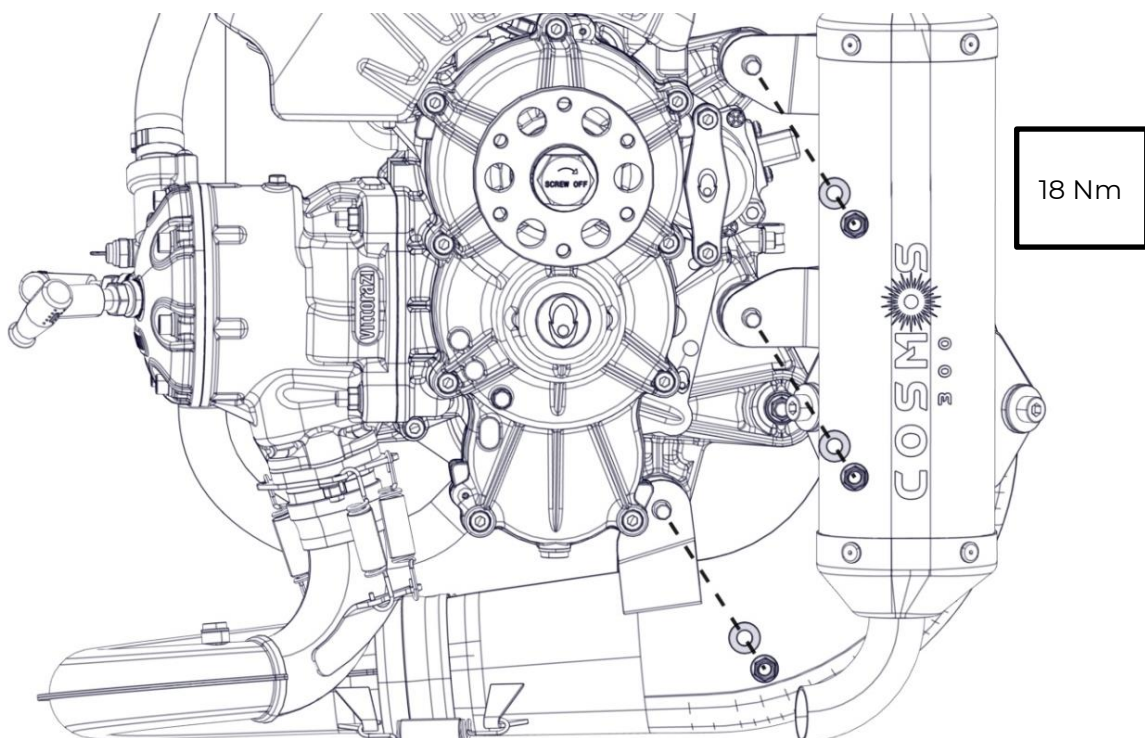



Hook in the 4 bushing springs.

Run a cable around the four bushing springs, insert a clamp on the ends and tighten with pliers.

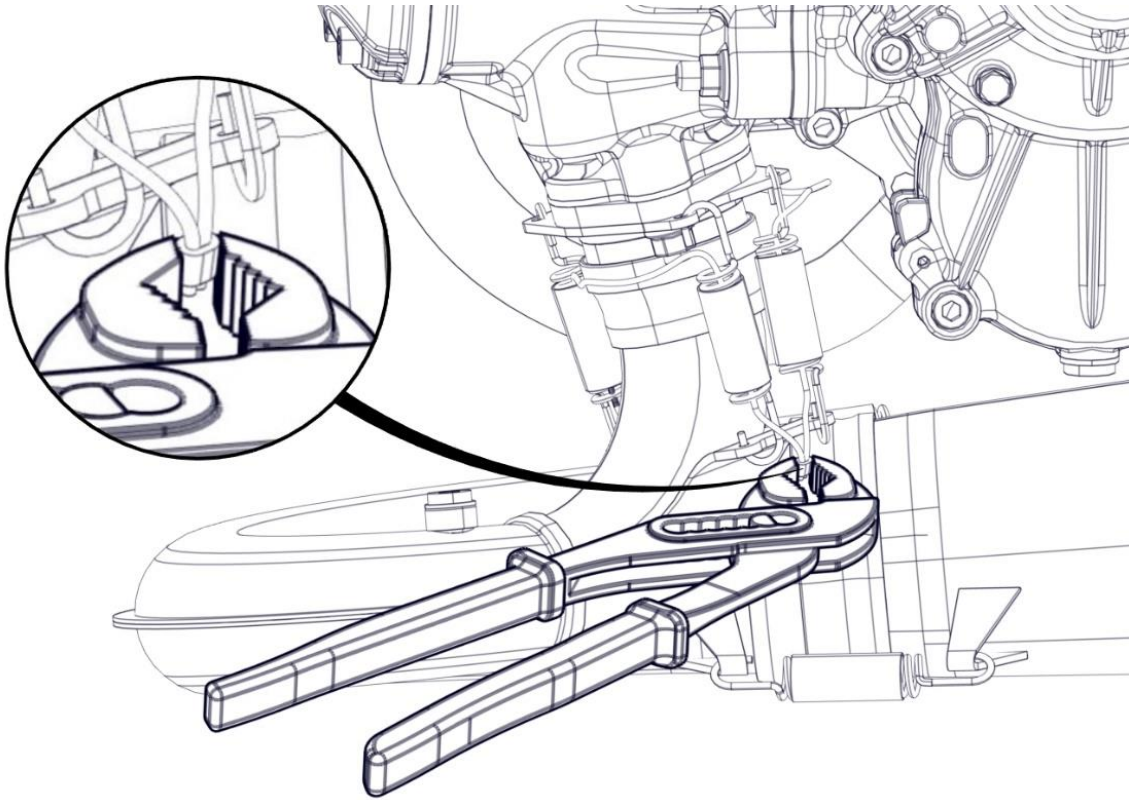
Apply heat shrinkable hoses



3.10 Pull starter system

 Components to replace		Time limit
	Rope (M043)	100 h
	Hooks spring (MP057)	100 h
	Hooks (MP055)	100 h
	Aluminium bushing (C042c)	on condition
	Nanotech lubricant*	100 h
	HHS grease*	100 h
	Loxal 83-55/Loctite 270*	100 h
	Loxal 24-18/Loctite 222*	100 h
Loxal 55-03/Loctite 243*	on condition	
 Special tools	Not required.	
 Values	Screws M6x25: 10 Nm. Aluminium bushing (C042c): 12 Nm	

*Always replace it when disassembled.

3.10.1 Pull starter system disassembly

Untie the knot securing the starter handle and pull the rope out of the guide eyelet.

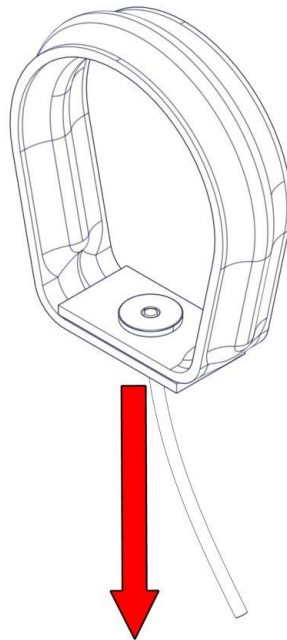

Allow the winding pulley to rotate so that the tension given by the recovery spring is lost.

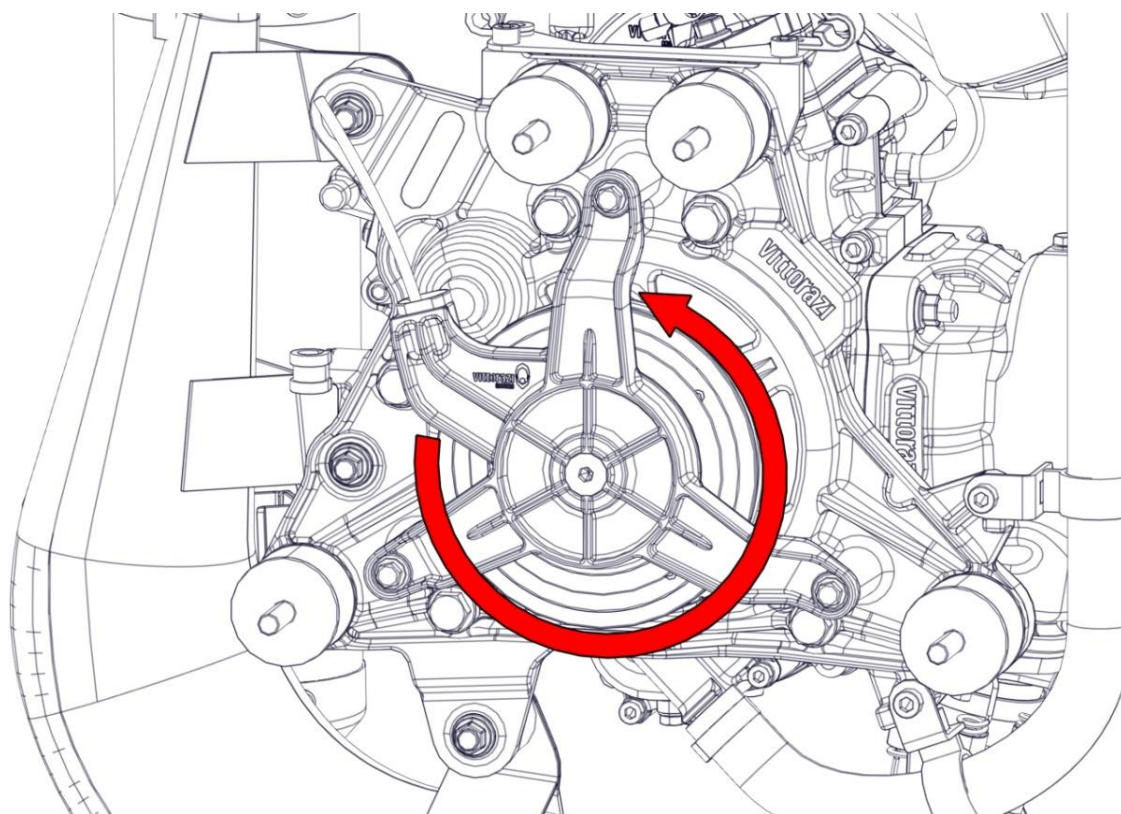

Remove the 3 flange head screws M6x25 (1) from the manual starter bracket (2).
After removing the manual starter, the cup (3) mounted on the flywheel is visible.

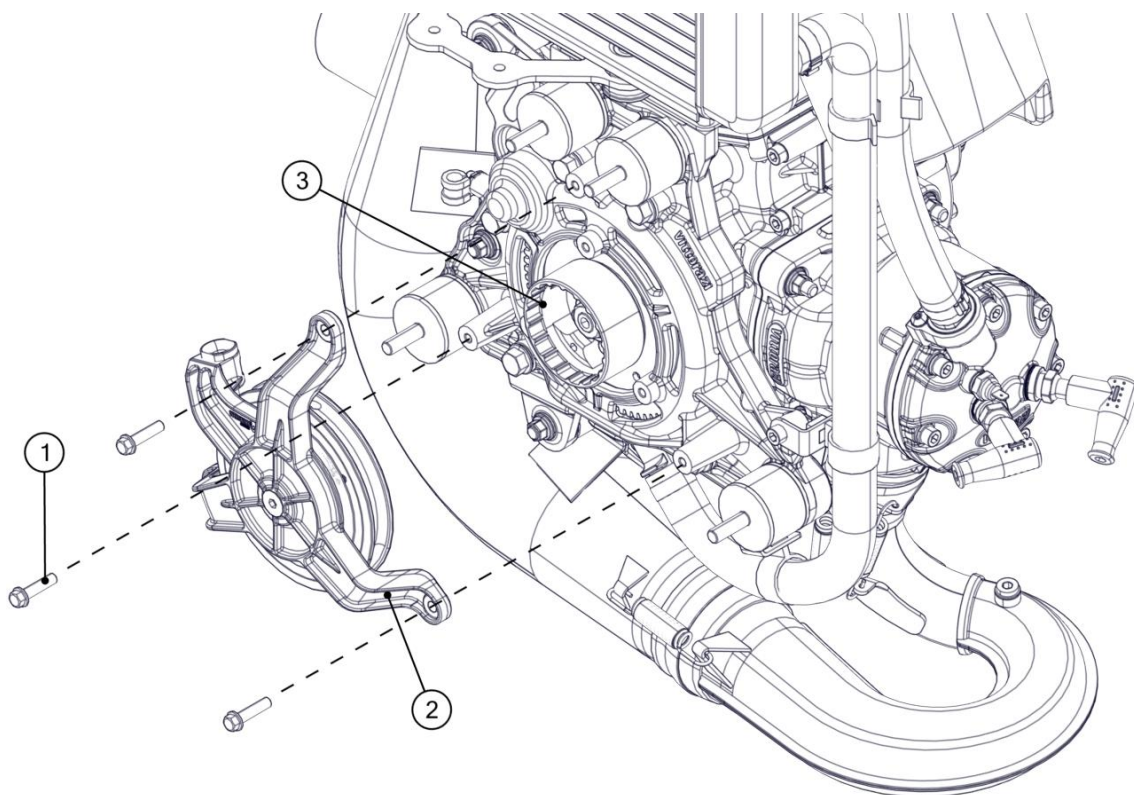

Remove the spring of the hooks (4), the 2 hooks (5), the washers (6) and the pulley (7) taking care to leave the recovery spring (8) in its place.

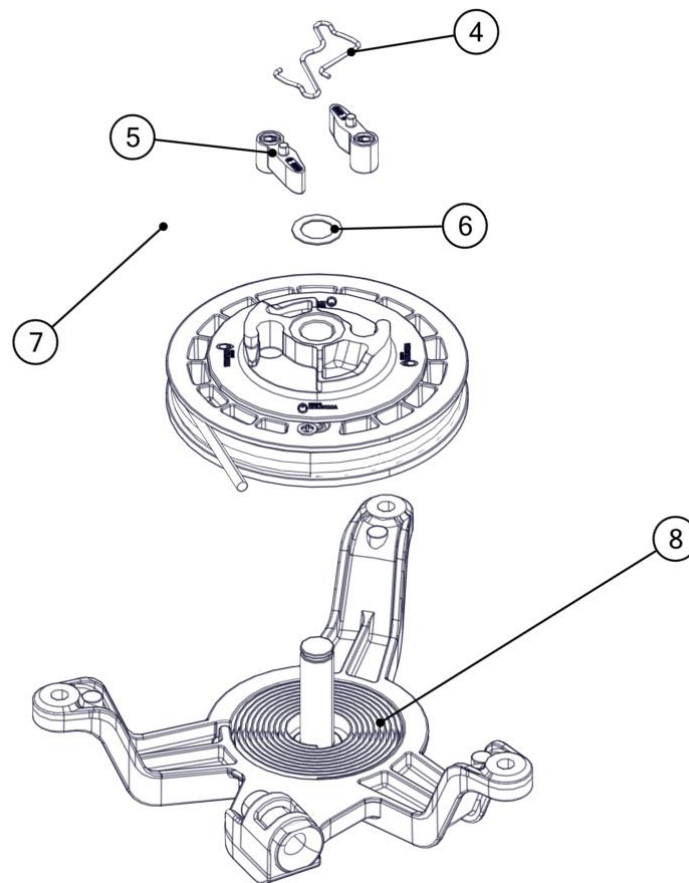

Remove the rope by untying the knot and pulling it off the pulley.

Unscrew the aluminium bushing (11) from the manual starter bracket (2).

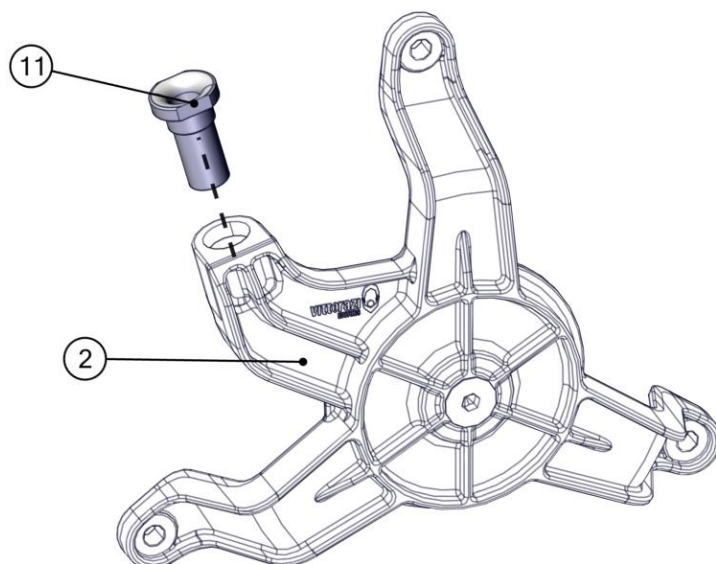
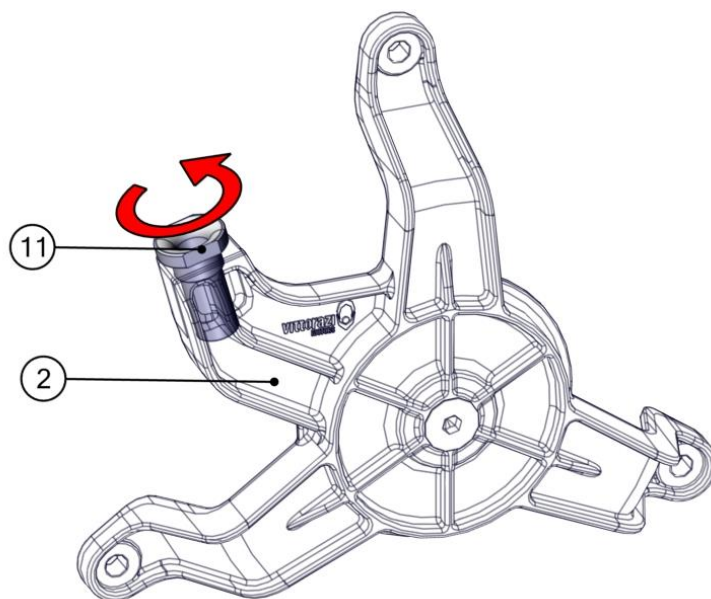

3.10.2 Pull starter system maintenance

Check the rope: replace it if it shows signs of wear. For routine maintenance, follow the table.

Check the spring of the hooks: if it shows signs of wear as in the picture, replace it. For routine maintenance, follow the table.

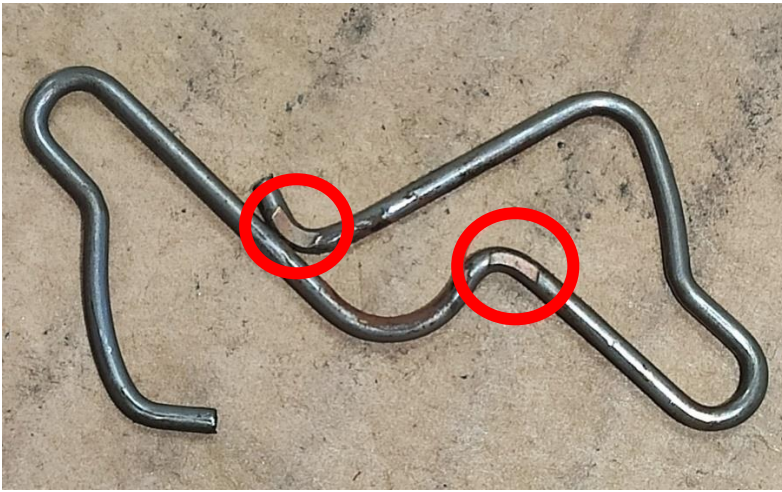

Check the hooks, in particular the tips must not be damaged, otherwise they must be replaced. For routine maintenance, follow the table.

Check the washers: if they show signs of wear as in the picture, replace them with new washers of the same thickness.



Check that the return spring is intact and not deformed, particularly in the area shown in the photo, otherwise replace it.



Insert the spring of the hooks on the central pin and turn it, if any blockage or jamming occurs the pin must be replaced.

Check the aluminium bushing: replace it if it shows signs of wear.



Failure to replace a worn pin can block the movement of the pulley and thus prevent the manual starter rope from being rewound correctly.

3.10.3 Pull starter system assembly



If the washers are different, place the thinner ones first and then the thicker ones.

Insert the washers (6), the 2 hooks (5) and the spring of the hooks (4).

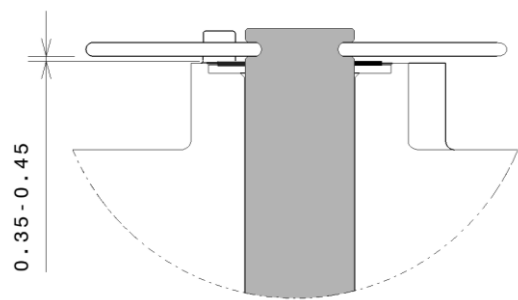
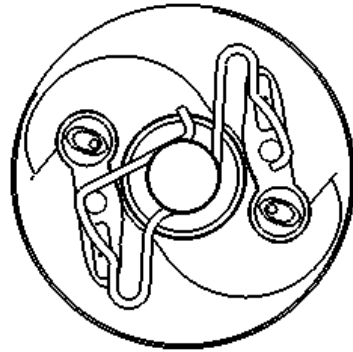
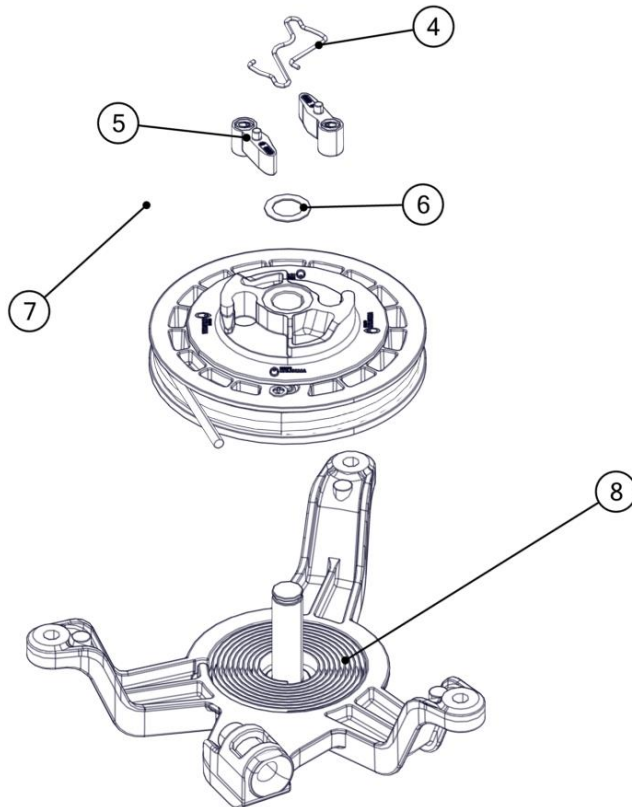

Insert the aluminium bushing (11) on the manual starter bracket (2) with threadlocker (Loxéal 55-03/Loctite 243 recommended) and tighten with the torque shown in the figure.

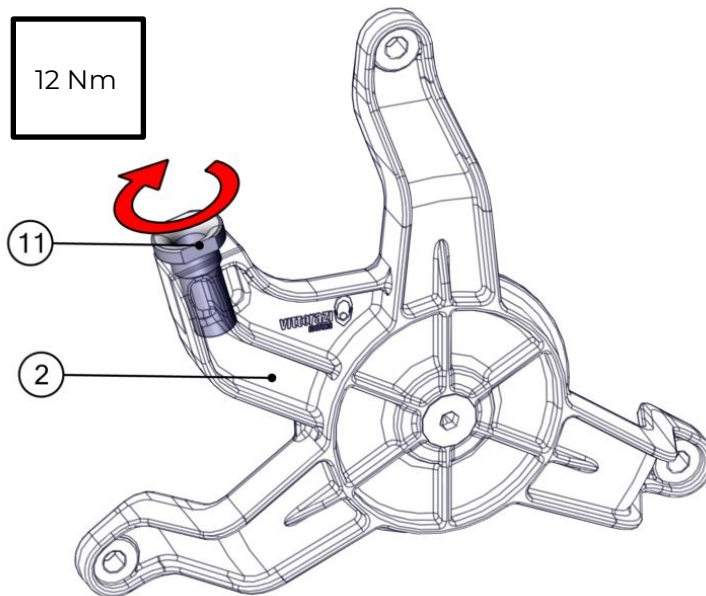
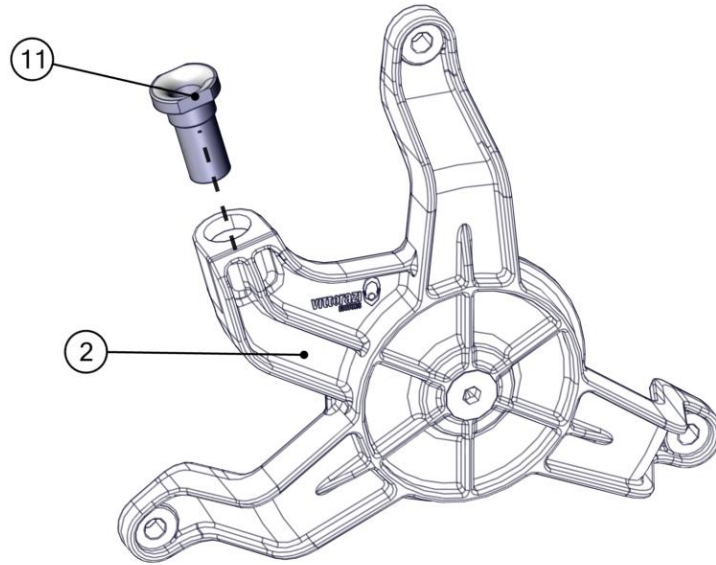

Preload the pulley:



Turn the pulley until you find the origin of the spring tension.

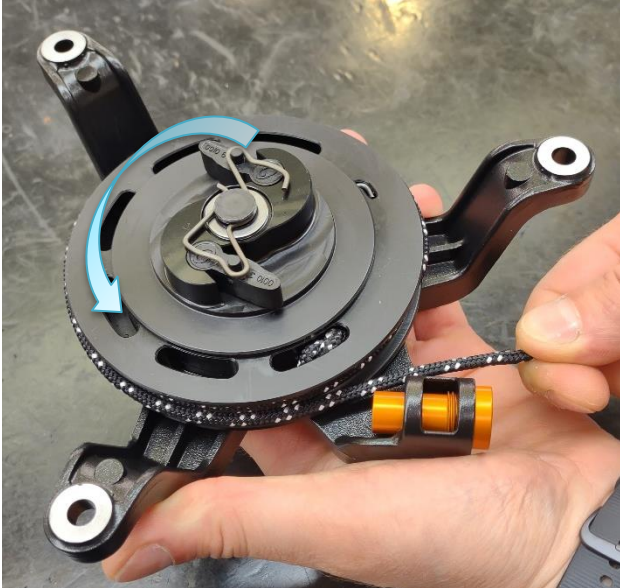

Hold the pulley in place and wind 3 turns of rope counterclockwise.

Turn the pulley 3 turns counterclockwise to get the correct preload for the recovery spring.

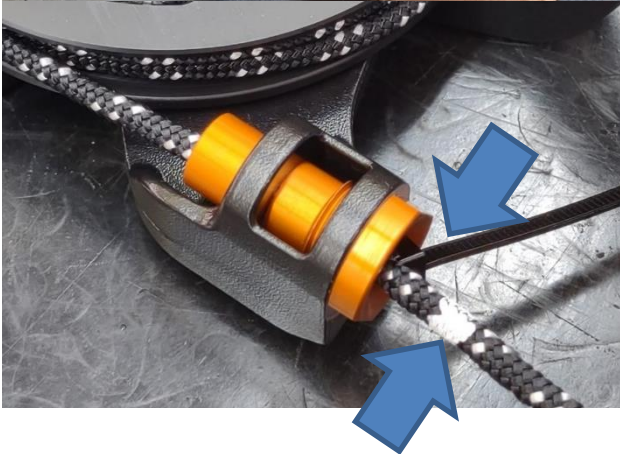

Insert the rope into the rope guide.

Secure the rope with a cable tie and make a mark on the rope.



Before final assembly of the manual starter on the engine, check that the hooks are in the closed position, otherwise they may be damaged.

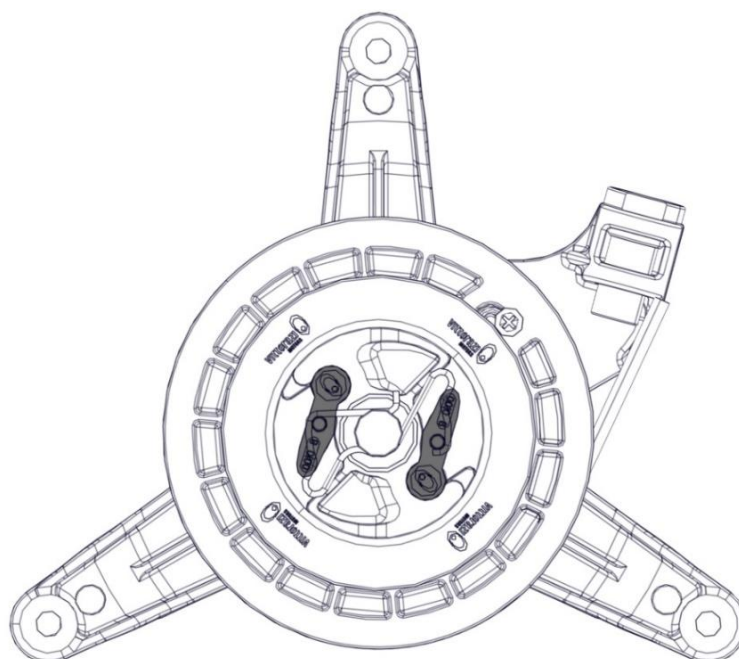

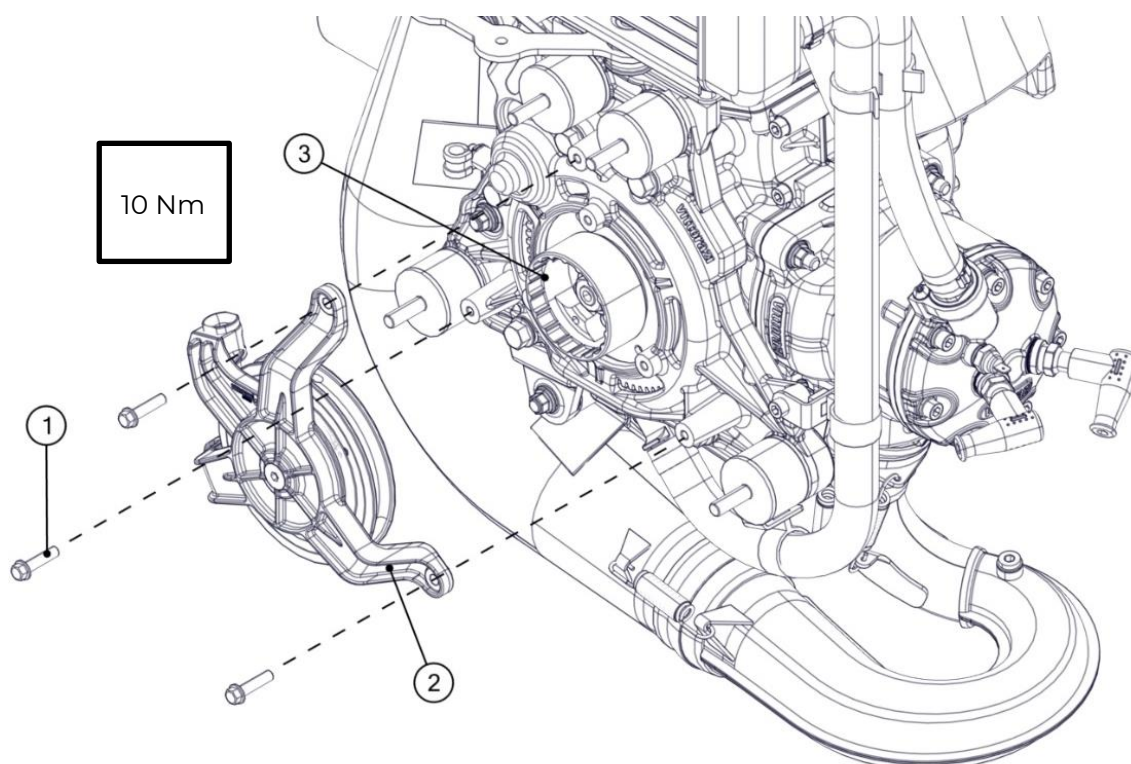

Insert the 3 flange head screws M6x25 (1) with threadlocker (Loxéal 24-18/Loctite 222 recommended) into the manual starter bracket (2) and tighten with the torque shown in the figure.



Insert the rope into the guide eyelet of the handle and tie a knot to prevent it from slipping out. Pull the handle and check that the pulley rotates smoothly without blocking.

3.11 Electric starter

 Components to replace		Time limit
	Electric starter (C301)	on condition
 Special tools	Not required.	
 Values	Screws M6x35: 10 Nm. Screws M6x20: 10 Nm.	

3.11.1 Electric starter disassembly



Disconnect the battery.

Remove the 2 Allen screws M6x20 (1) from the electric starter plate (2).
Remove the 2 flange head screws M6x35 (3) from the electric starter.
Remove the electric starter (4) from the crankcase housing (5).
Remove the O-ring (6) from the electric starter.

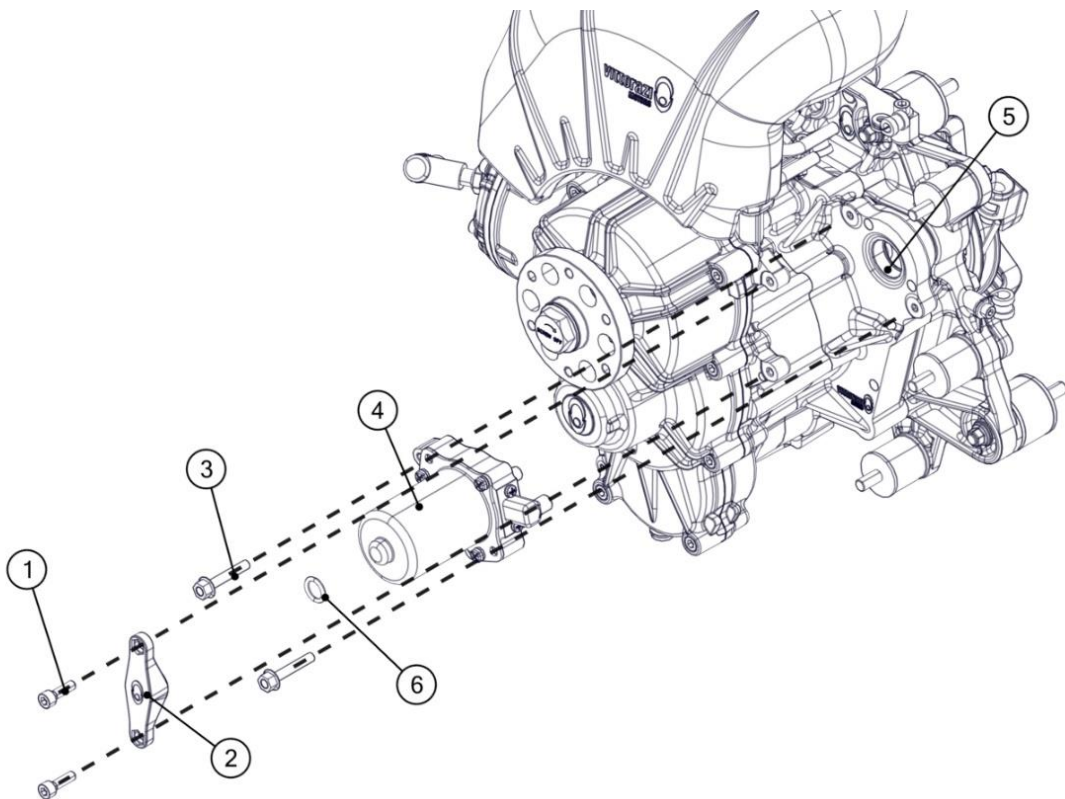

3.11.2 Electric starter maintenance

Check the teeth of the electric starter and Bendix: if they show signs of wear, replace the components.

3.11.3 Electric starter assembly



Replace the O-ring (6) each time it is disassembled.

Fit the O-ring (6) on the electric starter (4).

Insert the electric starter (4) into the crankcase housing (5).

Insert the 2 flange-head screws M6x35 (3) into the electric starter (4) and tighten with the torque shown in the figure.



Insert the O-ring (6) on the rear of the electric starter (4).

Position the reinforcement plate (2).

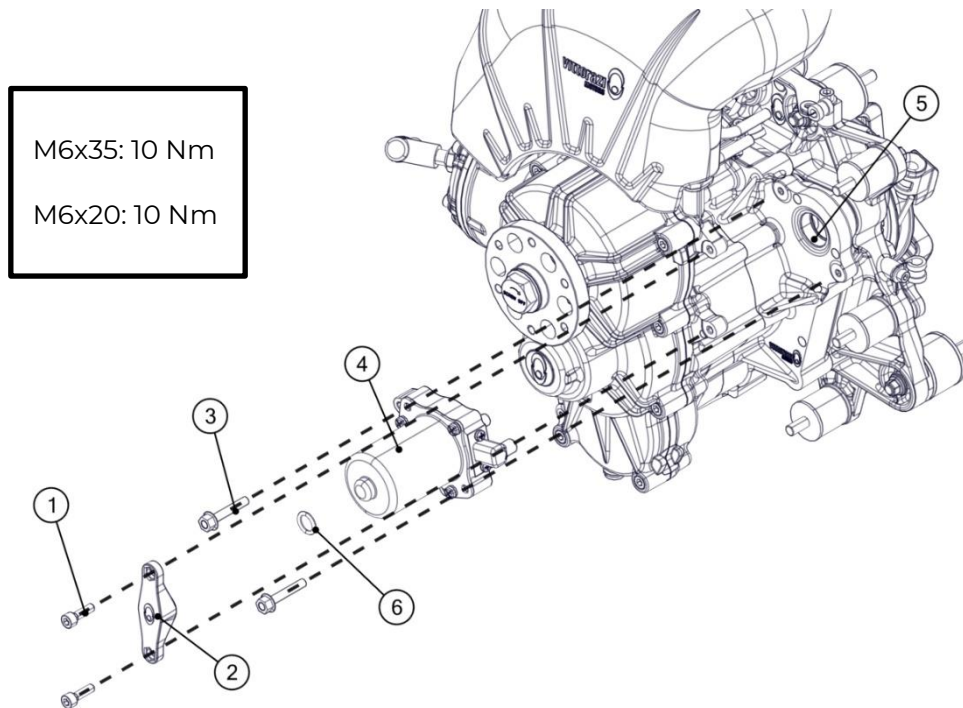
Insert the 2 Allen screws M6x20 (1) in the plate (2) and tighten with the torque shown in the figure.



3.12 Flywheel (and Bendix)

 Components to replace		Time limit
	Flywheel (C034, C038, C039)	on condition
	Nut M12x1,25 and washer (C037)	200 h
	Loxéal 83-55/Loctite 270*	
 Special tools	Flywheel locking tool (ACC110). Flywheel extractor (ACC105).	
 Values	Nut M12x1,25: 90 Nm. Screws M8x55: 20 Nm. Screws M5x14: 8 Nm. Screws M6x25: 10 Nm. Screws M6x20: 10 Nm	

*Always replace it when disassembled.



Remove the Exhaust System before disassembling.

3.12.1 Flywheel disassembly

Remove the 5 flange-head screws M8x55 (1) with washers (2) from the support plate (3).
 Remove Bendix (5) from its housing and the Bendix washer (4).

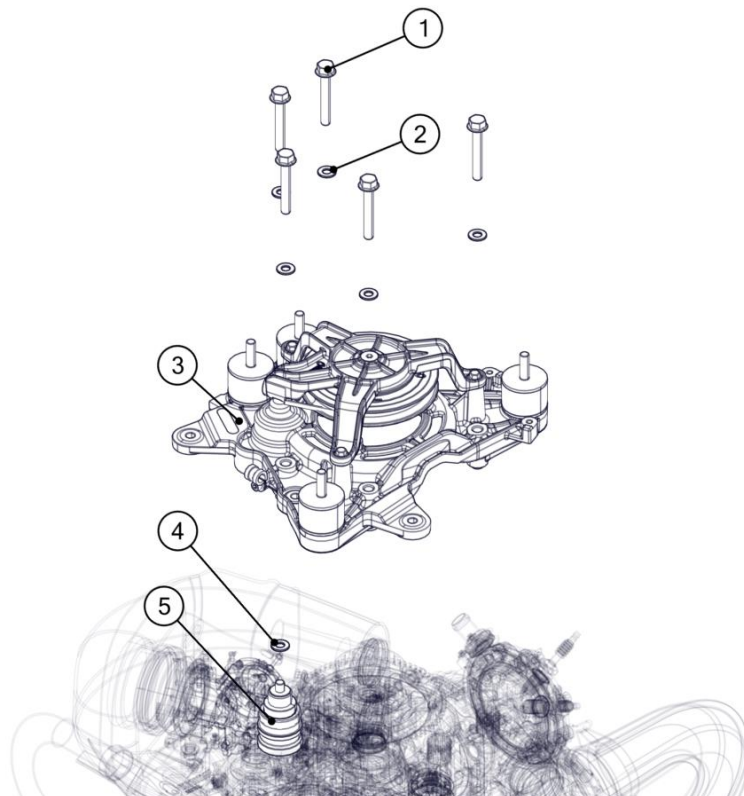

Position the 2 pins of the flywheel locking tool [ACC110] in the 2 holes of the flywheel (8).
Hold the end of the flywheel locking tool and remove the M12x1,25 nut (6) with the 12x22x1 washer (7).

Screw the flywheel extractor (ACC105) into the starter cup.

Turn the central pin of the extractor until the flywheel is removed from the crankshaft.

Check that the key (9) remains in the shaft.

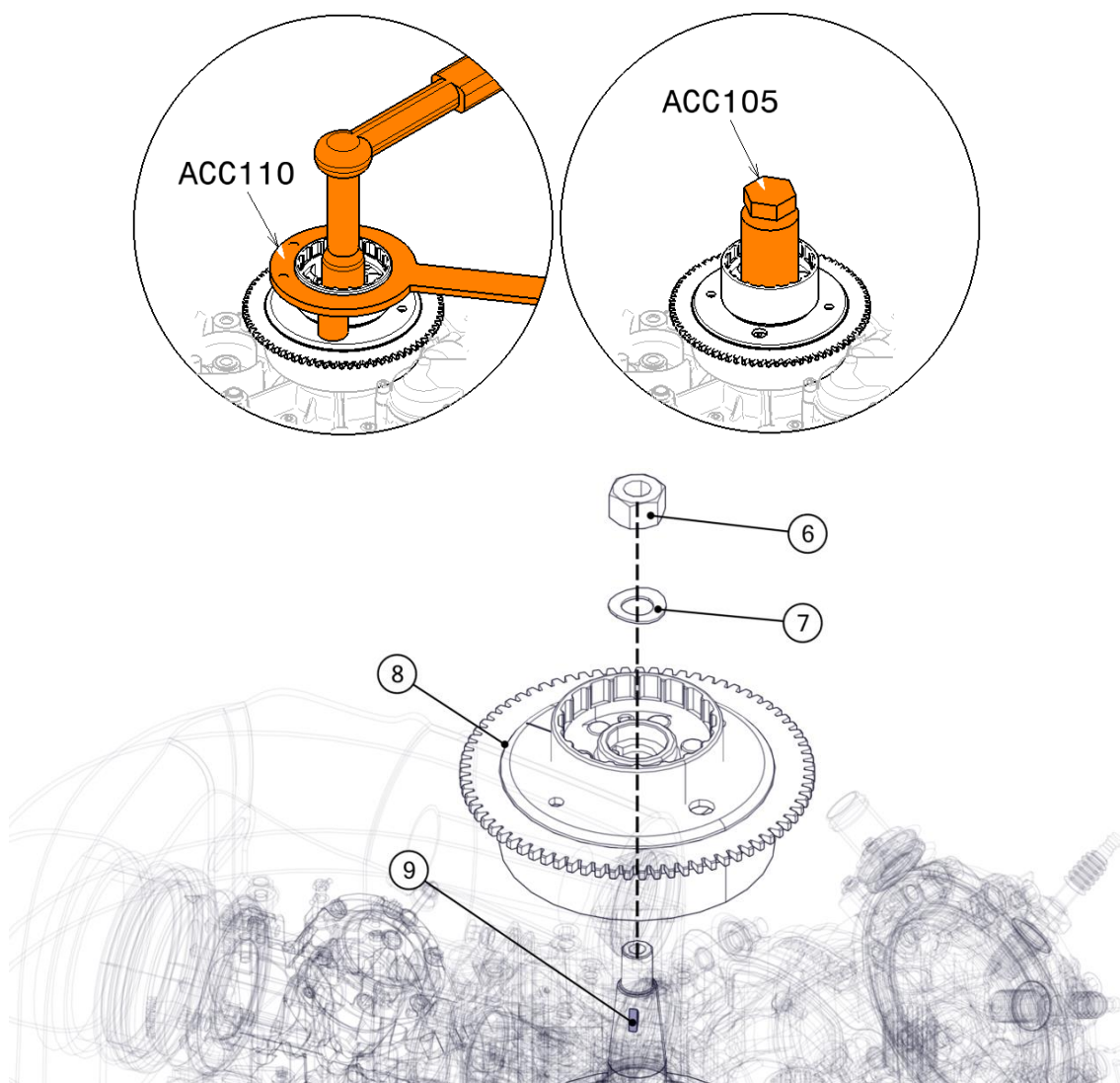

Remove the 2 screws M5x14 (14) and the cable ties (15).
Remove the 2 Allen screws M6x25 (11) and the stator (10).
Remove the 2 Allen screws M5x14 (12) and the pick-up (13).

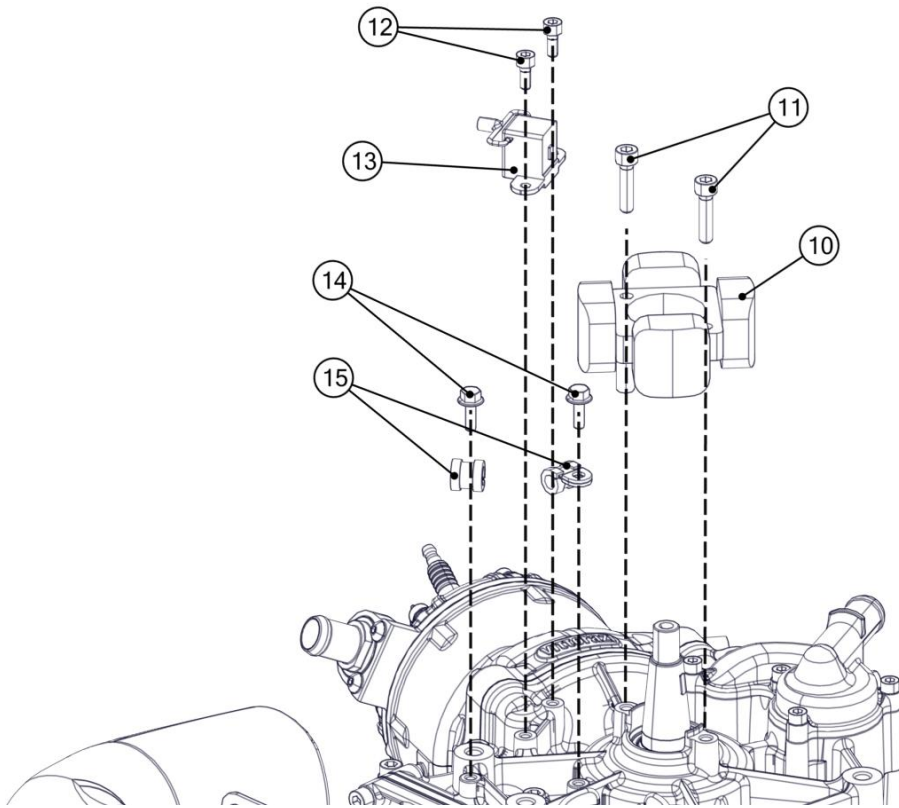

Remove the 3 countersunk screws M6x20 (16) to disassemble the pull starter cup (18) from the flywheel (17)

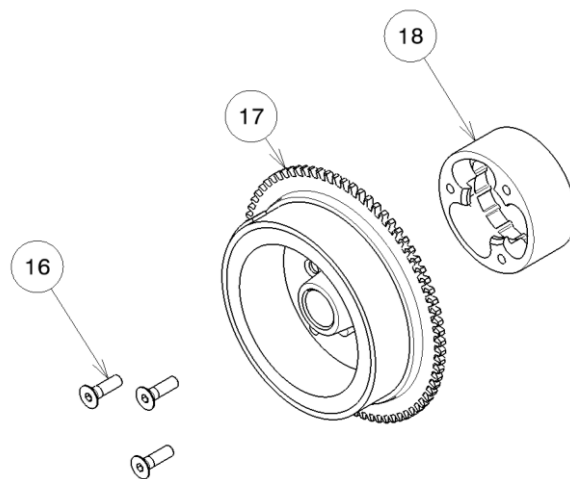

3.12.2 Flywheel maintenance

Check the integrity of the flywheel: there must be no cracks or damaged areas, otherwise replace it.



Check the ring gear teeth: If they show excessive signs of wear, replace the flywheel.

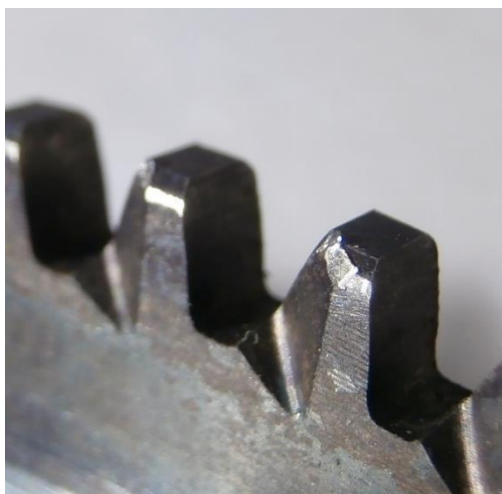

Check that the Bendix teeth are not broken or excessively worn.



Check that the Bendix bushings are not worn



Check that the stator wires are still flexible and not broken.

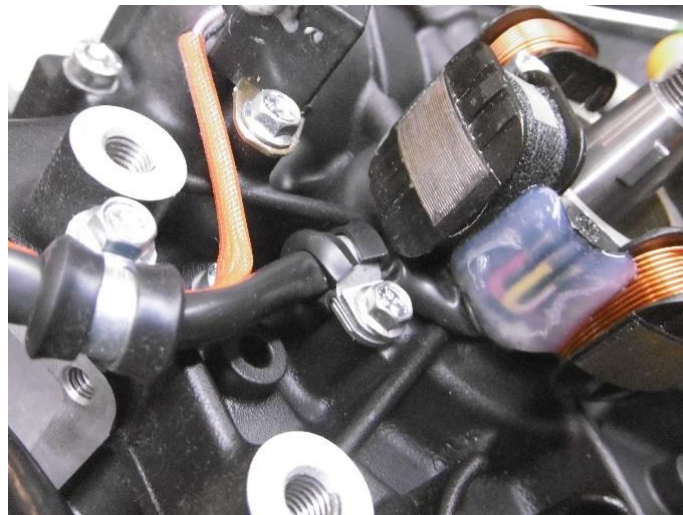

3.12.3 Flywheel assembly

Insert the pick-up (13), the 2 Allen screws M5x14 (12) and tighten with the torque shown in the figure.

Insert the stator (10), the 2 Allen screws M6x25 (11) and tighten with the torque shown in the figure. Insert the 2 cable ties, the 2 screws M5x14 (12) and tighten with the torque shown in figure.



Position the stator and the wiring according to the image below.

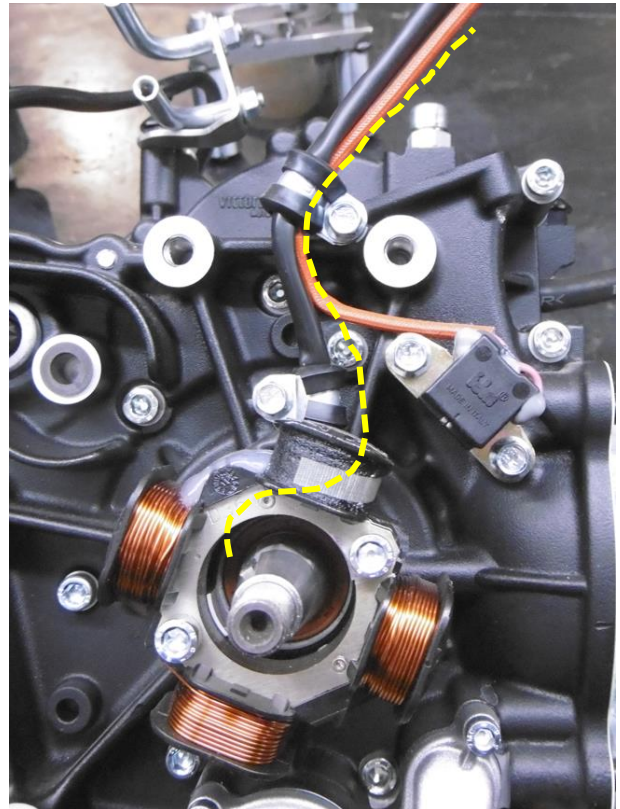
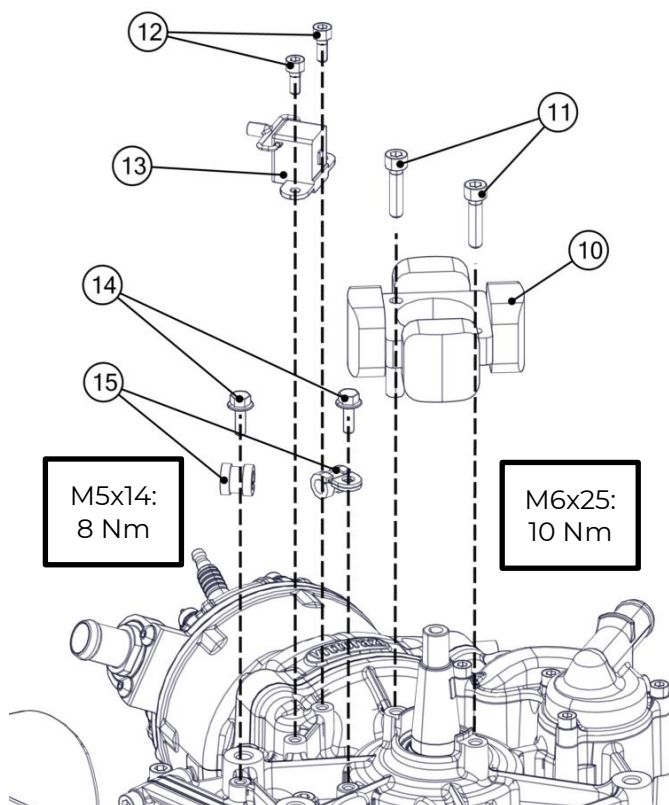

Respect the orientation of the cable ties (15).

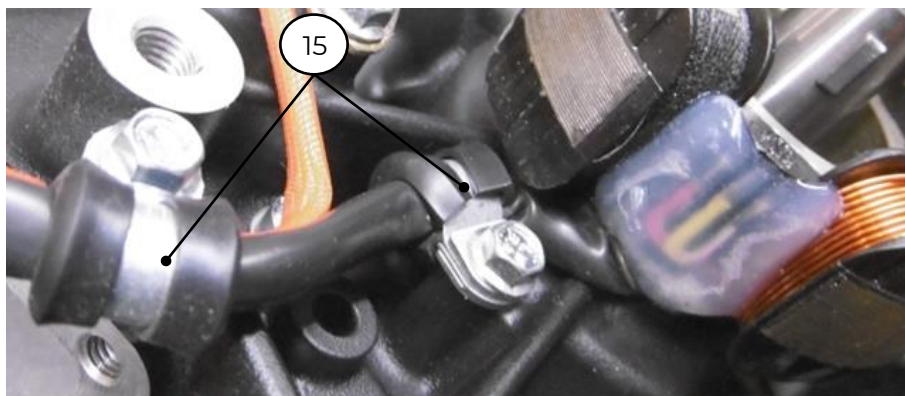

Fasten the pull starter toothed cup (18) to the flywheel (17) with 3 screws M6x20 (16) if disassembled.

Tighten the 3 screws M6x20 (16) with the torque shown in figure.

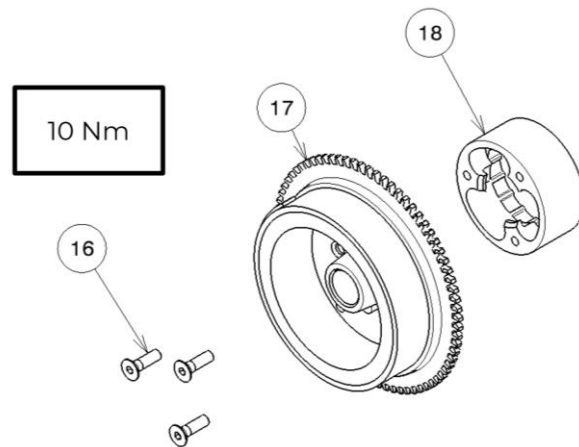

Replace the nut M12x1,25 and washer 12x22x1 each time they are disassembled.

Position the flywheel (8) on the crankshaft by aligning the key (9) with the flywheel groove.

The position of the key and therefore of the flywheel determines the timing of the engine.

Insert the nut M12x1,25 (6) with the washer 12x22x1 (7) and tighten it by hand. Position the washer (7) according to the image in the following page.

Position the 2 pins of the flywheel locking tool [ACC110] in the 2 holes of the flywheel (8).

Hold the end of the flywheel locking tool and tighten the nut (6) with the torque shown in the figure.

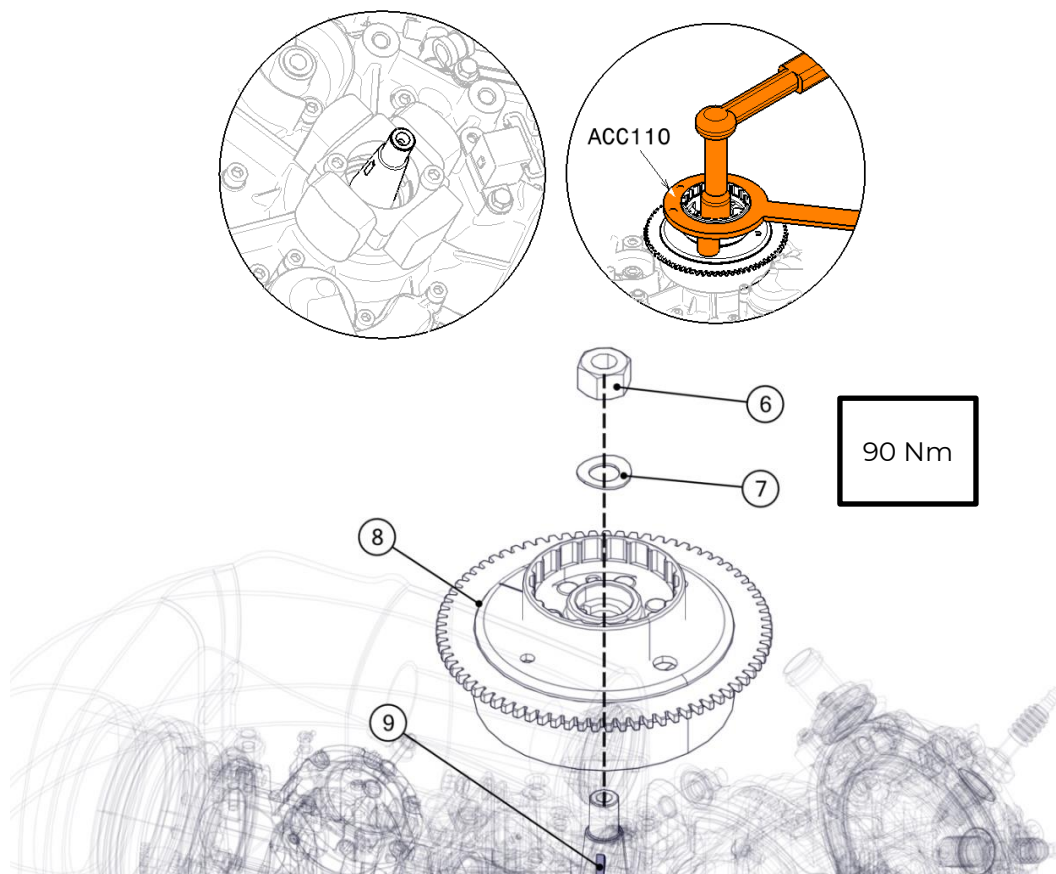







Pay attention at the orientation of the washer 12x22x1: the knurled side must be in contact with the nut.

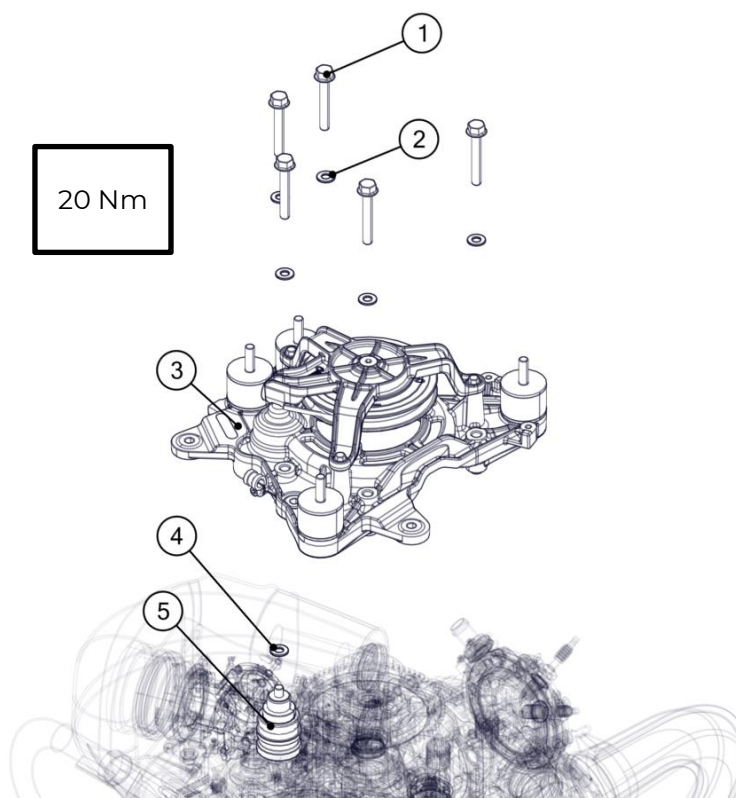

Insert the Bendix (5) and the shim ring (4) into its housing.
Position the support plate (3) on the engine casing.
Insert the 5 flange-head screws M8x55 (1) with washers (2) into the support plate and tighten with the torque shown in figure.



3.13 Transmission

 <p>Components to replace</p>		Time limit	
	Transmission bearings (C106, C108)	200 h	
	Centrifugal clutch (C102)	200 h	
	Bushing (C114a)	200 h	
	Copper seals* (F159, AT162, AT162a)	50 h	
	Gasket* (C109)	200 h	
	Oil seal* (C113)	200 h	
	O-ring* (C114a)	200 h	
	Washer* (C101a)	200 h	
	Compensator ring* (C101b)	200 h	
	Driving gear (C100)	on condition	
	Driven gear (C101)	on condition	
	Clutch bell (C105)	on condition	
	Propeller shaft (C107)	on condition	
	Propeller hub (C115p)	on condition	
	Propeller hub (C115u)*	on condition	
	Key (C001a)	on condition	
	Transmission cover (C110)	on condition	
	Transmission oil (C120)	50 h	
	Fixing bolt (C116a)	on condition	
Anti-unscrewing washer* (C116b)	200 h		
FP Silicompound 225*	200 h		
Loxal 55-03/Loctite 243*	200 h		
 <p>Special tools</p>	Propeller hub locking tool (ACC110). 2 set screws M4x30 (ACC111). Transmission locking tool (ACC112). Extractor (ACC113). Specific tool (ACC114). Clutch assembly tool (ACC115). 1000 kg press		
	 <p>Values</p>	Screw M8: 28 Nm. Nut M12x1,25: 72 Nm. Screws M5x14: 8 Nm. Nut M14x1,5: 100 Nm. Screws M6x30: 10 Nm. Upper cap: 10 Nm. Lower cap: 10 Nm. Oil bottle: 250 ml.	

*Always replace it when disassembled.



Before proceeding with the next operations on the transmission, remove the airbox (3.3 Airbox).

3.13.1 Oil replacement

Place a container under the transmission to collect the oil.

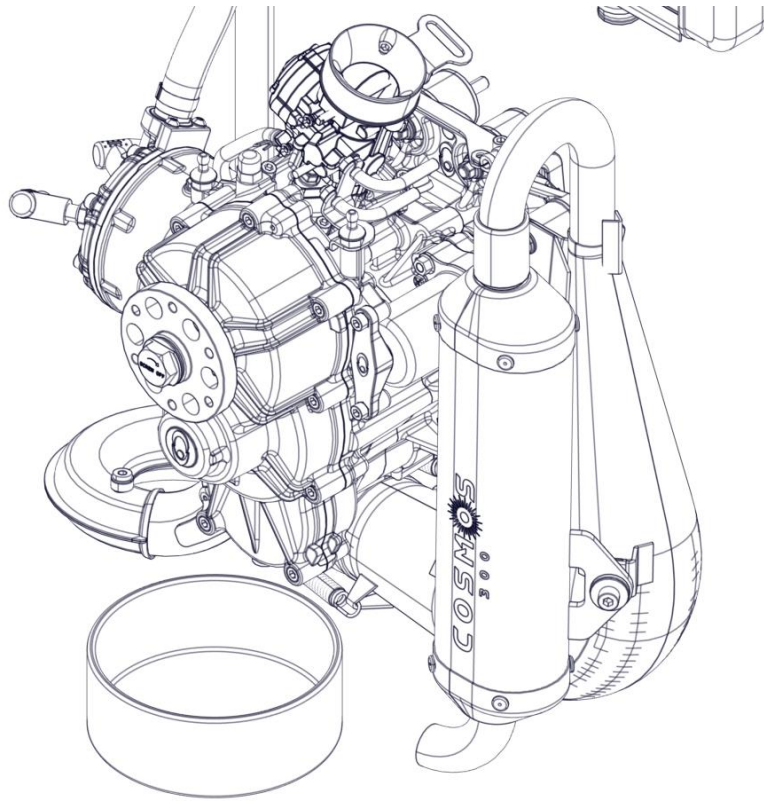

Remove upper cap with copper seal.

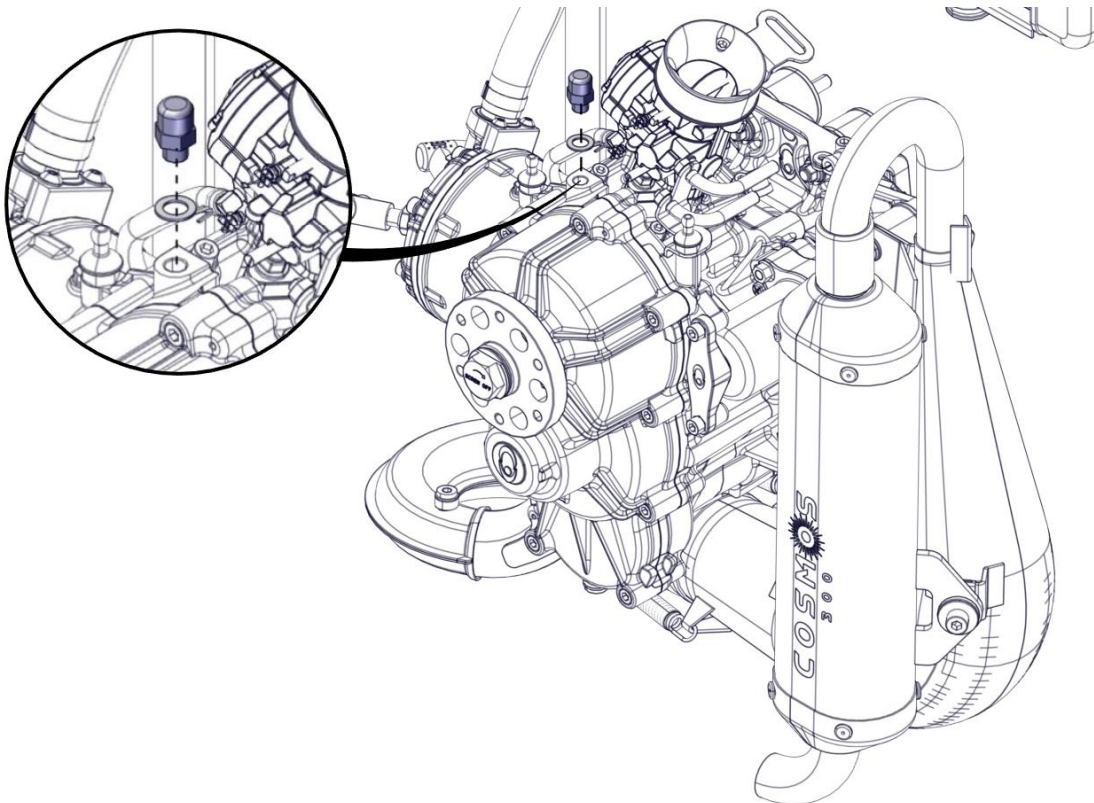

Place the engine in a vertical position and remove the lower cap with copper seal. Wait a few minutes for all the oil to drain.

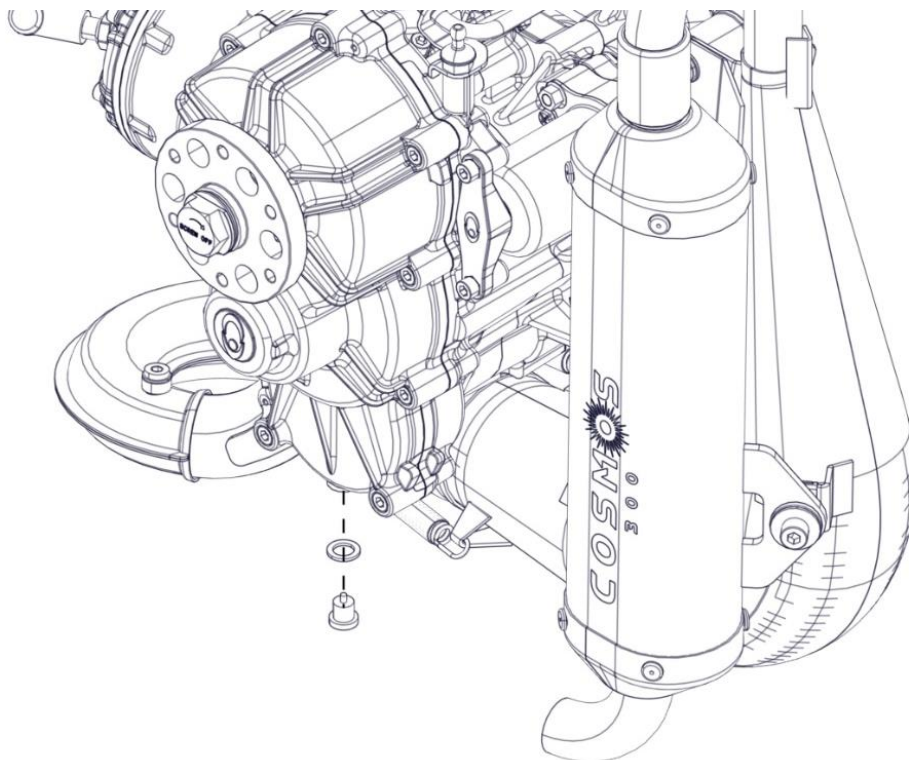

Replace the copper seal each time it is disassembled.

Clean the lower cap, insert it with copper seal and tighten with the torque shown in the figure.

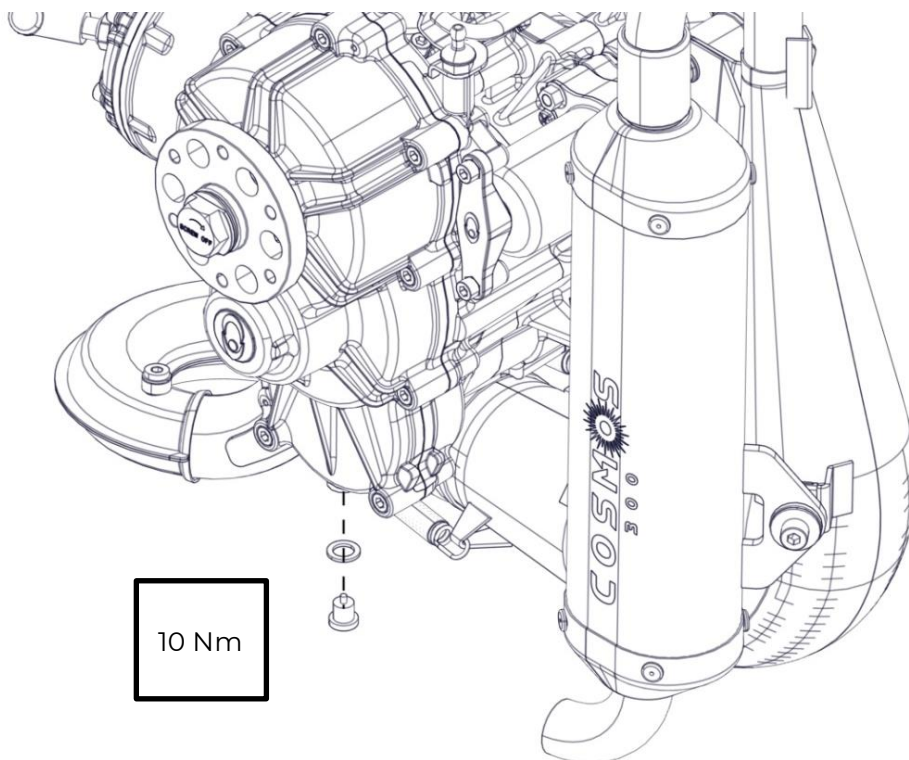

Remove front screw M5x10 with copper seal.

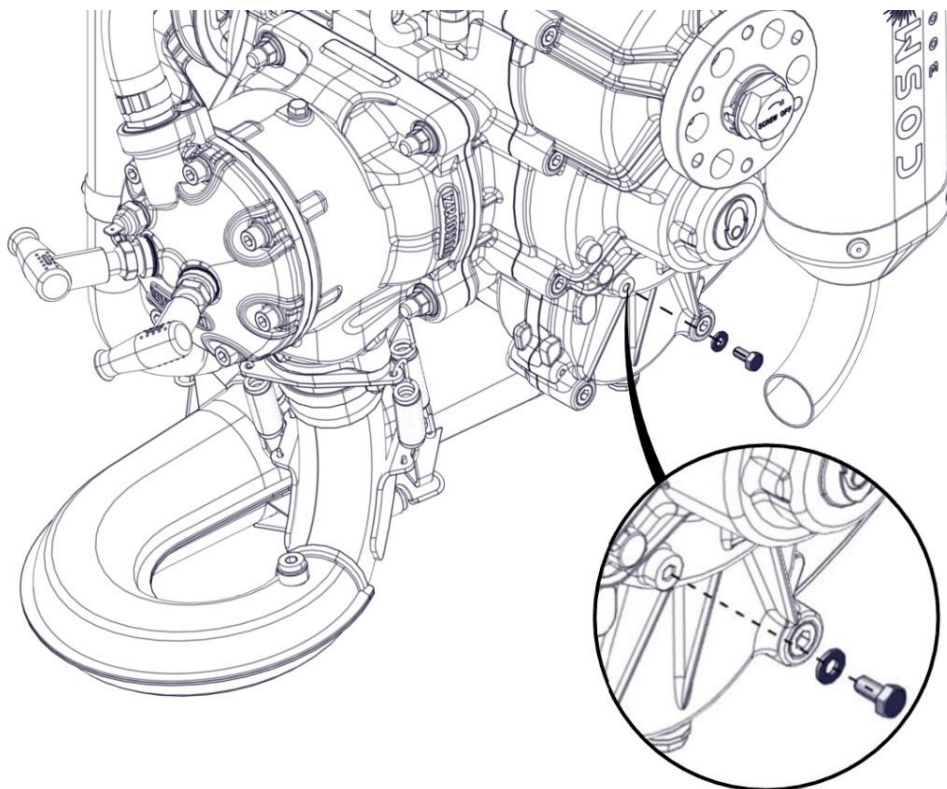

Fill the transmission with the specific oil (Motul Transoil 10W-40). Vittorazi supplies 250 ml bottle (C120) that is required to fill completely the transmission box.

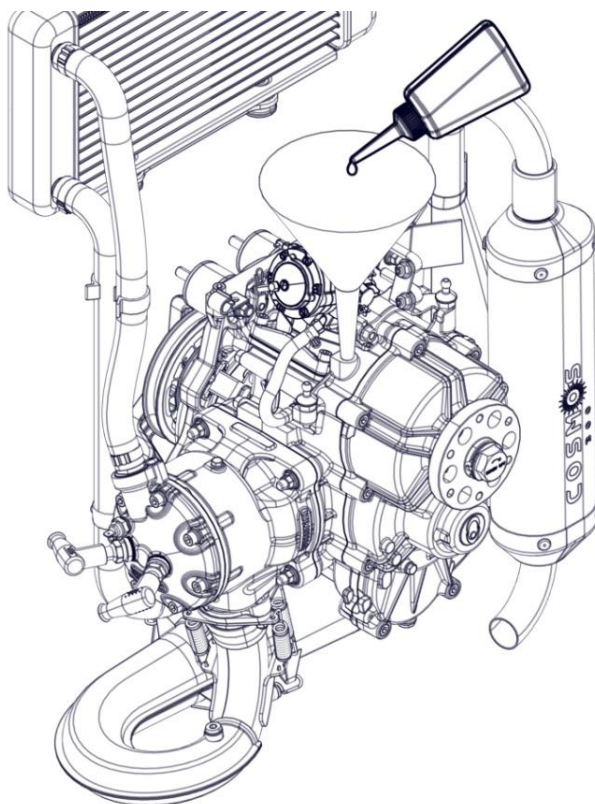

Fill the oil until it is leaking from the front hole.
Wait a few minutes for the oil to settle.



Replace the copper seal each time it is disassembled.

Insert front screw M5x10 with copper seal and tighten with the torque shown in the figure.

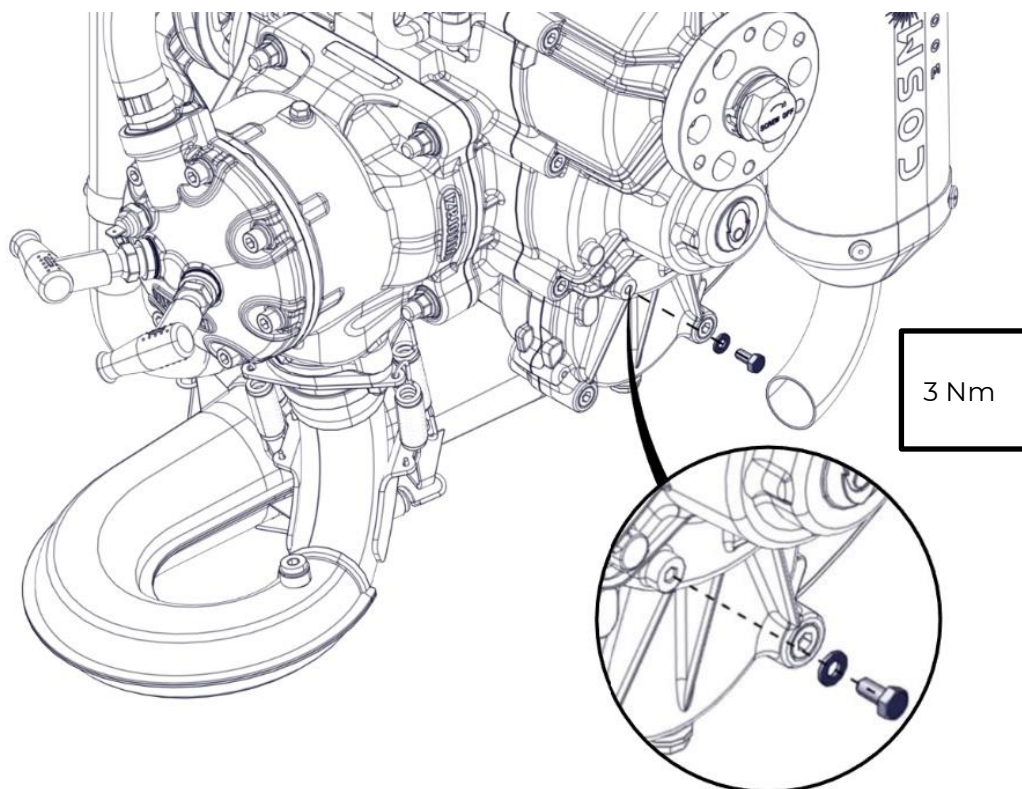



Replace the copper seal each time it is disassembled.

Insert upper cap with copper seal and tighten with the torque shown in the figure.

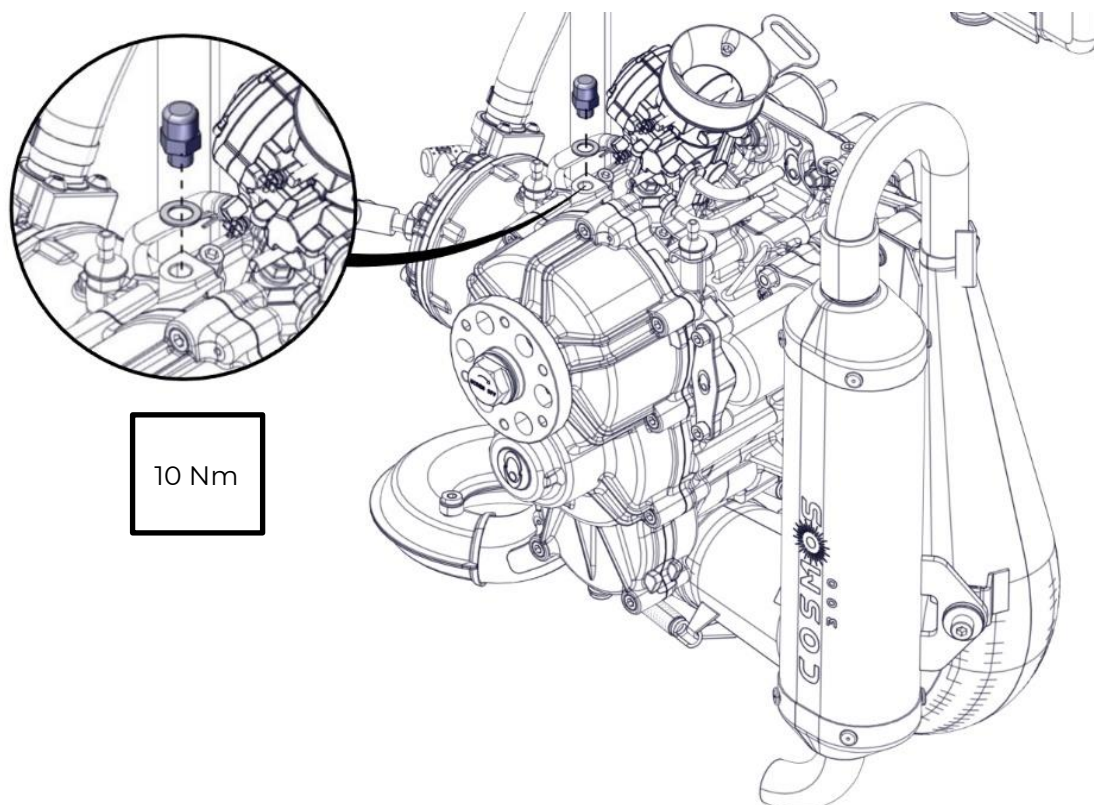

3.13.2 Transmission disassembly



Before disassembling the transmission, remove the oil.

Remove the 9 Allen screws M6x30 (1) from the transmission cover (2).
Place the 2 set screws M4x30 (3) [ACCT111] into the position A and screw in alternately until the cover (2) is removed.
Remove the gasket (4).

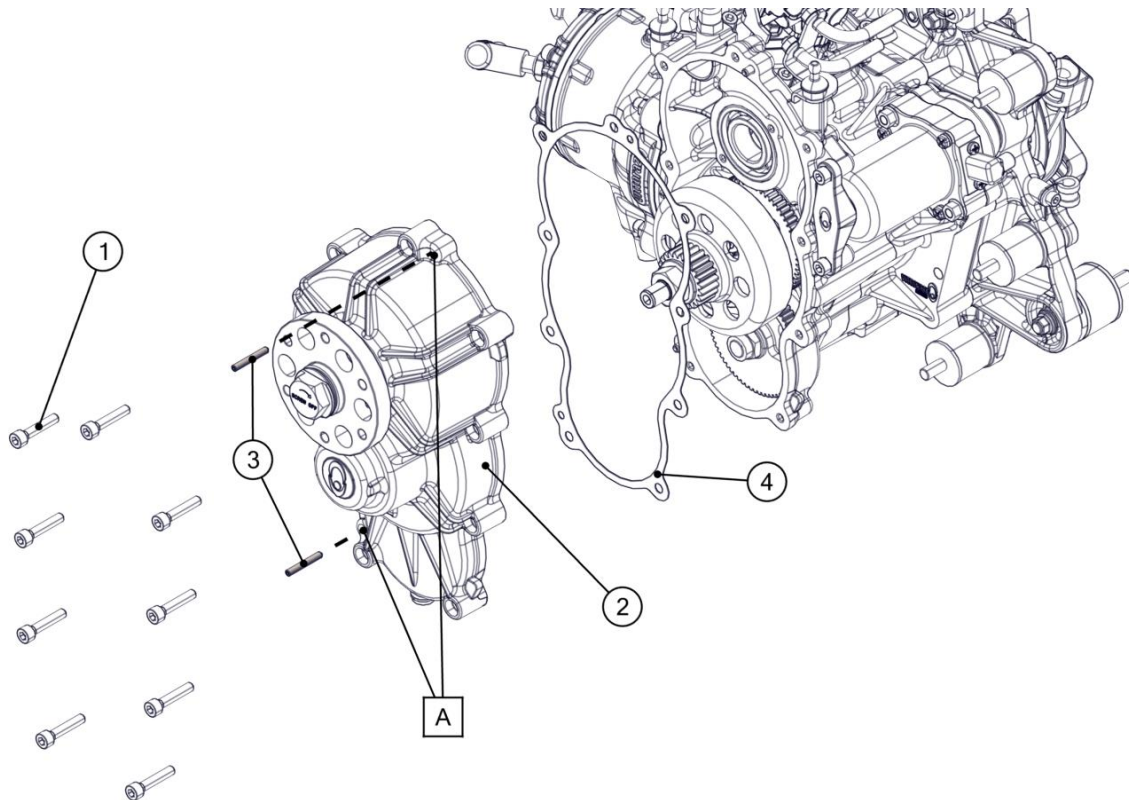

Turn the countershaft gear to position it as shown in the figure.

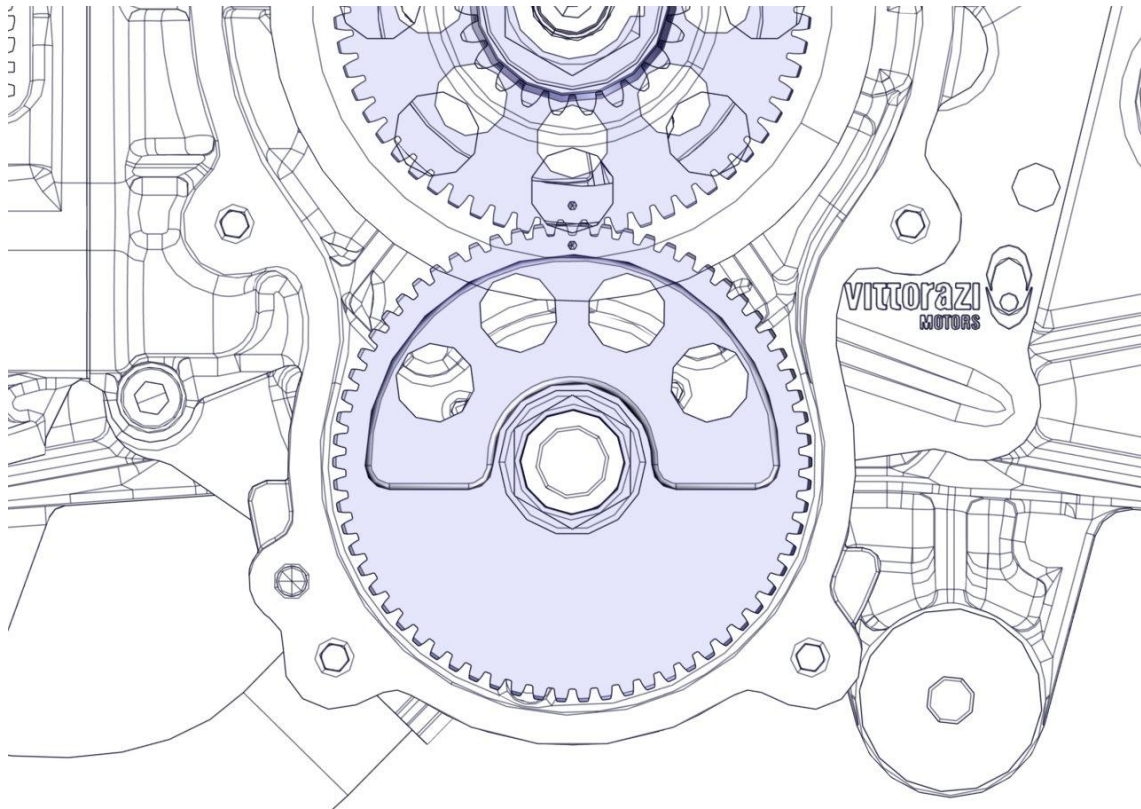

Insert the part A of the transmission locking tool into the holes of the 2 gearwheels.

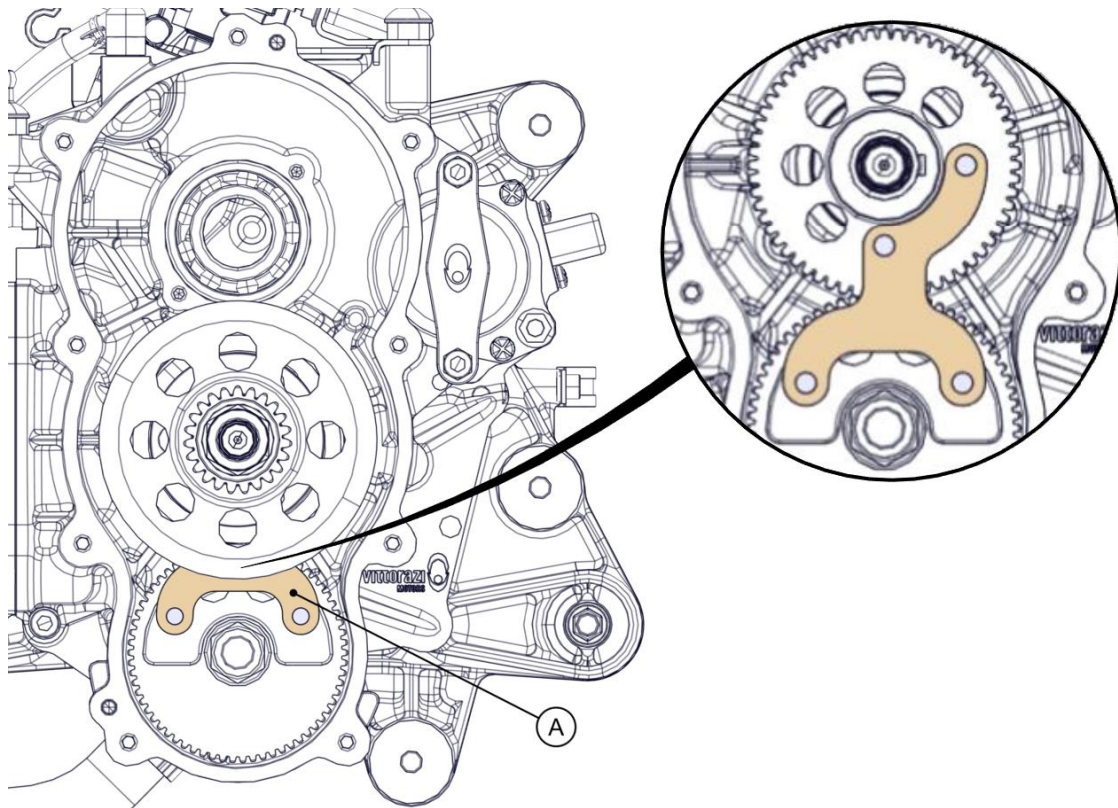

Insert the part B of the transmission locking tool [ACC112] as shown in the figure.
Secure the locking tool with the 2 Allen screws M6x20 (5).

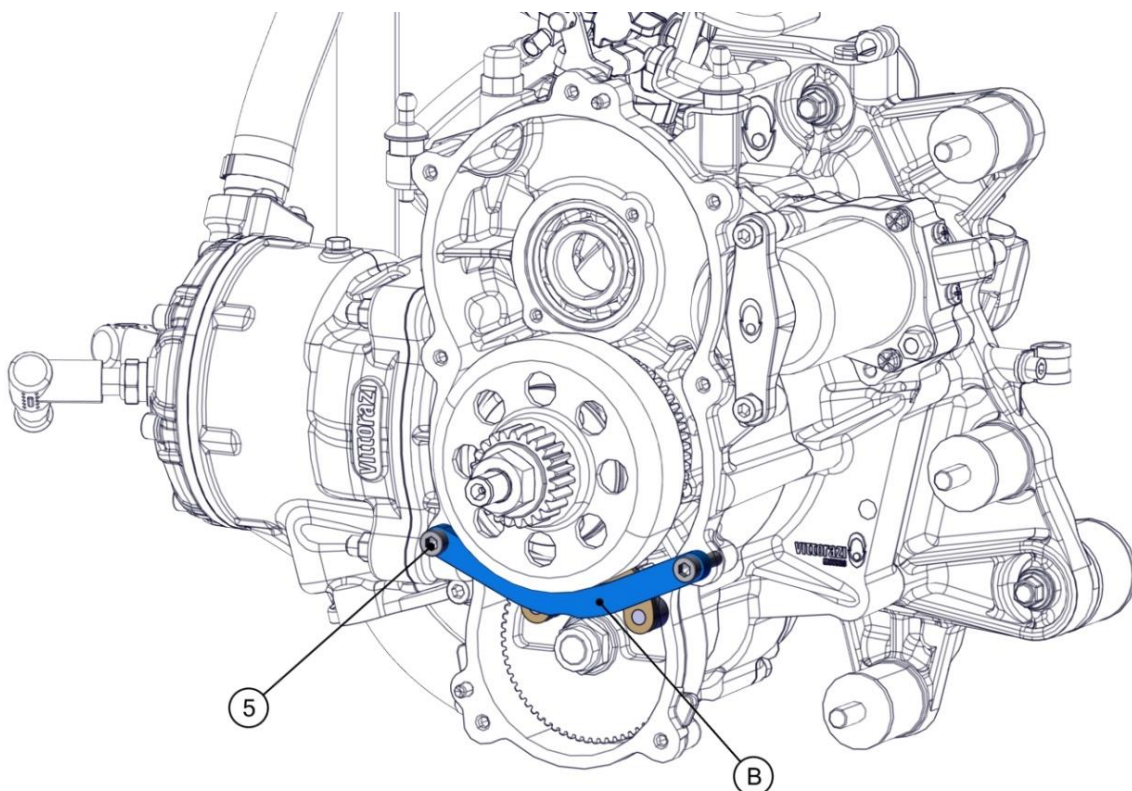

Remove the nut M14x1,5 (6) with the washer (7) from the crankshaft (10).
Remove the clutch bell (8).
Remove the 2 roller bearings (9).
Remove the bushing (11).

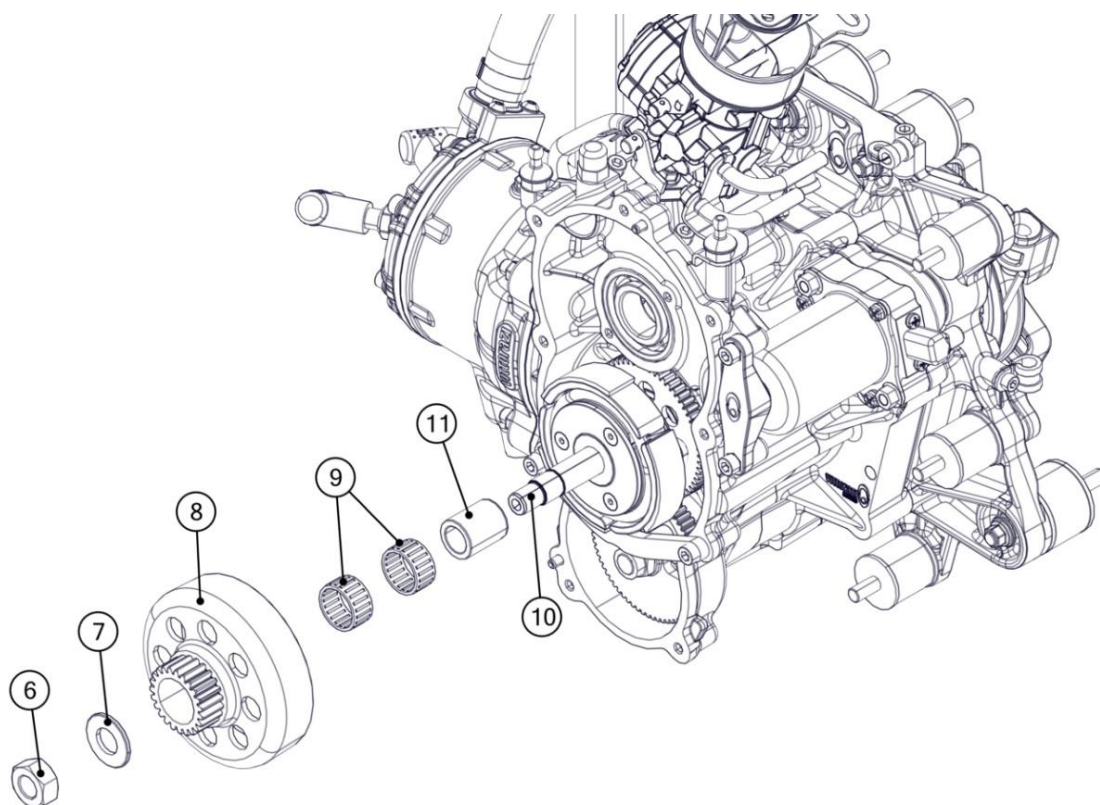



Do not remove the spring from the clutch.

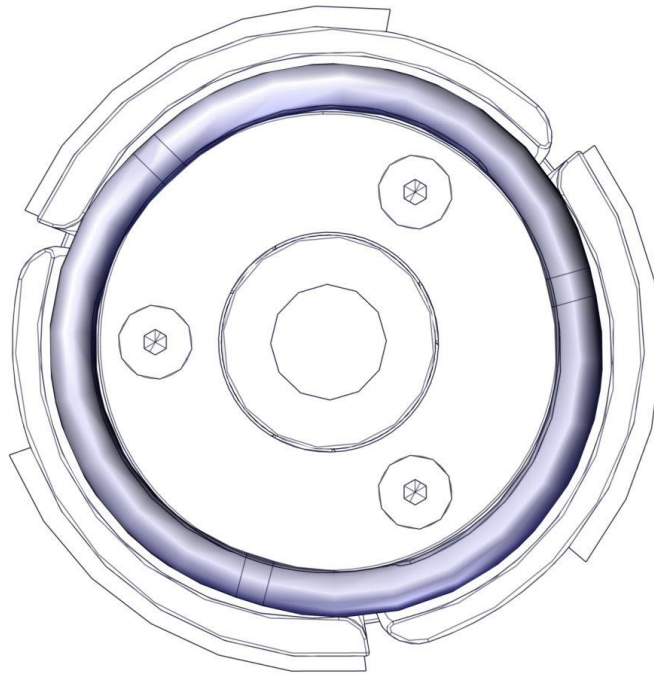

Remove the 3 Torx screws M5x14 (12) from the clutch (13).
Remove the clutch plate (14).

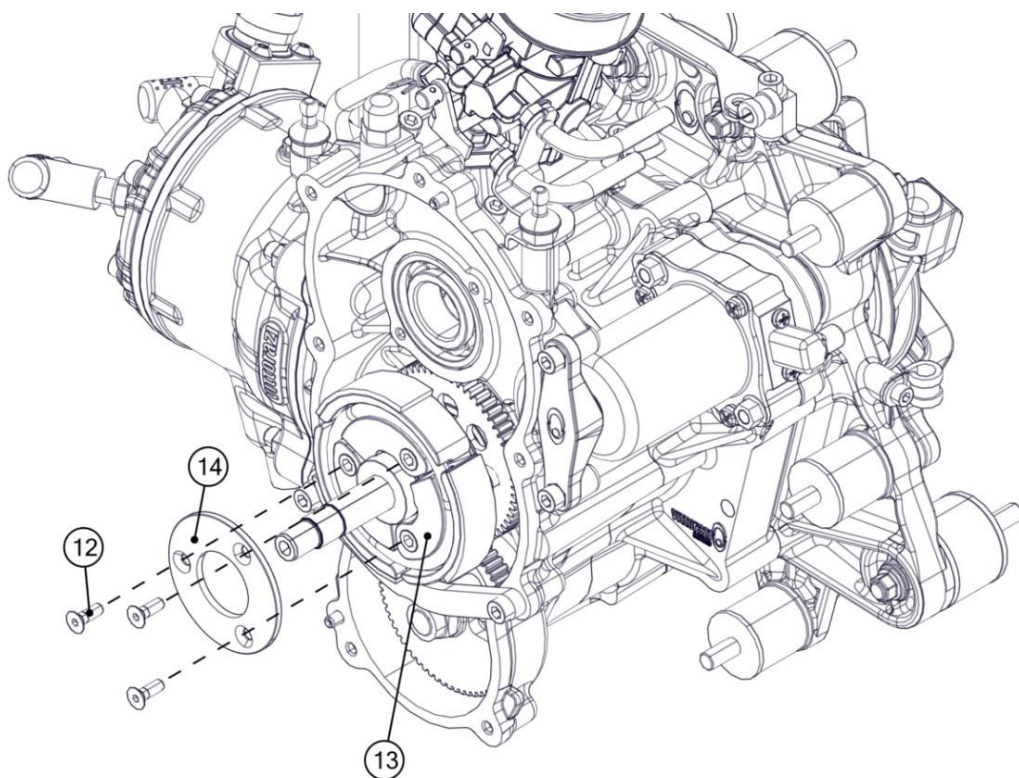

Position the extractor (15) [ACC113] on the clutch (13) and tighten the 3 screws M5x70 (16). Turn the central pin (17) until the clutch (13) is removed from the crankshaft.

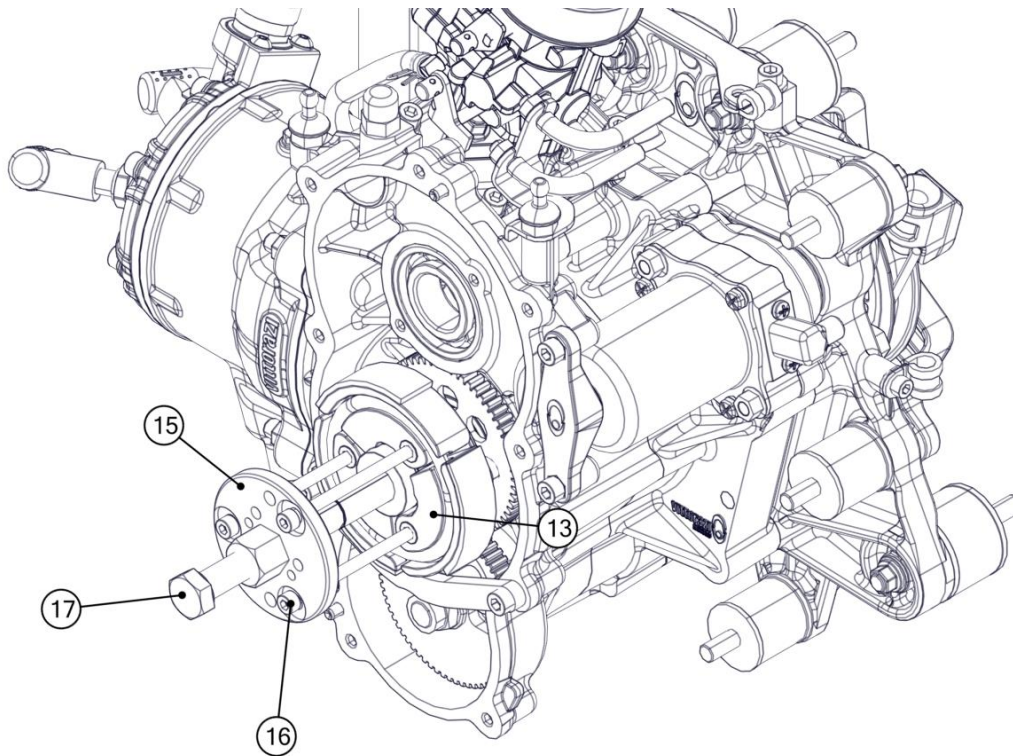

Remove the nut M12x1,25 (18) with the washer (19) from the countershaft (20).

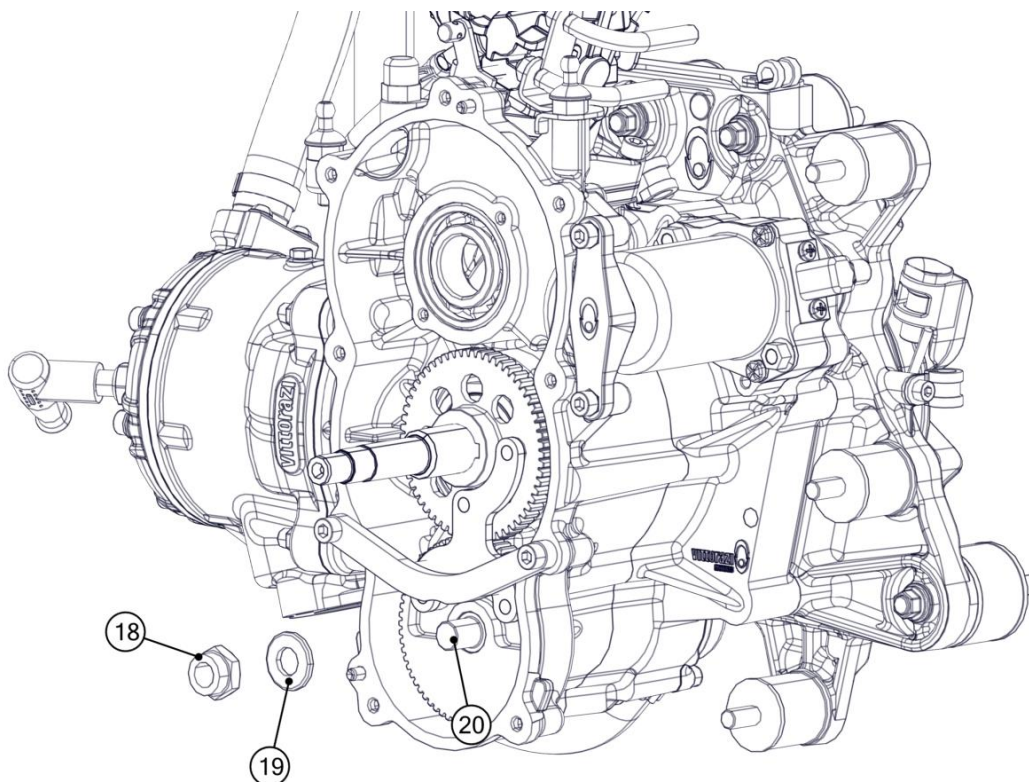

Remove the 2 Allen screws M6x20 (5).
Remove the part B.
Remove the part A.

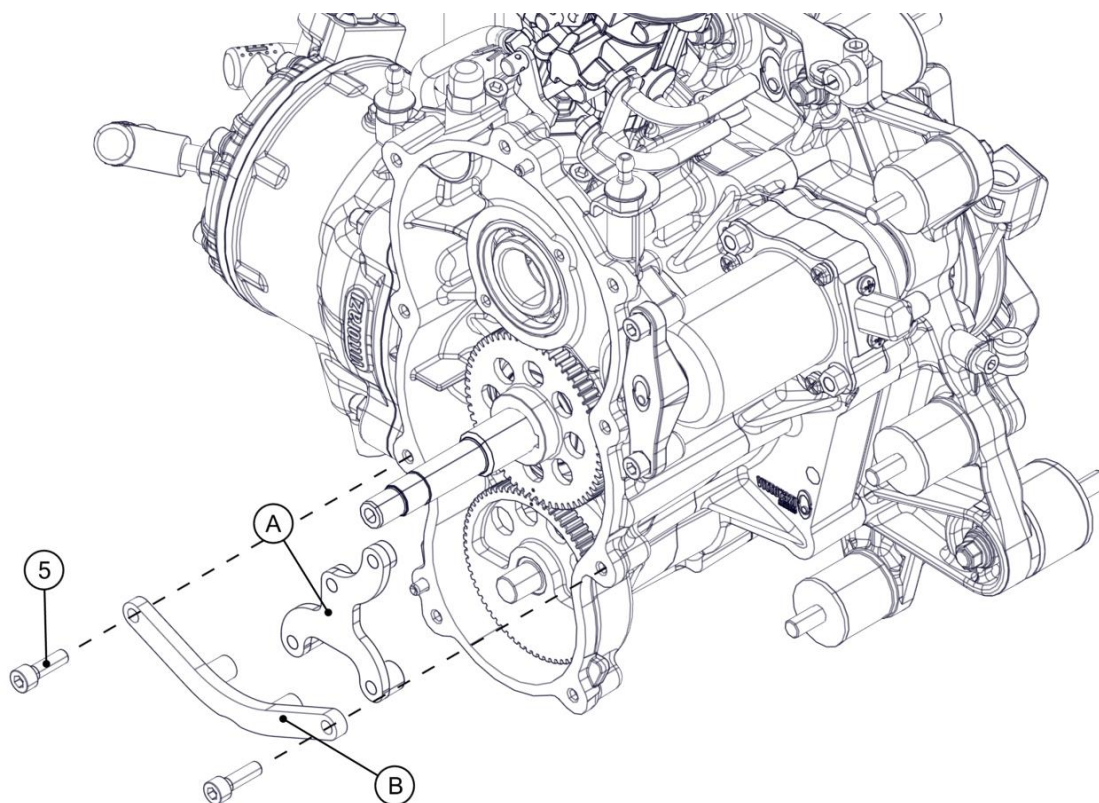

Remove the driven gear (21) from the countershaft (20).

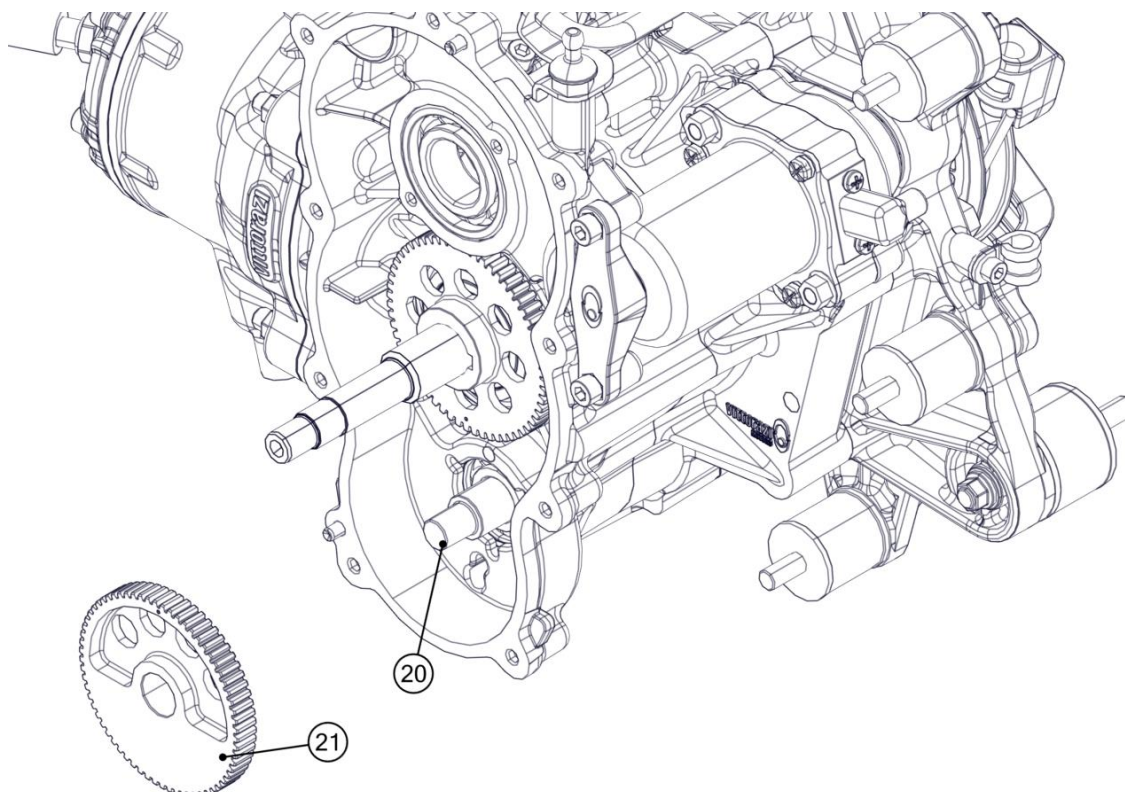

Remove the drive gear (22) from the crankshaft (10).

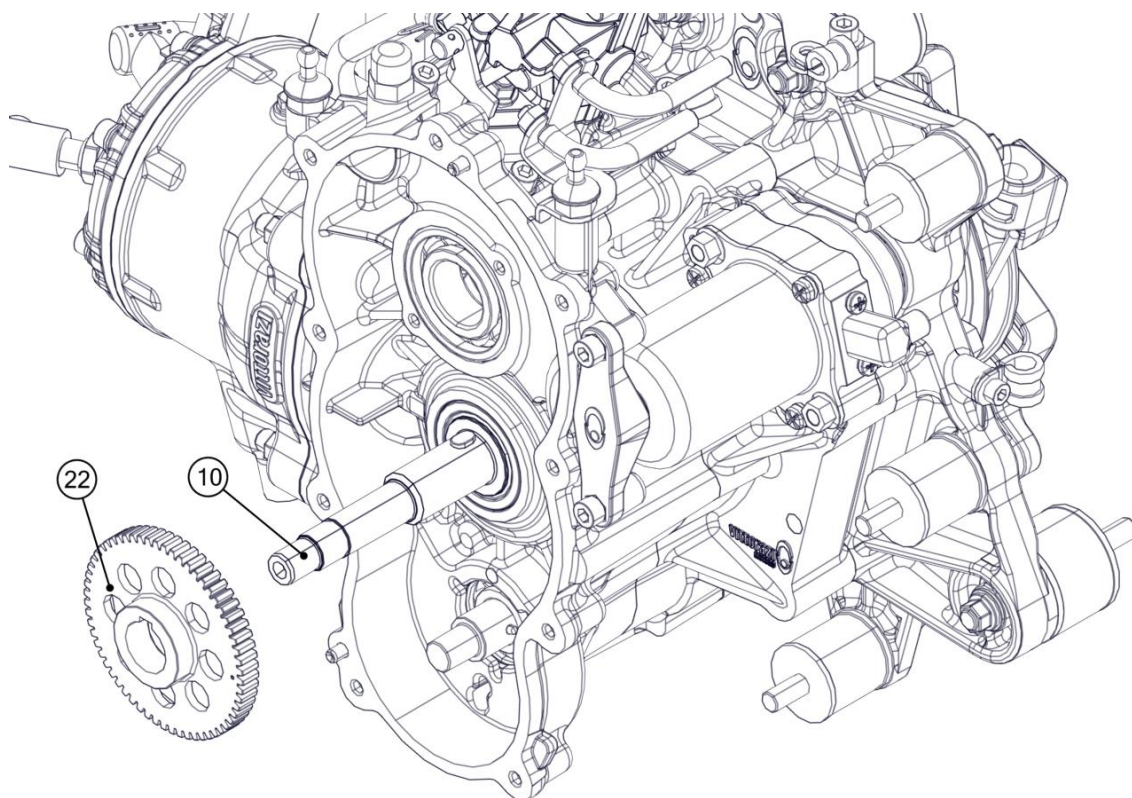

Check the condition of the key (23): remove it from the crankshaft (10) if damaged.

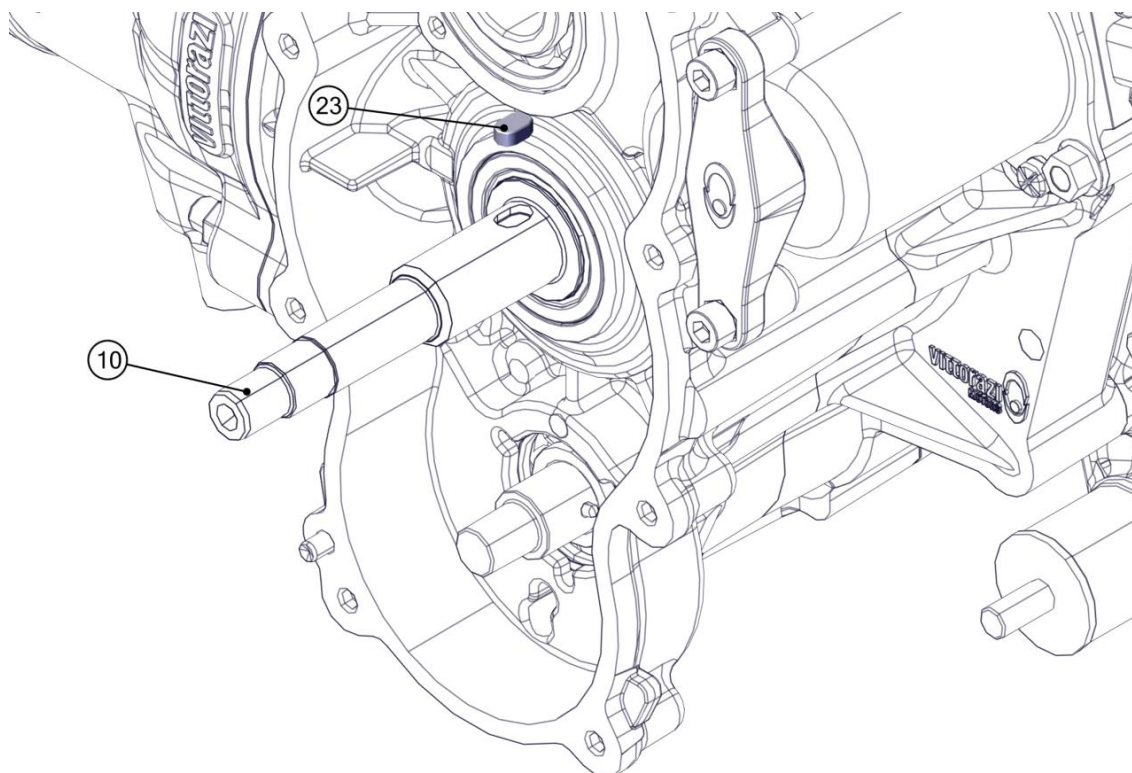

Heat the upper bearing seat to 120 °C and remove the bearing (24).

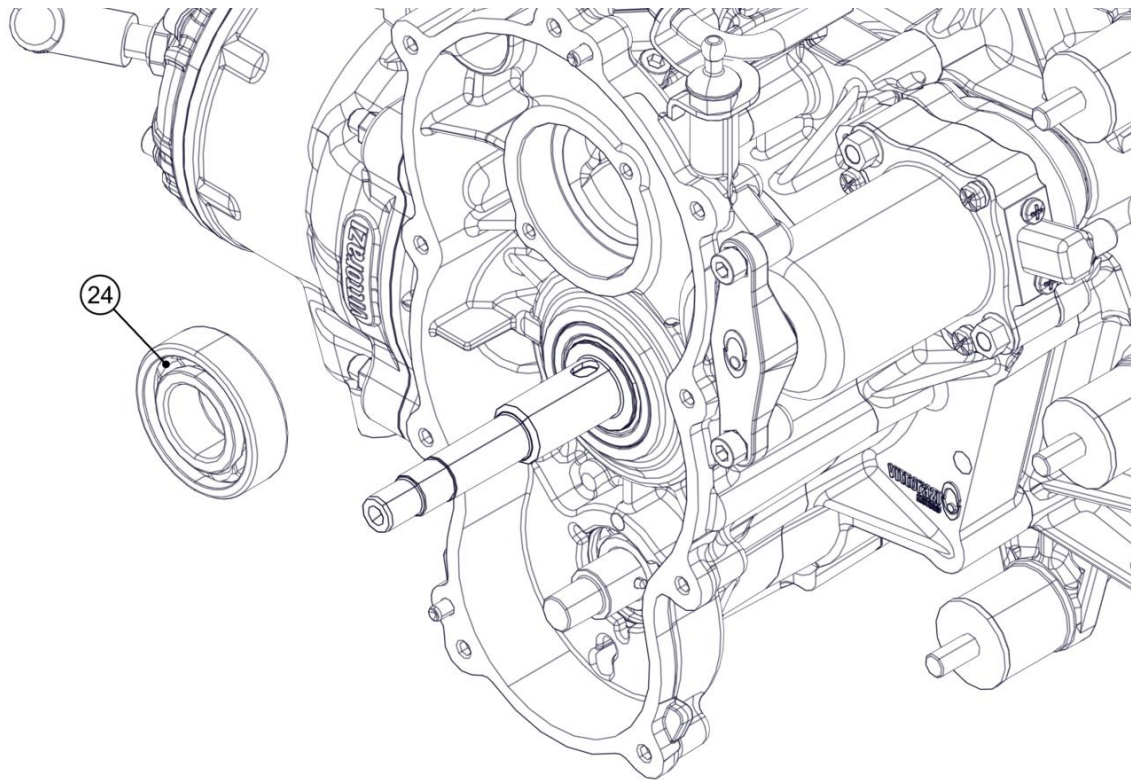

Unbend the anti-unscrewing washer (28).

Fix the propeller hub locking tool (25) [ACC110] on the hub (29) with 2 screws M8x25 (26).

Hold the end of the locking tool (25) and remove the left-handed screw M8 (27).

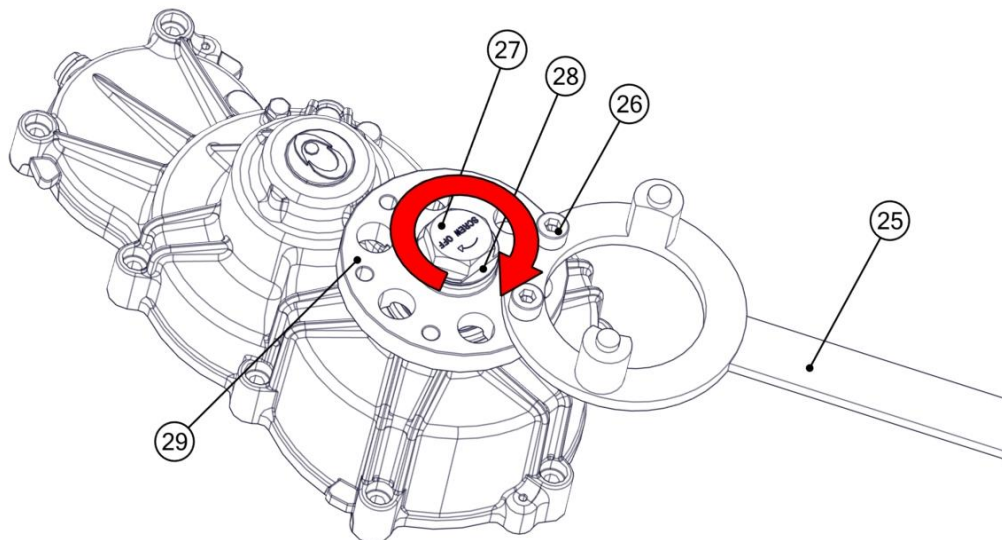

Remove the locking tool (25).

Remove the anti-unscrewing washer (28) and the propeller hub (29) from the propeller shaft (30).

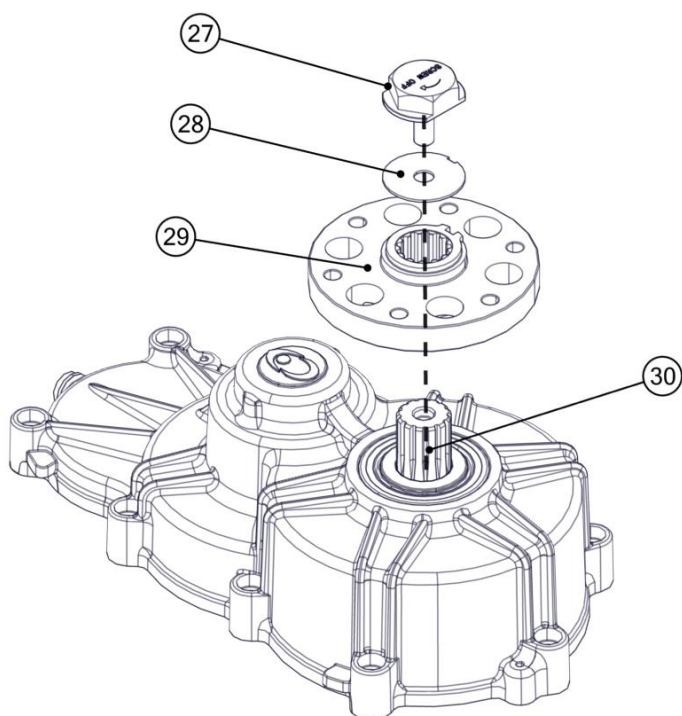

Remove the 2 flange head screws M4x8 (31).

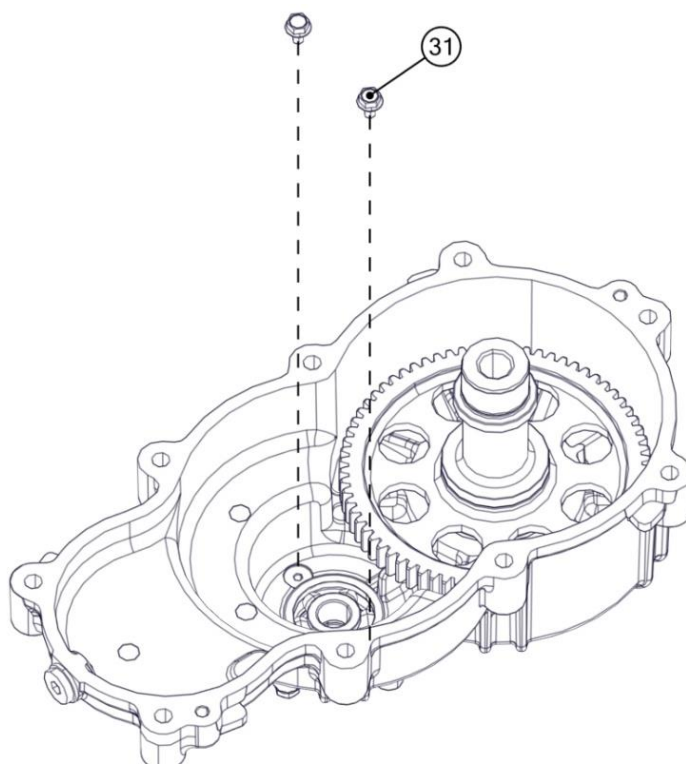

Heat the cover to 120 °C.

Remove the propeller shaft (30) with the bearing (32) and the bushing (33).

Remove the pinion bearing (34).

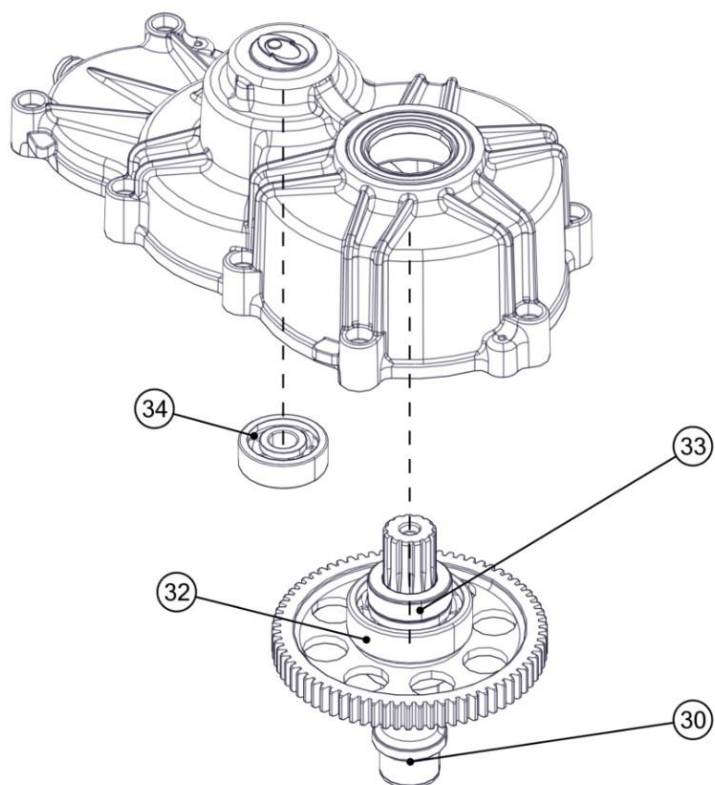

Remove the oil seal (35) from the transmission cover (2).

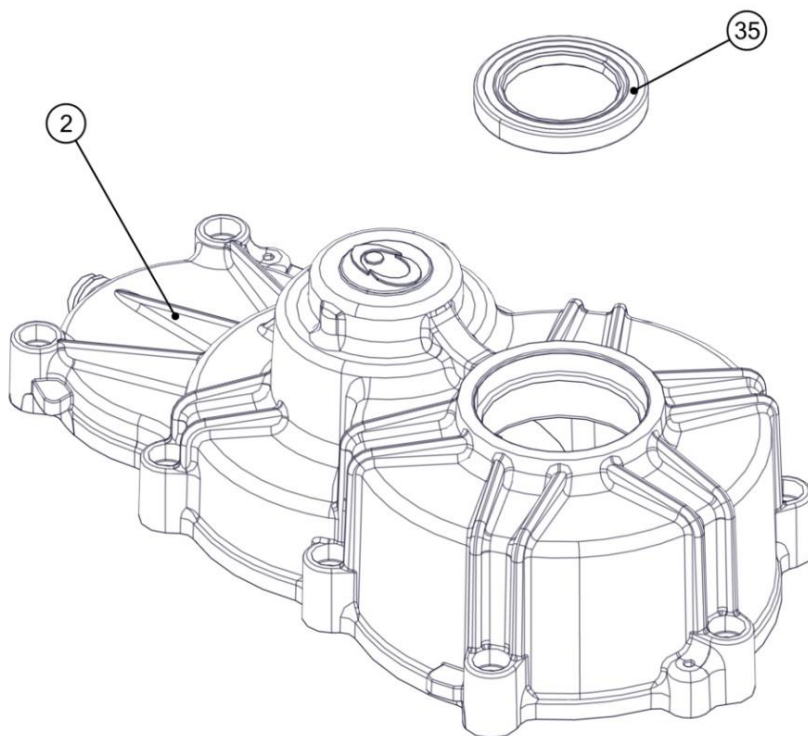

Remove the bushing (33) and the O-ring (36).
Remove the bearing (32) from the propeller shaft (30) using a bearing extractor.

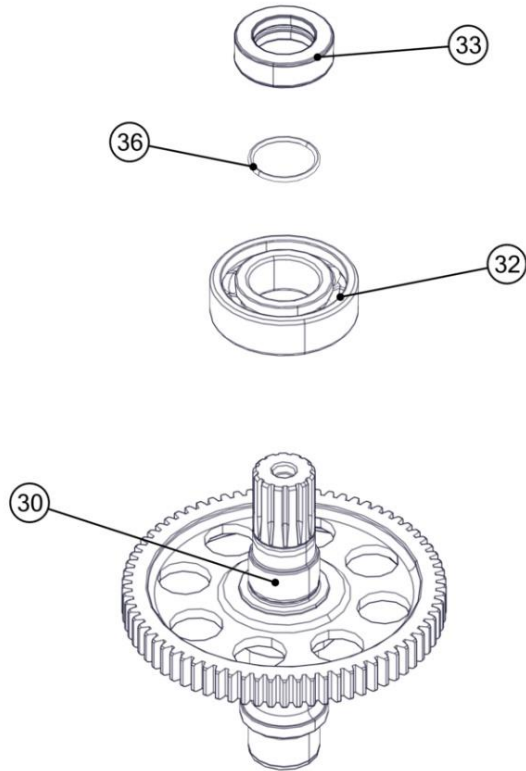

To remove the compensating ring (37) from the clutch (13) insert a pair of long nose pliers into the clutch groove.

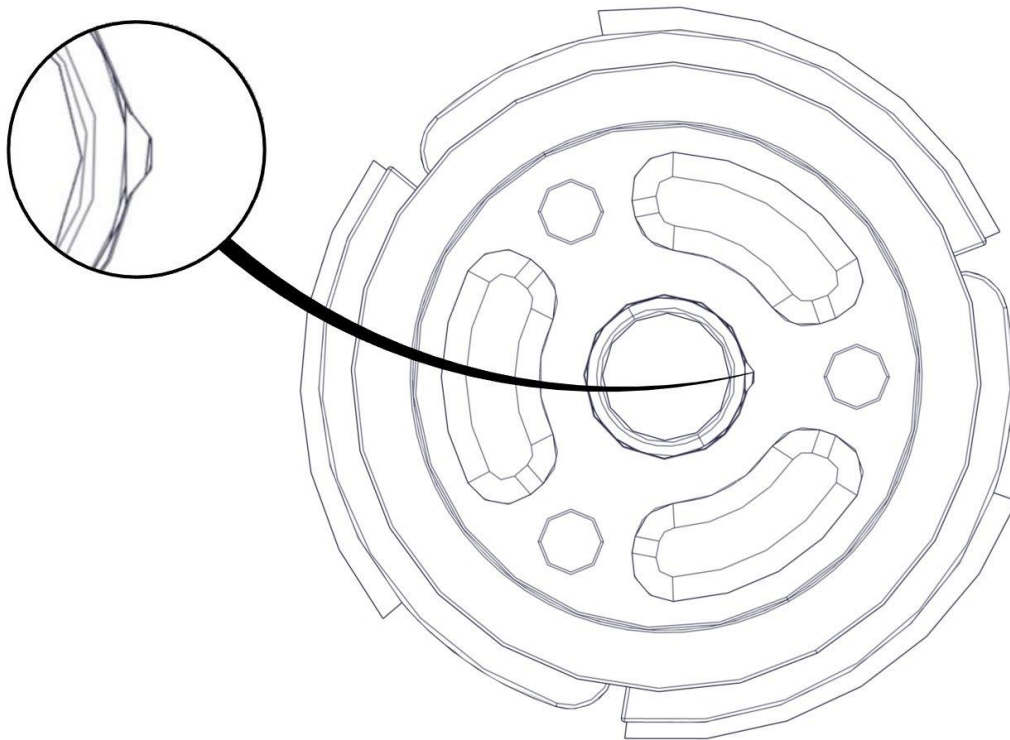

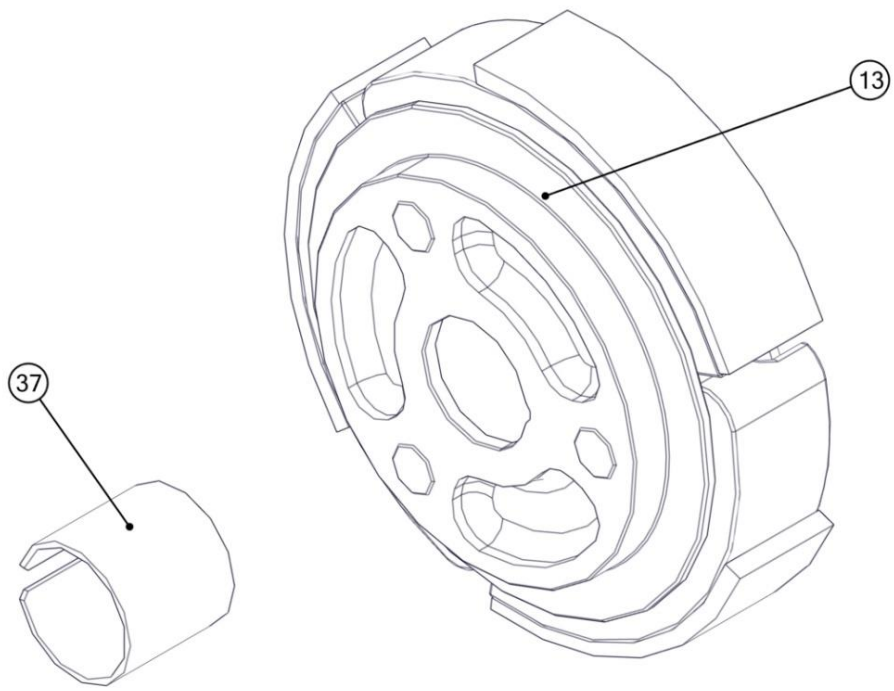

3.13.3 Transmission disassembly – ULM model



Before disassembling the transmission, remove the oil.

Remove the 9 Allen screws M6x30 (1) from the transmission cover (2).
Place the 2 set screws M4x30 (3) [ACC111] into the position A and screw in alternately until the cover (2) is removed.
Remove the gasket (4).

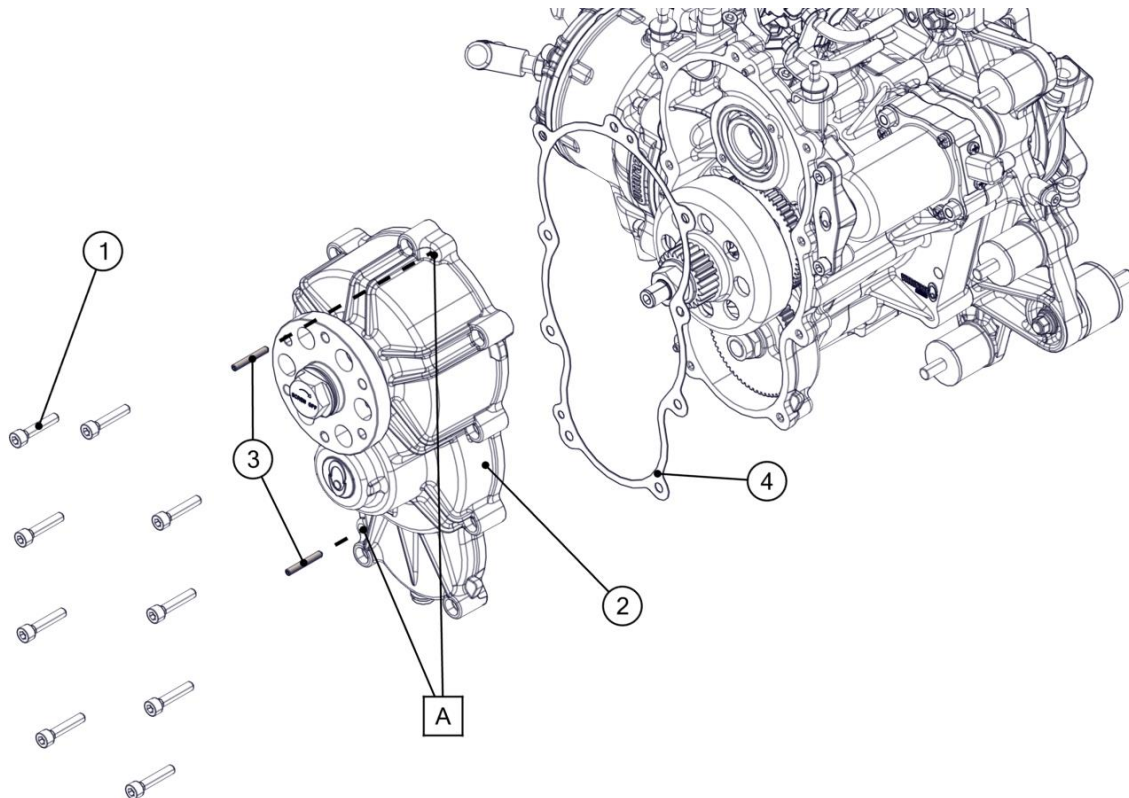

Turn the countershaft gear to position it as shown in the figure.

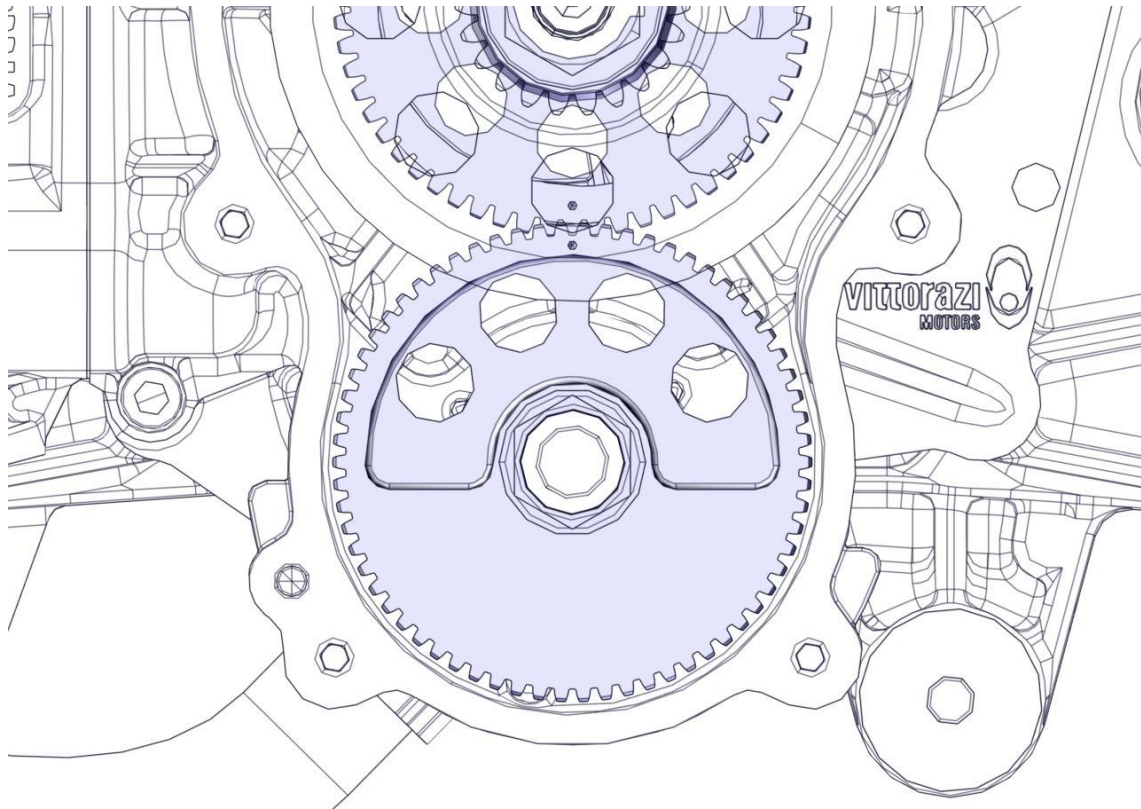

Insert the part A of the transmission locking tool into the holes of the 2 gearwheels.

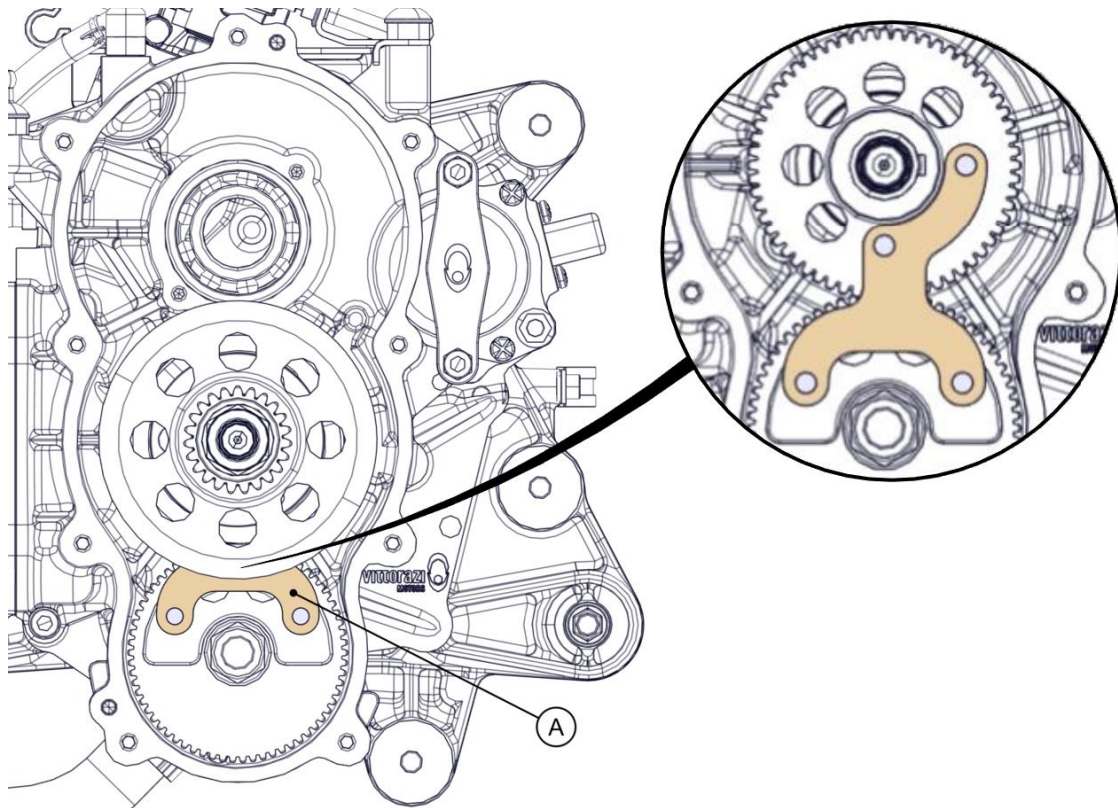

Insert the part B of the transmission locking tool [ACC112] as shown in the figure.
Secure the locking tool with the 2 Allen screws M6x20 (5).

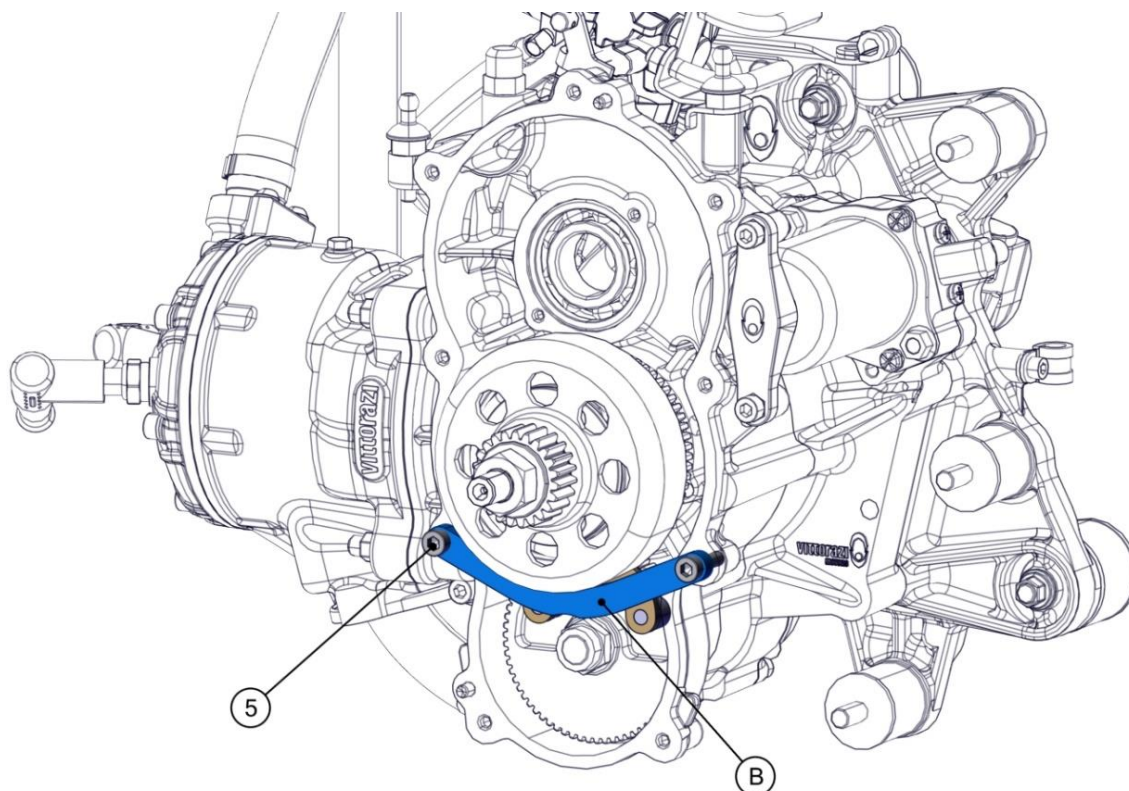

Remove the nut M14x1,5 (6) with the washer (7) from the crankshaft (10).
Remove the clutch bell (8).
Remove the 2 roller bearings (9).
Remove the bushing (11).

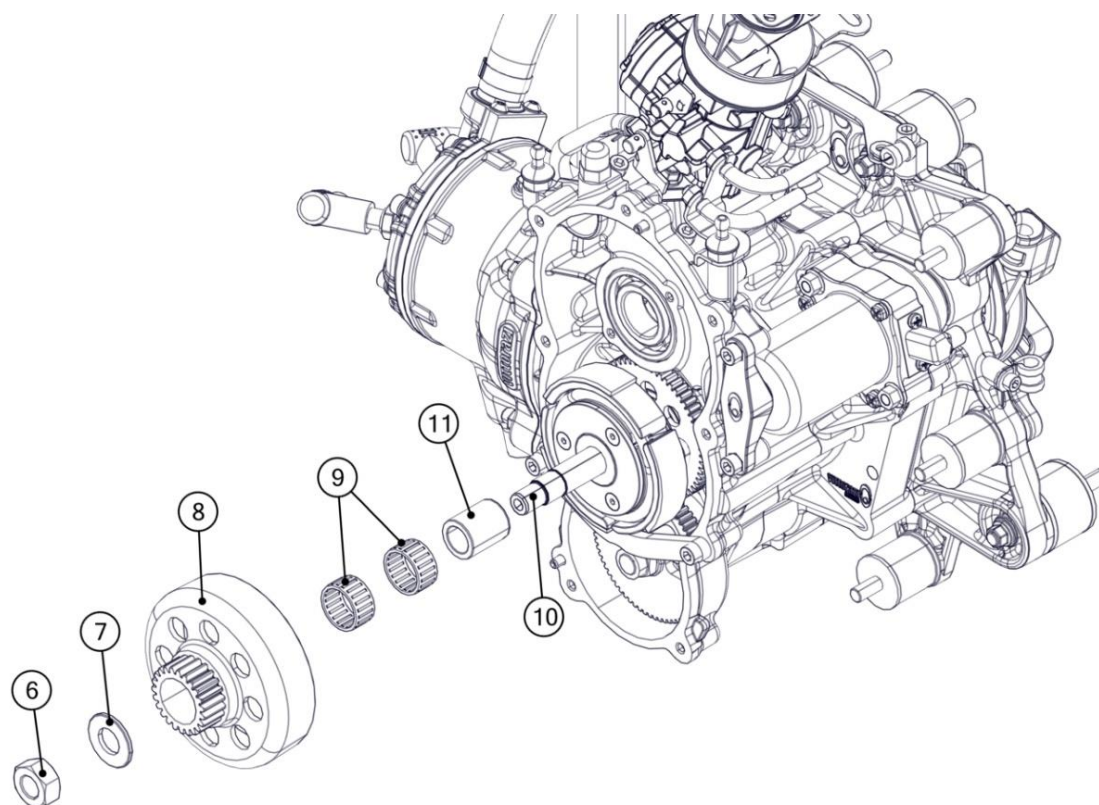



Do not remove the spring from the clutch.

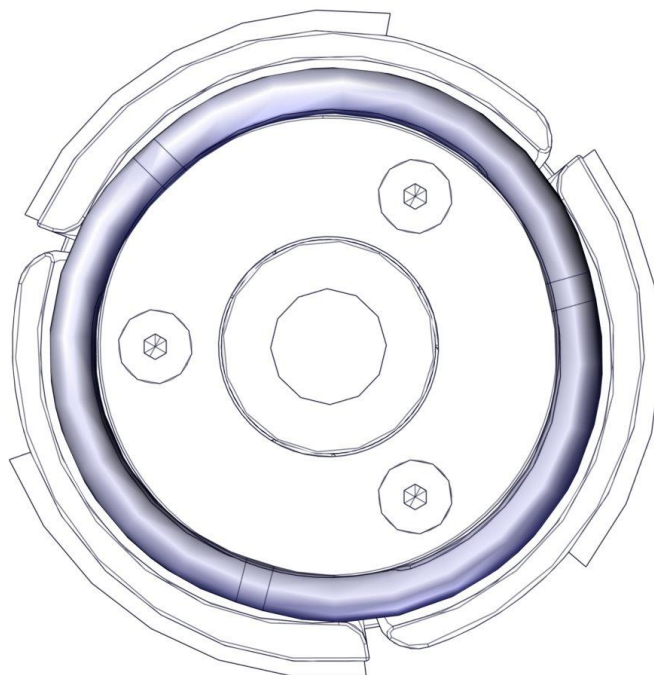

Remove the 3 Torx screws M5x14 (12) from the clutch (13).
Remove the clutch plate (14).

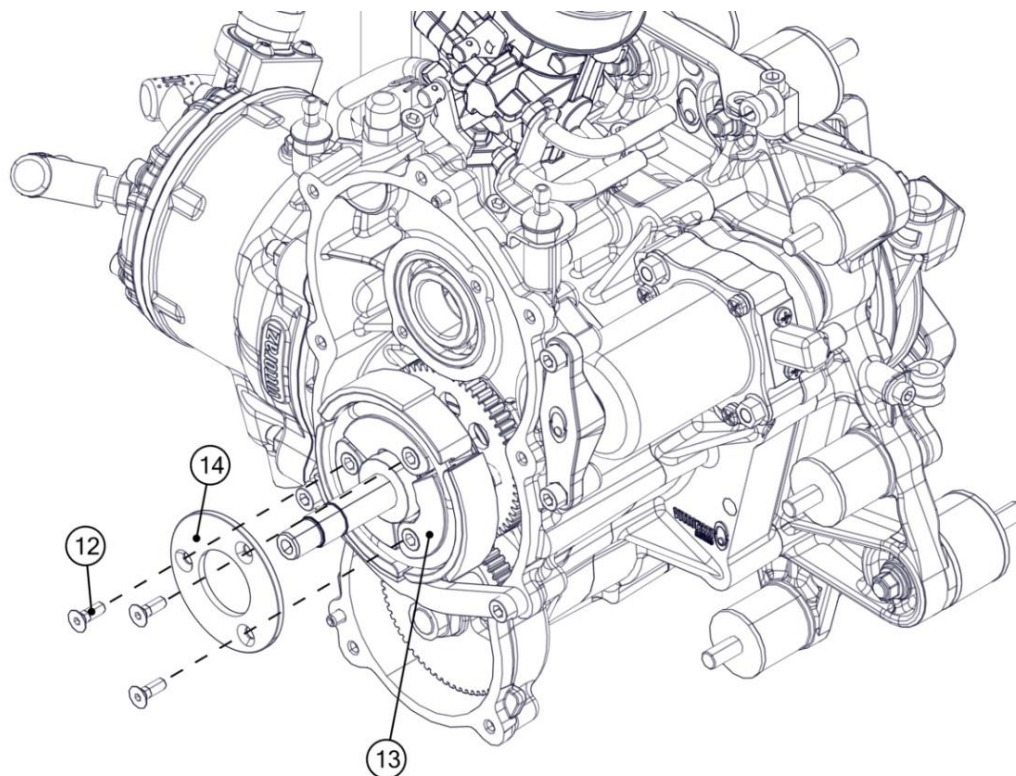

Position the extractor (15) [ACC113] on the clutch (13) and tighten the 3 screws M5x70 (16). Turn the central pin (17) until the clutch (13) is removed from the crankshaft.

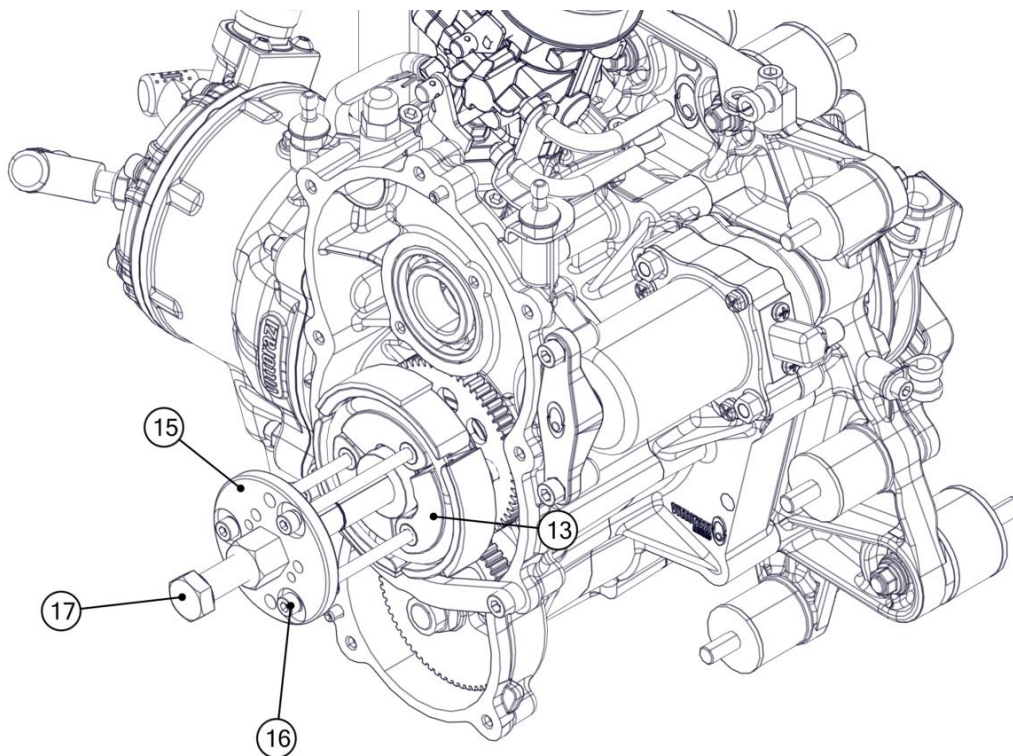

Remove the nut M12x1,25 (18) with the washer (19) from the countershaft (20).

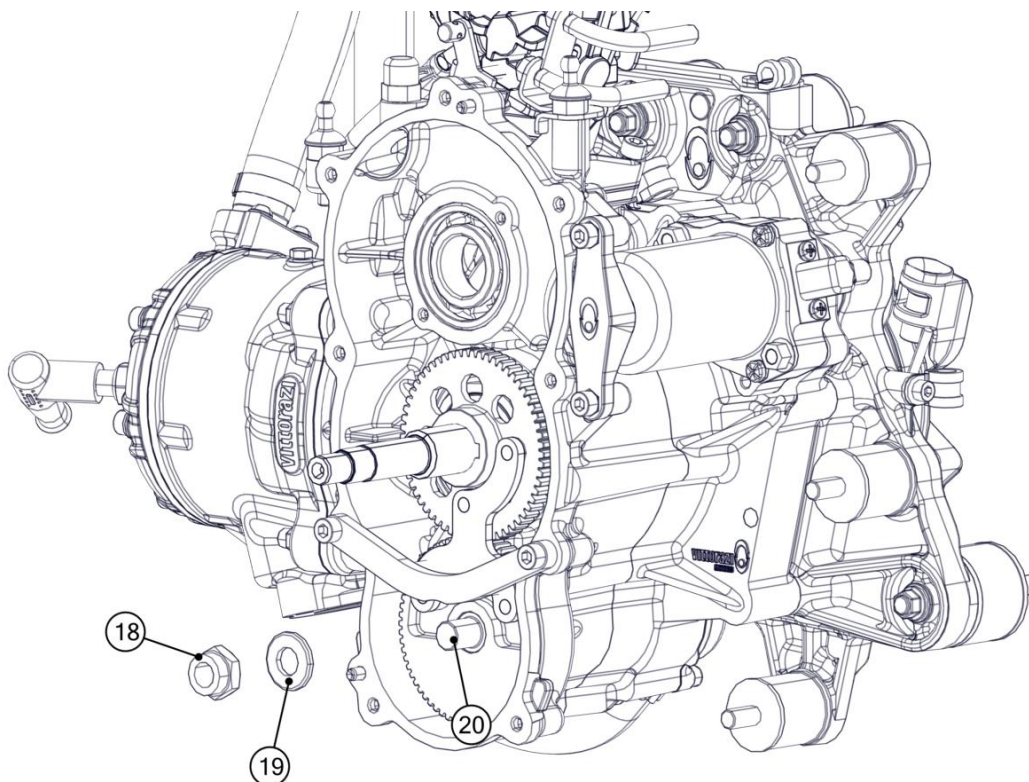

Remove the 2 Allen screws M6x20 (5).
Remove the part B.
Remove the part A.

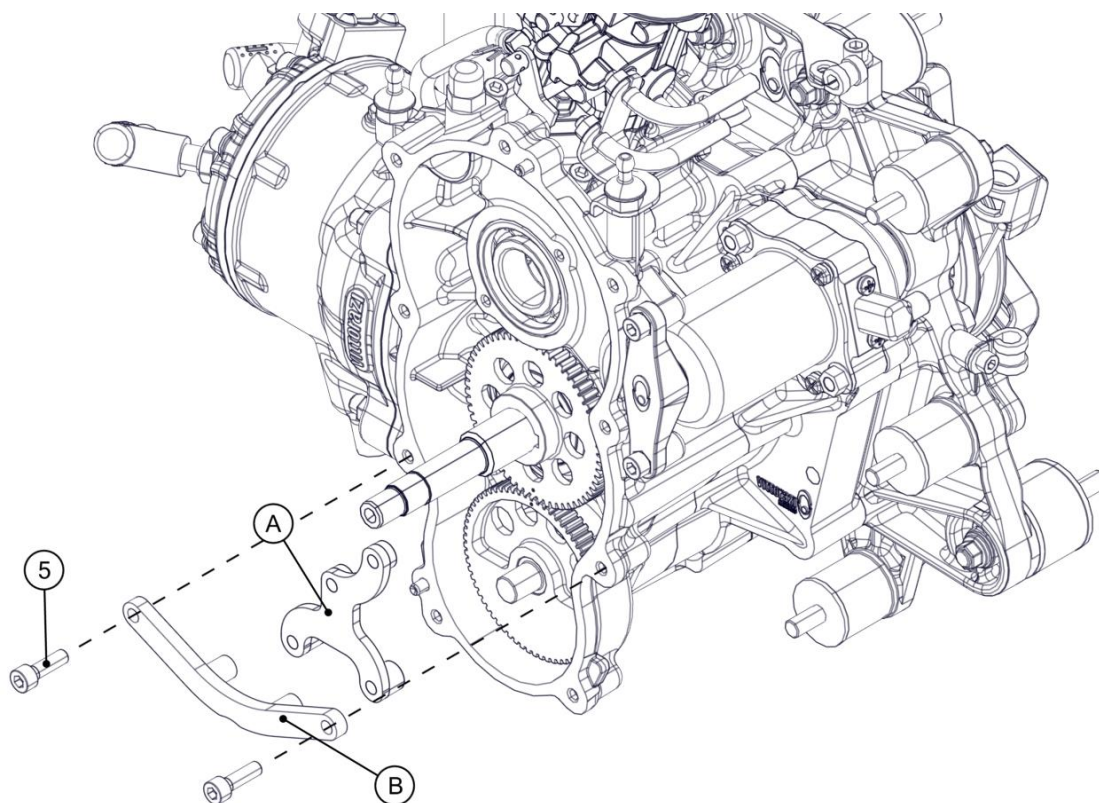

Remove the driven gear (21) from the countershaft (20).

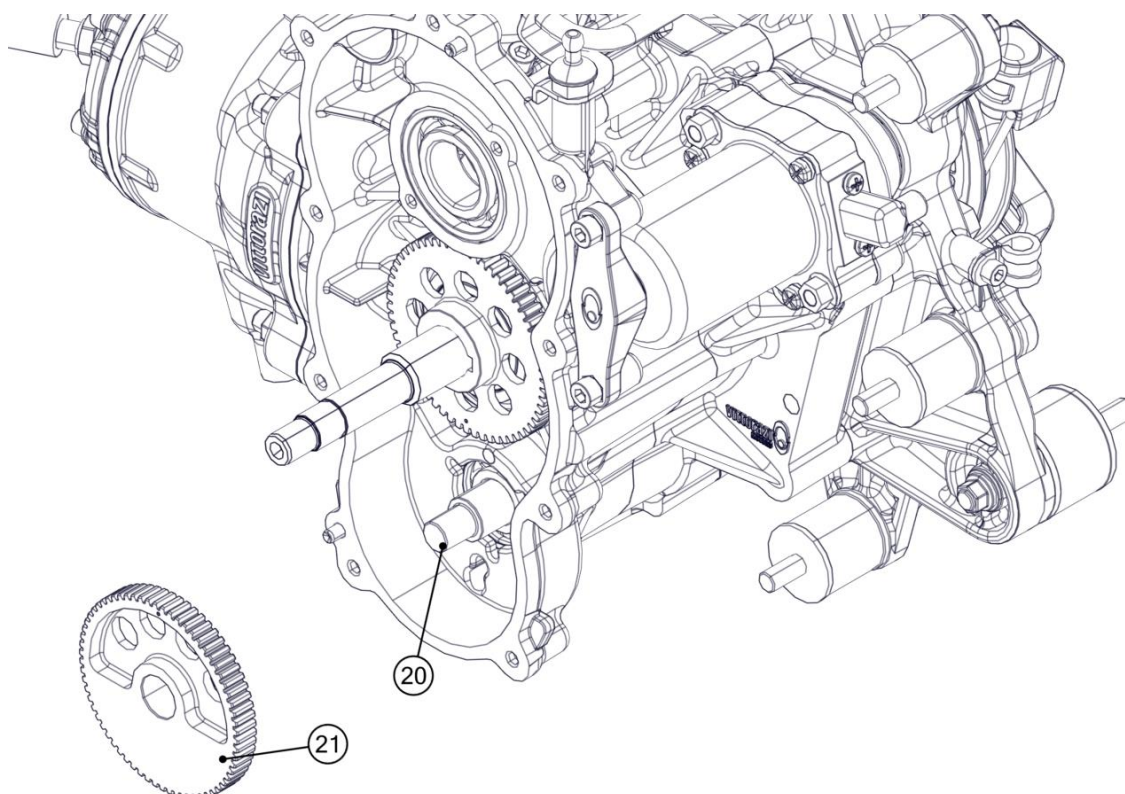

Remove the drive gear (22) from the crankshaft (10).

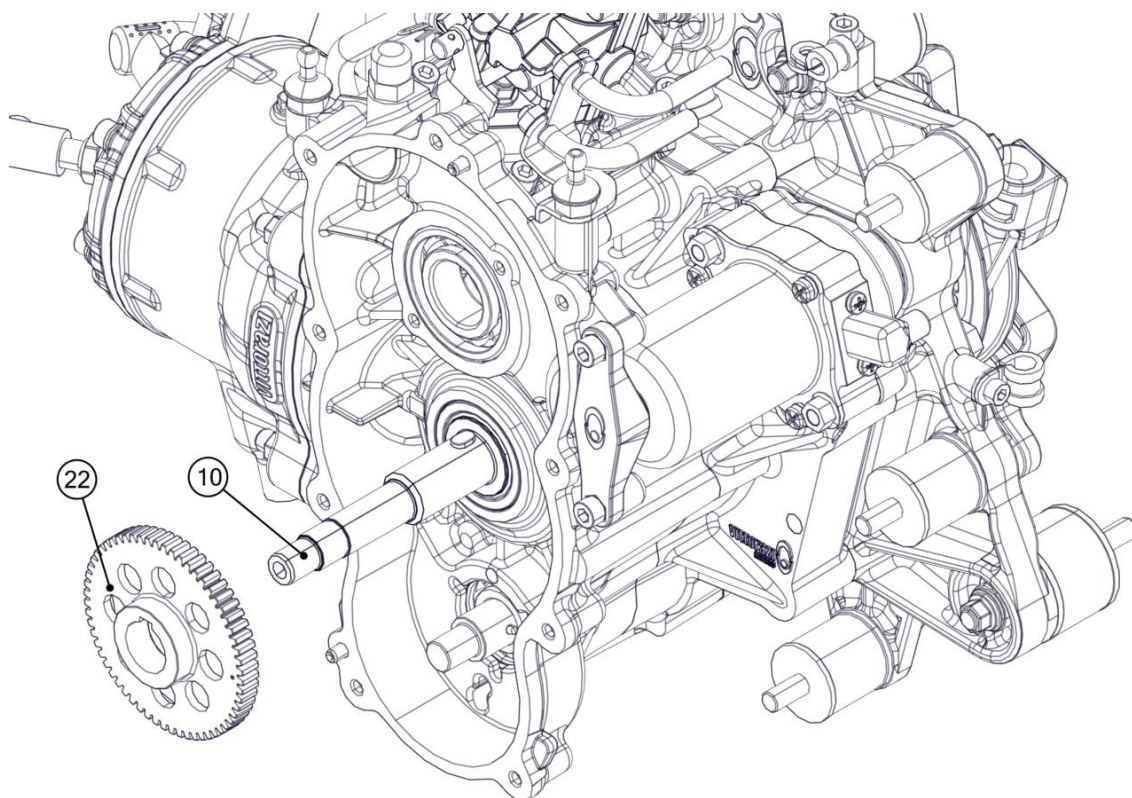

Check the condition of the key (23): remove it from the crankshaft (10) if damaged.

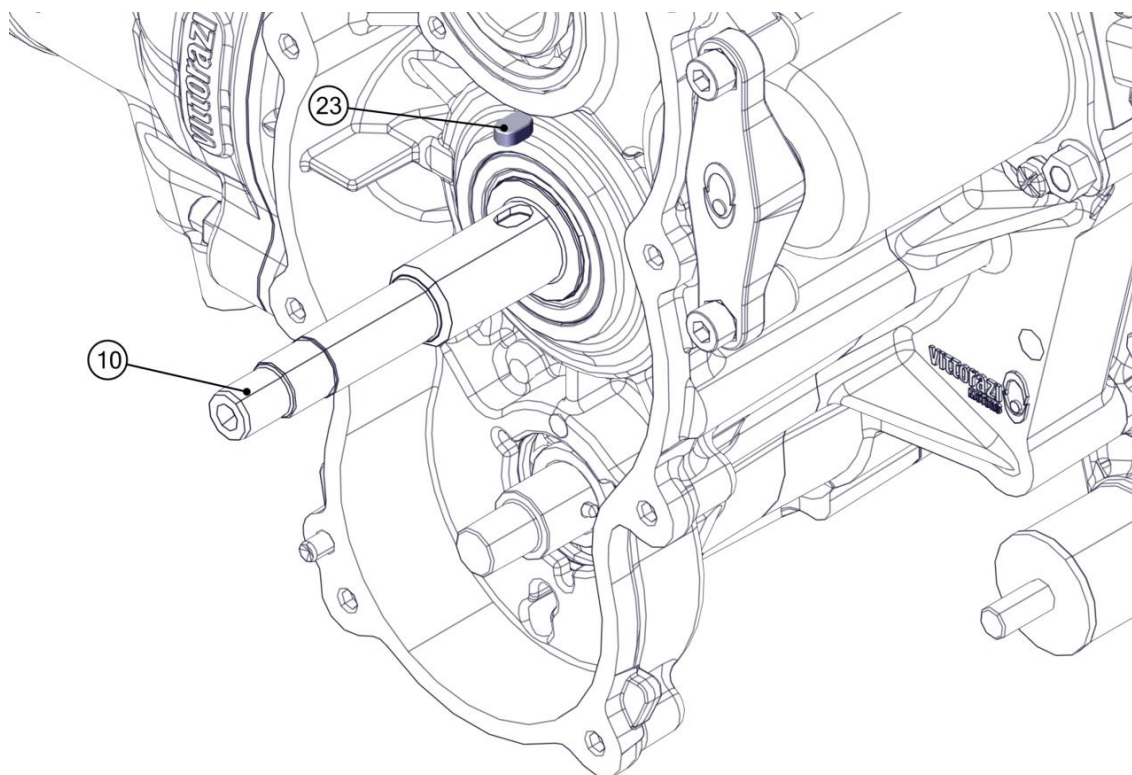

Heat the upper bearing seat to 120 °C and remove the bearing (24).

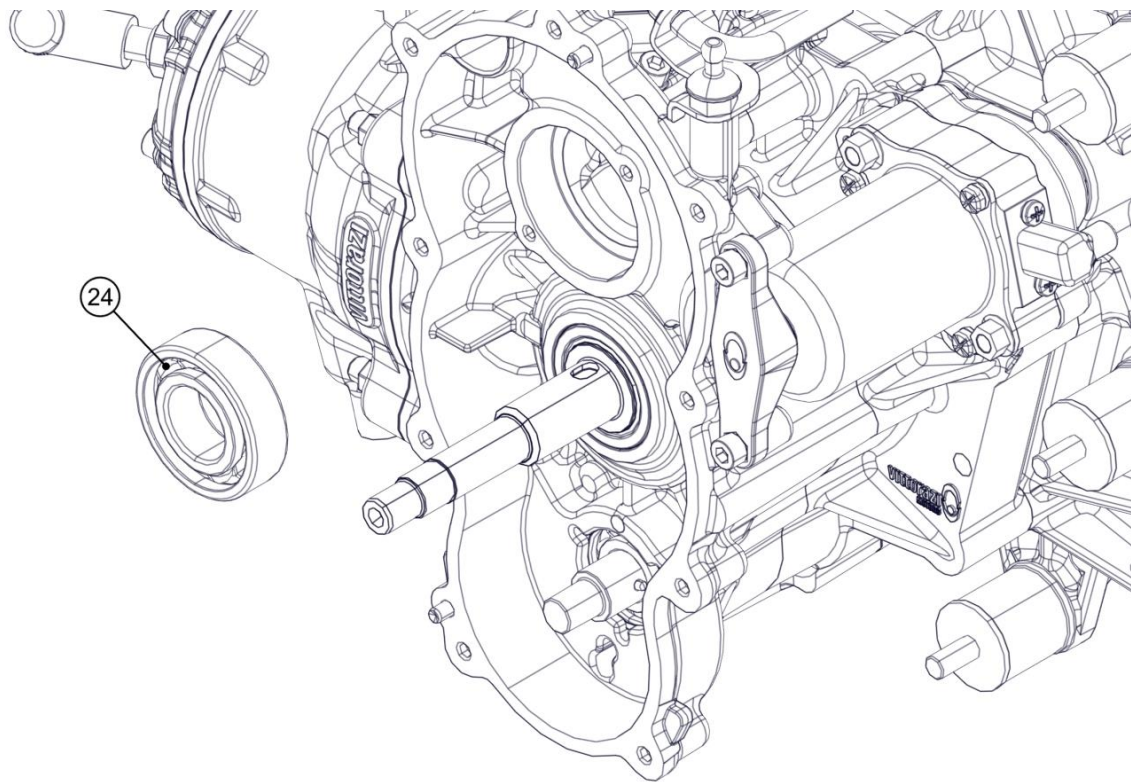

Unbend the anti-unscrewing washer (28).

Fix the propeller hub locking tool (25) [ACC110] on the hub (29) with 2 screws M8x25 (26).

Hold the end of the hub locking tool (25) and remove the left-handed screw M8 (27) and the anti-unscrewing washer (28).

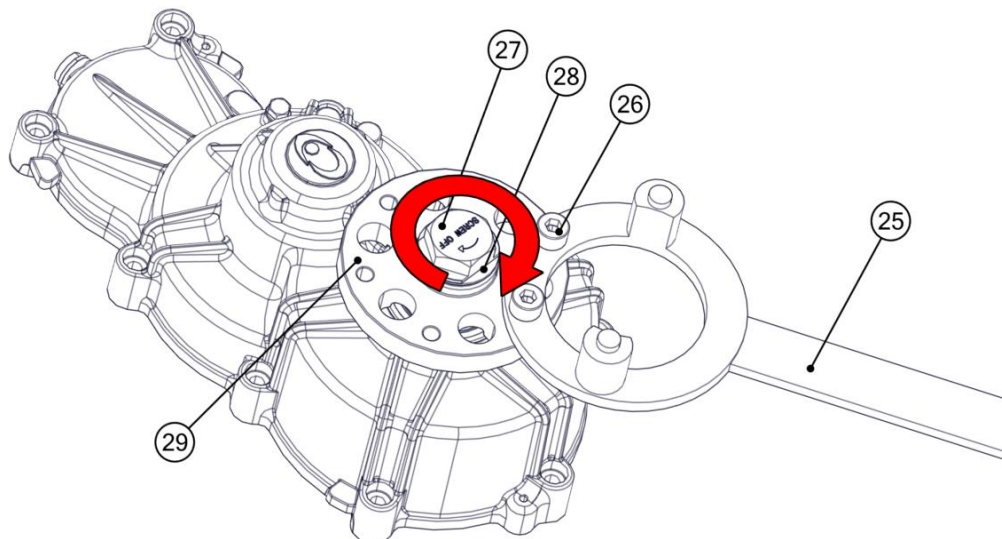

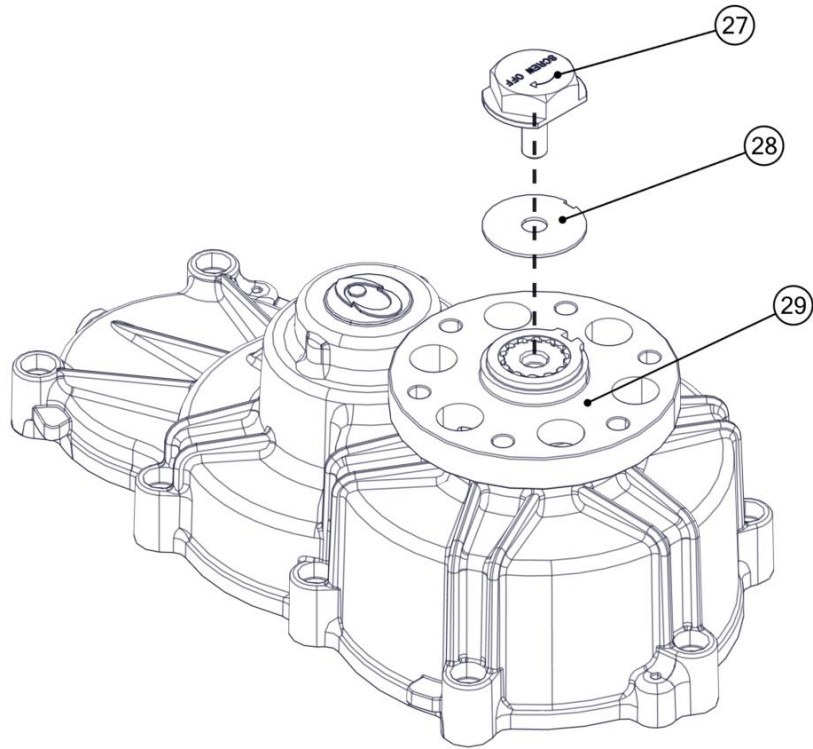

Remove the hub locking tool (25)
Heat the propeller hub (29) to 200 °C.
Position the extractor on the propeller hub (29) and tighten the 2 screws M5.
Turn the central pin until the propeller hub (29) is removed from the propeller shaft (30).

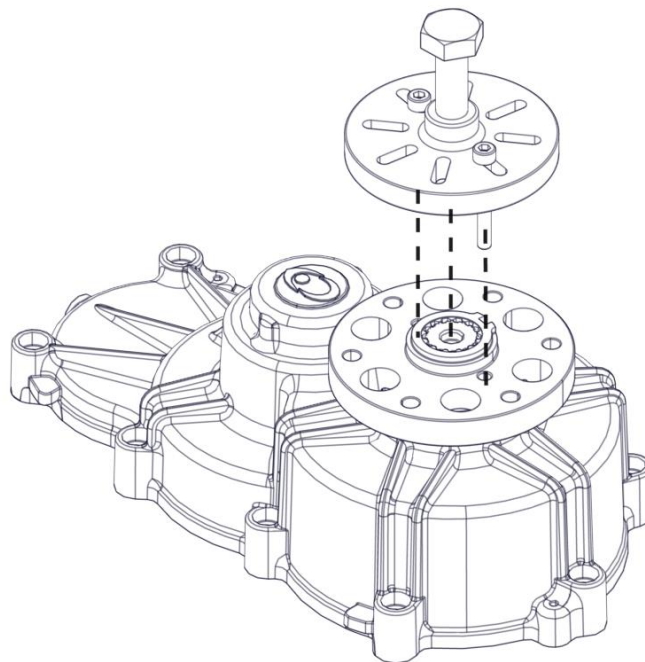

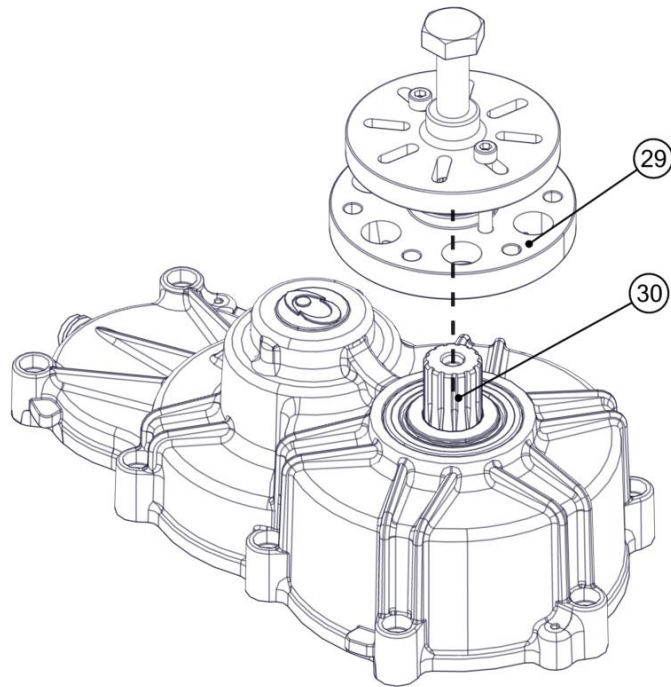

Remove the 2 flange head screws M4x8 (31).

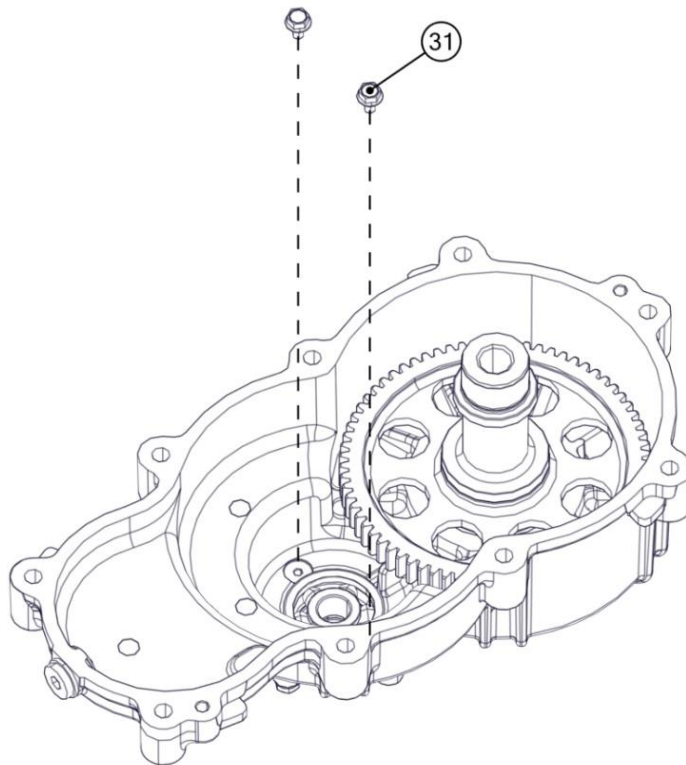

Heat the cover to 120 °C.

Remove the propeller shaft (30) with the bearing (32) and the bushing (33).

Remove the pinion bearing (34).

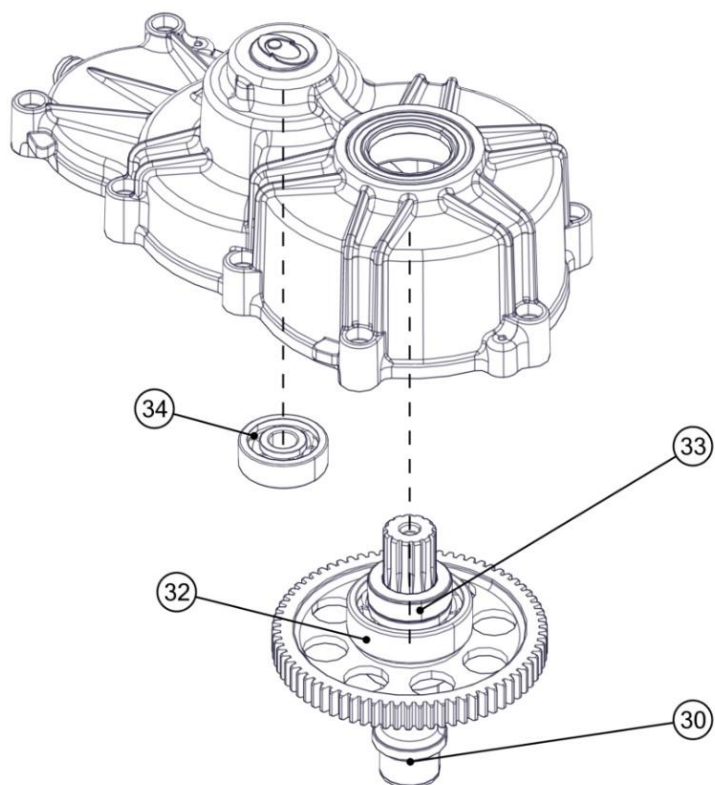

Remove the oil seal (35) from the transmission cover (2).

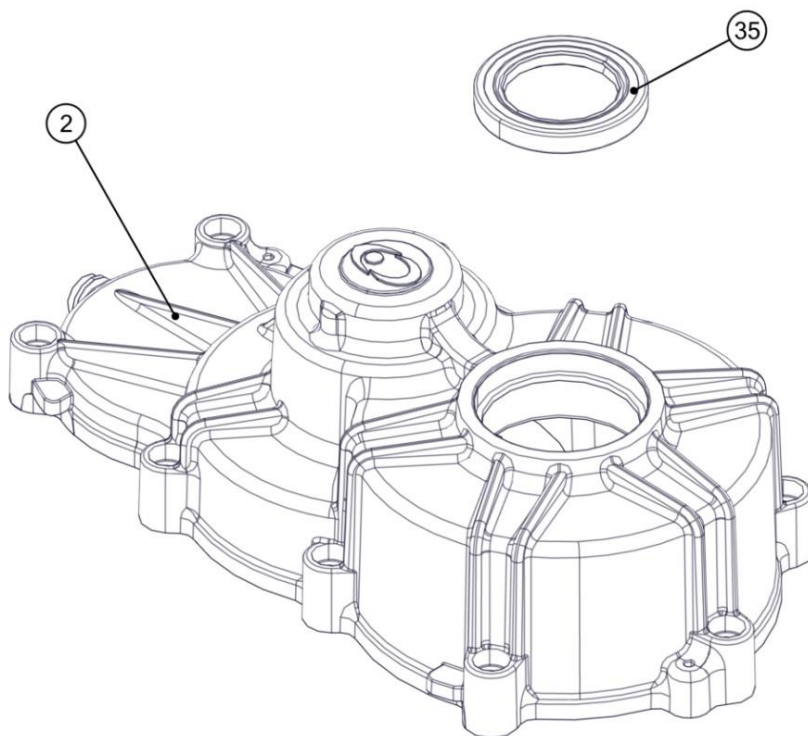

Remove the bushing (33) and the O-ring (36).
Remove the bearing (32) from the propeller shaft (30) using a bearing extractor.

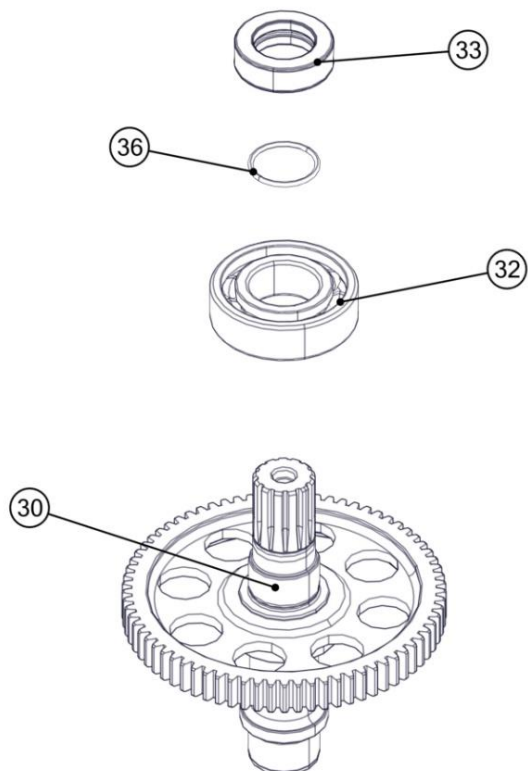

To remove the compensating ring (37) from the clutch (13) insert a pair of long nose pliers into the clutch groove.

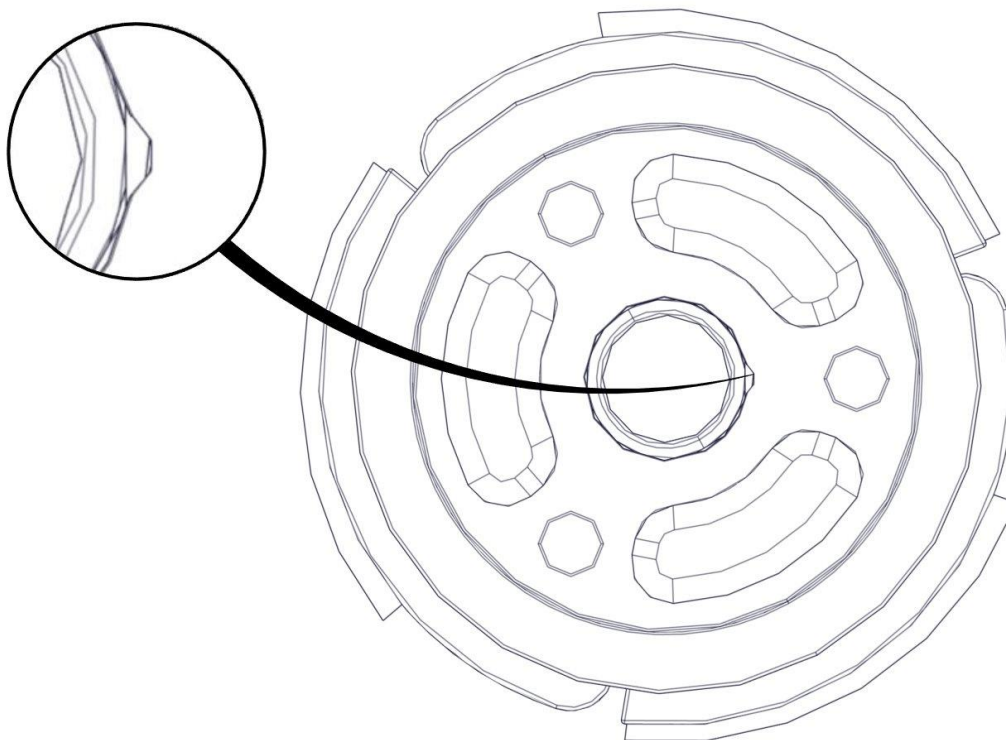

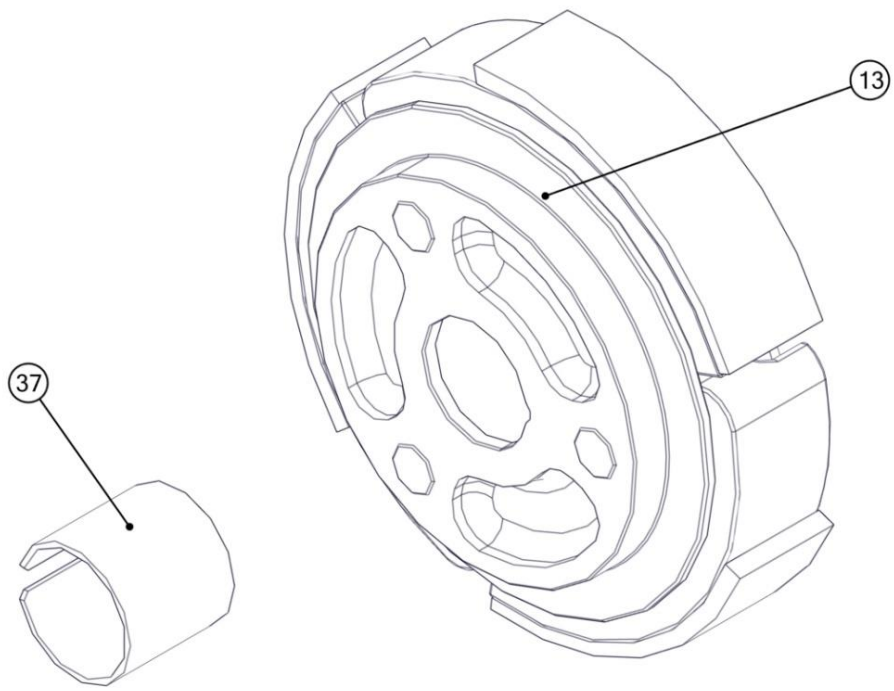

3.13.4 Transmission maintenance

Clean components thoroughly with aluminium-specific degreasers.

Check teeth:

- on the 2 gears,
- on the clutch bell
- on the propeller shaft.

Replace them if they show signs of wear or damage (as in photo).

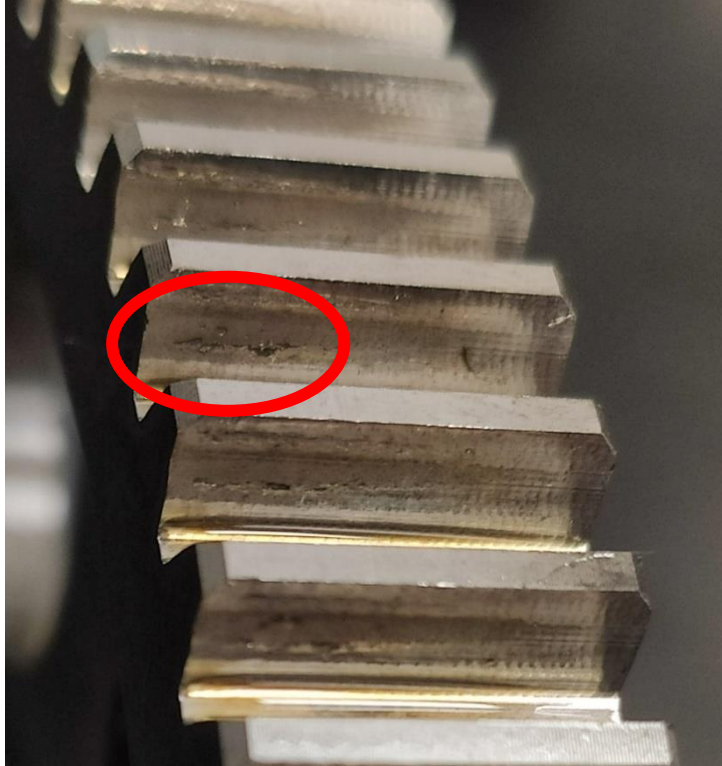

Check the clutch bell, in particular the inner surface in contact with the friction material must not show any scratches or different colouring due to overheating, otherwise (as in photo) it must be replaced. For routine maintenance, follow the table.



Measure the internal diameter of the clutch bell, the table shows the factory settings.

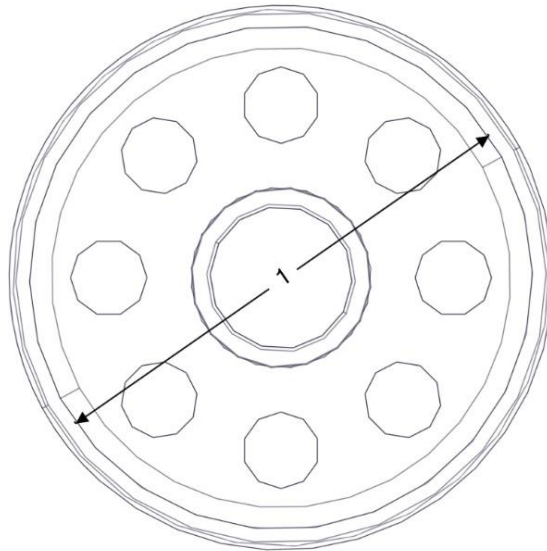

Dimension	Factory settings at 20° C (mm)
1	91,93-92,00

Check the clutch: the friction material on the pads must be intact.
If the previous check is not passed, replace the clutch. For routine maintenance, follow the table.

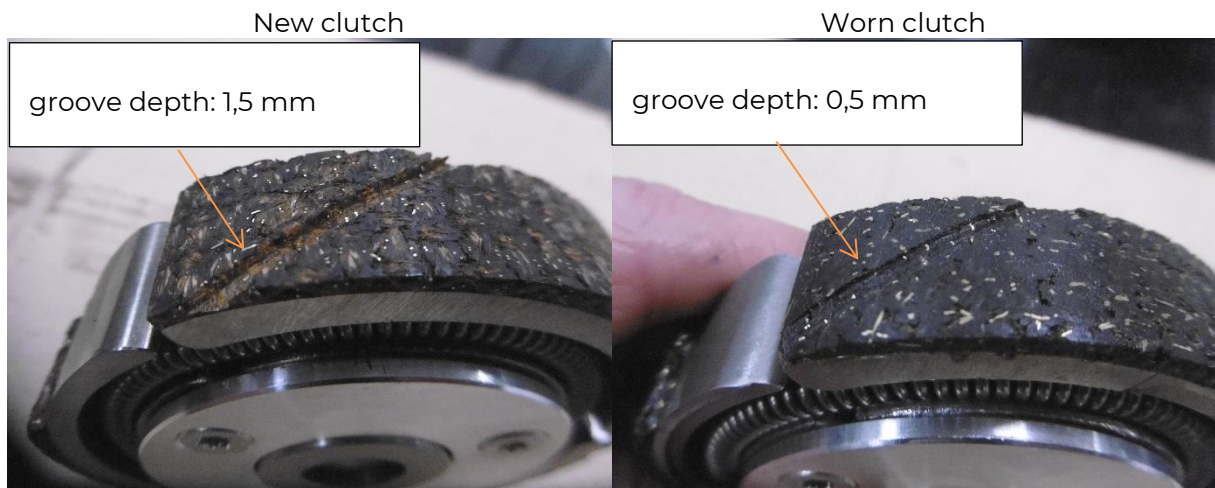

Check the propeller hub centre hole (highlighted in the figure): replace the hub if it shows signs of wear or damage.

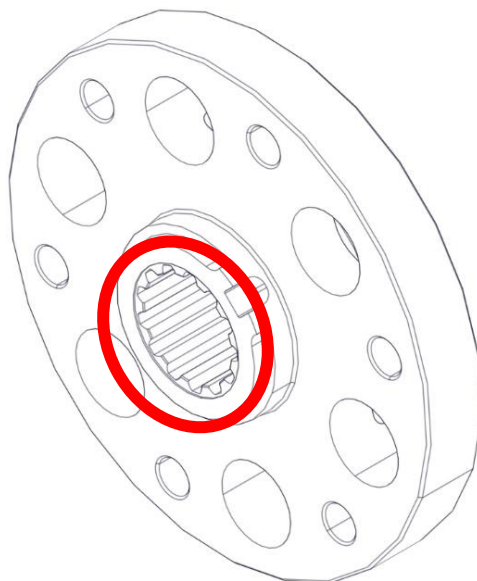

Check the key: replace the key if it shows signs of wear or damage.

Check the bushing of the transmission cover: the side surface must be smooth and free of signs of wear, otherwise it must be replaced.

Check the 3 bearing seats: there must be no polished areas. Also measure the diameter of the 3 seats, the table shows the factory settings.

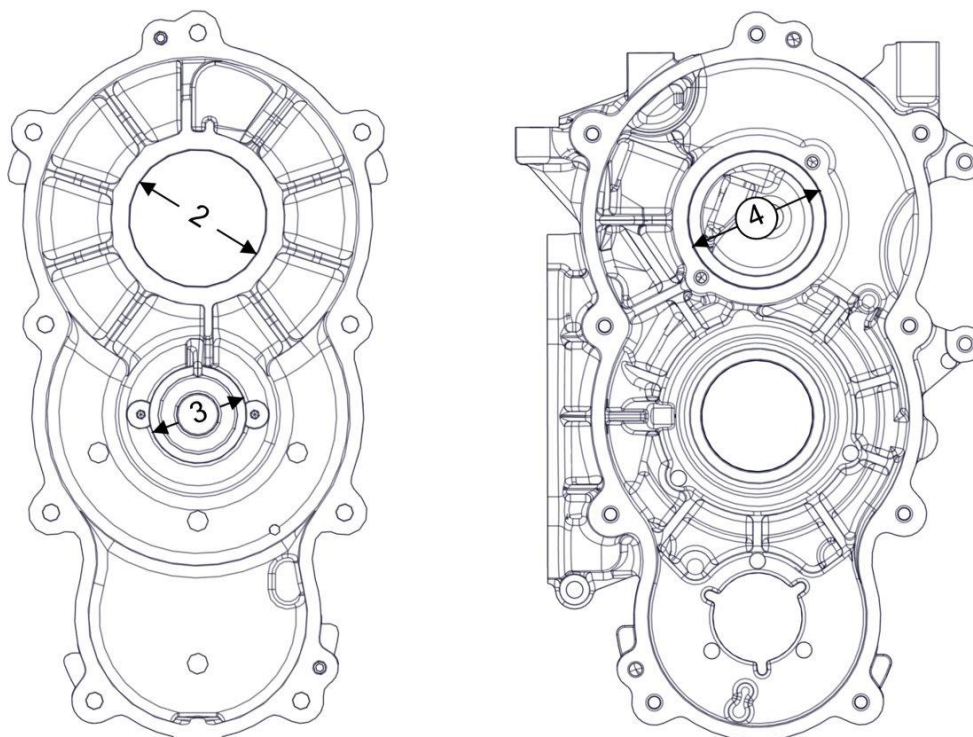

Dimension	Factory settings at 20° C (mm)
2	51,965-51,985
3	36,980-36,996
4	51,976-51,995

Measure the diameter of the 2 bearing seats, the table shows the factory settings.

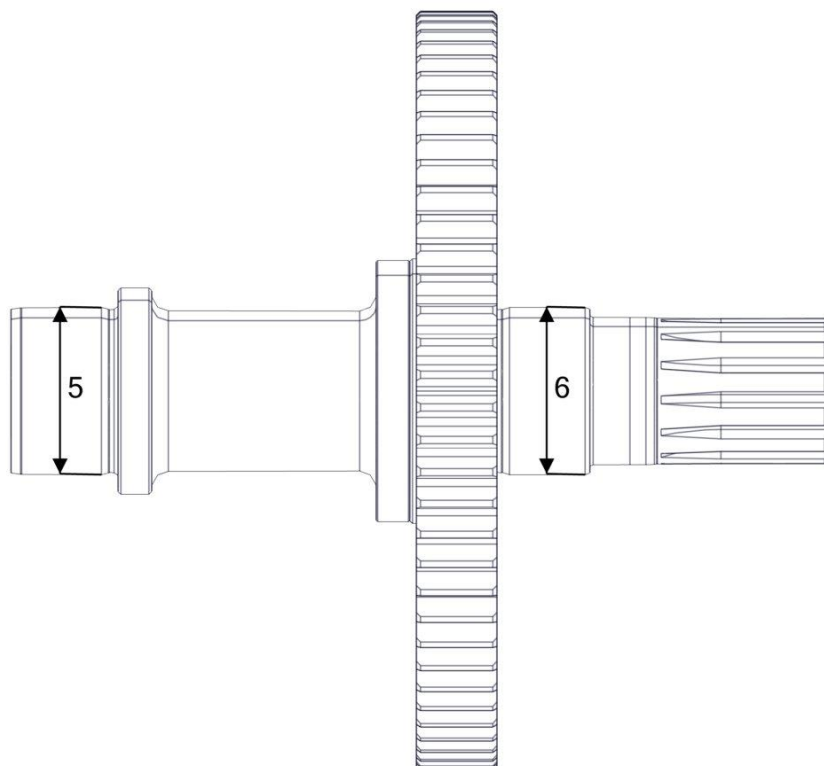

Dimension	Factory settings at 20° C (mm)
5	24,980-24,993
6	25,002-25,015

3.13.5 Transmission assembly



Check the position of the Seeger ring: the lubrication hole (38) must be between the 2 ends of the ring (39).

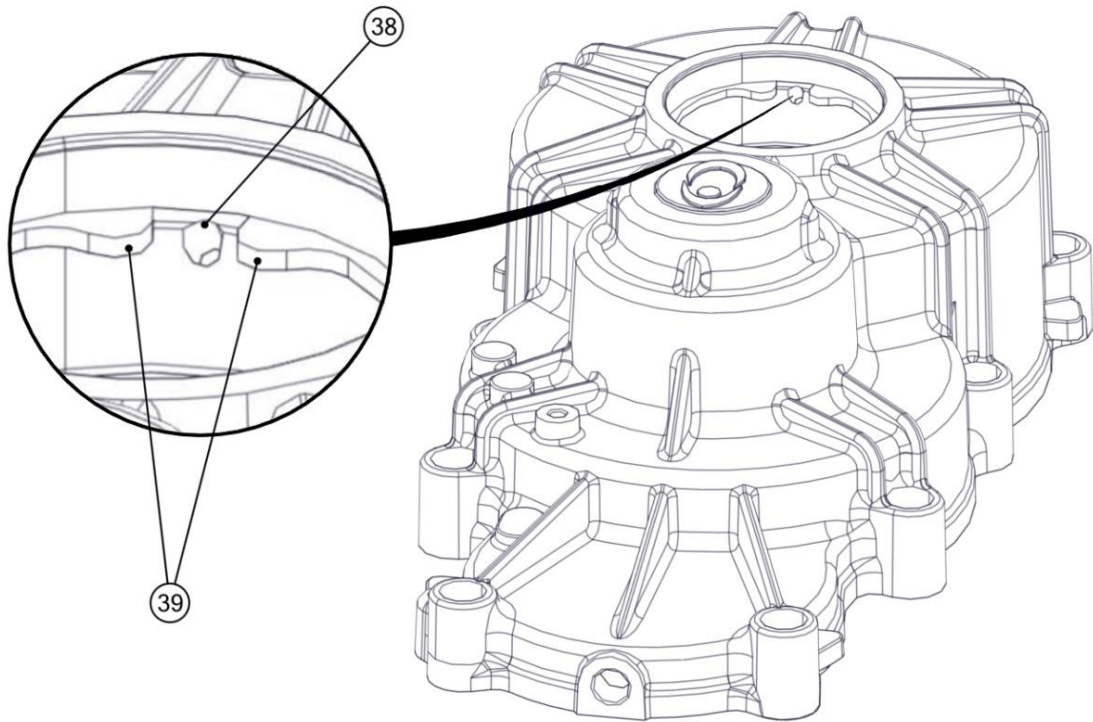

Heat the inner bearing ring (32) to 120 °C and fit it to the shaft (30) on the propeller side.

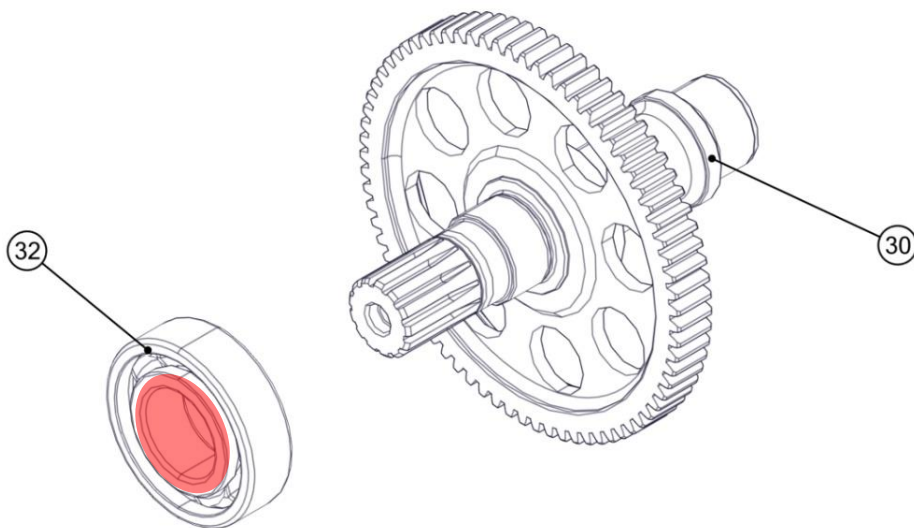

Heat the cover to 120 °C.

Insert the pinion bearing (34) and the 2 flange head screws M4x8 (31) and tighten with the torque shown in the figure.

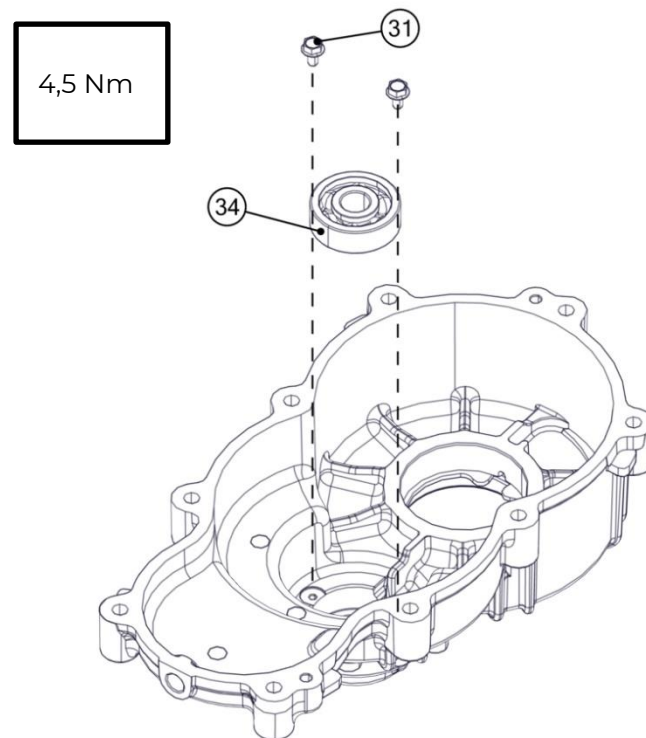

Insert the propeller shaft (30) with the bearing (32) into the cover.

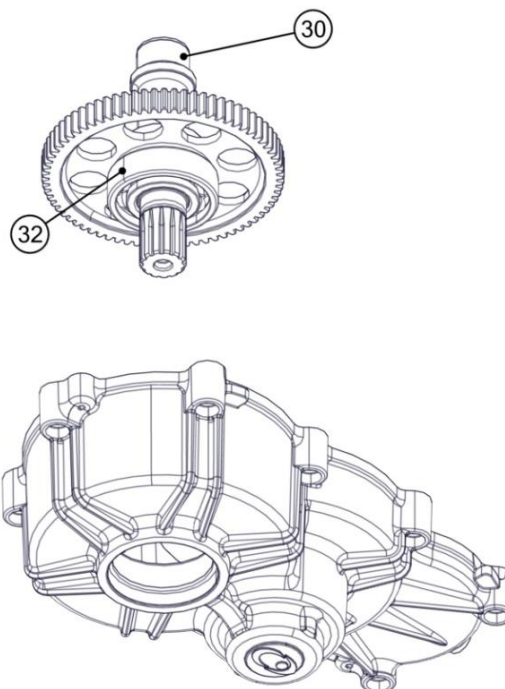

Wait a few minutes for the transmission cover to cool before continuing assembly.



Replace the propeller side oil seal (35) each time it is disassembled.

Grease the propeller side oil seal (35) with FP Silicompond 225 and place it on the transmission cover (2) using the specific tool (40) [ACC114] to insert it.

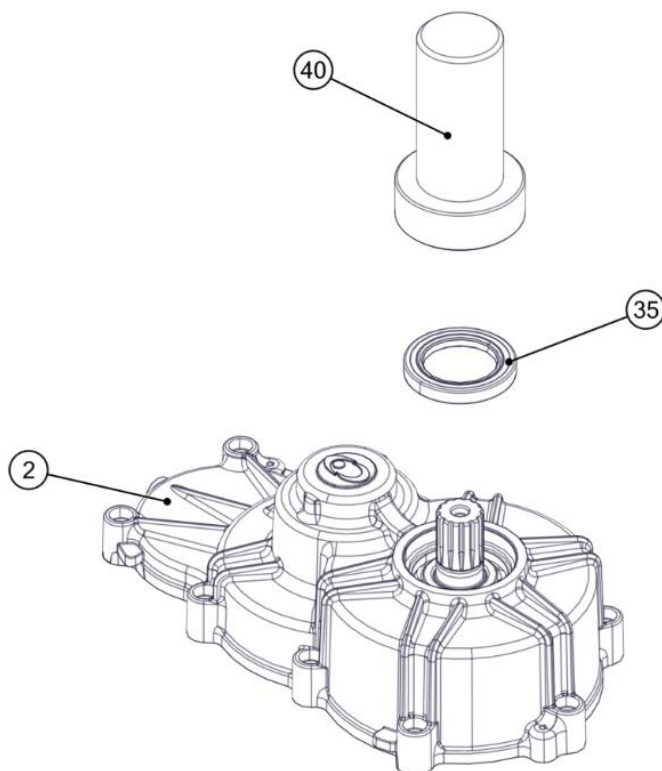



Replace the O-ring (35) each time it is disassembled.

Place the O-ring (36) in the bushing (33), grease it with FP Silicompound 225 and place it on the propeller shaft (30).

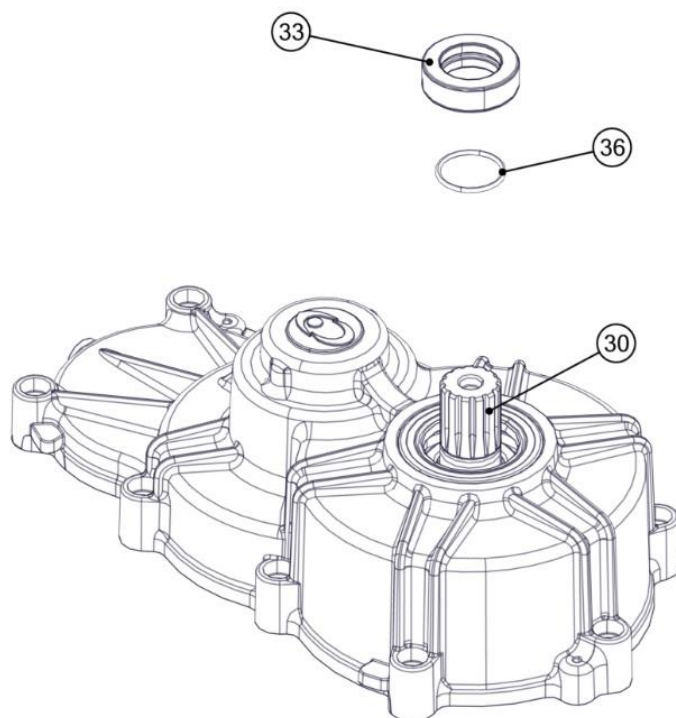

Clean and degrease the threads of the screw (27) and the propeller shaft (30) threaded hole.

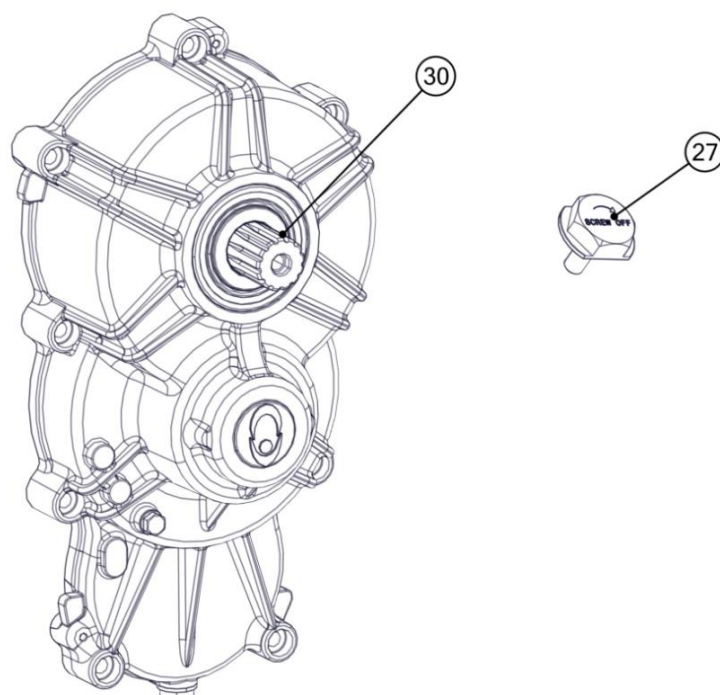



Add threadlocker (recommended Loxeal 55-03/Loctite 243): insert it into the propeller shaft (30) threaded hole. Hardening time of the threadlocker: 3 hours.



Check that the propeller hub is correct for C115p (orange anodizing). Use of the C115u propeller hub is not authorized for this model and involves a different assembly procedure.



Replace the anti-unscrewing washer (28) each time it is disassembled.

Insert the propeller hub (29), the anti-unscrewing washer (28) and the left-handed screw M8 (27).

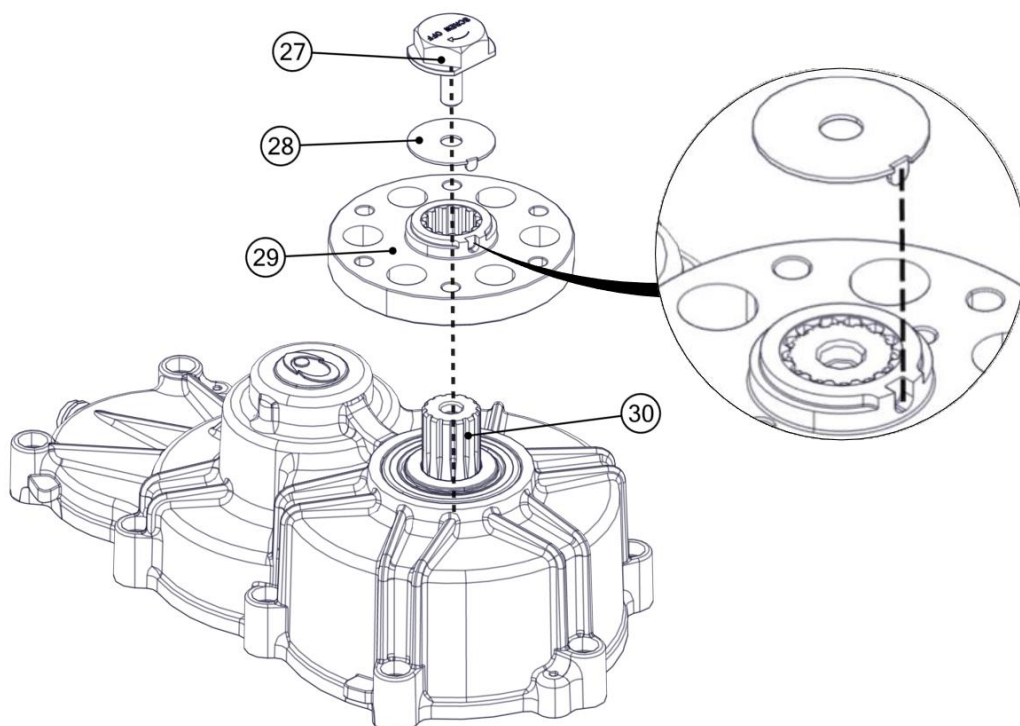

Use the propeller hub locking tool (25) [ACC110] and tighten with the torque shown in the figure.

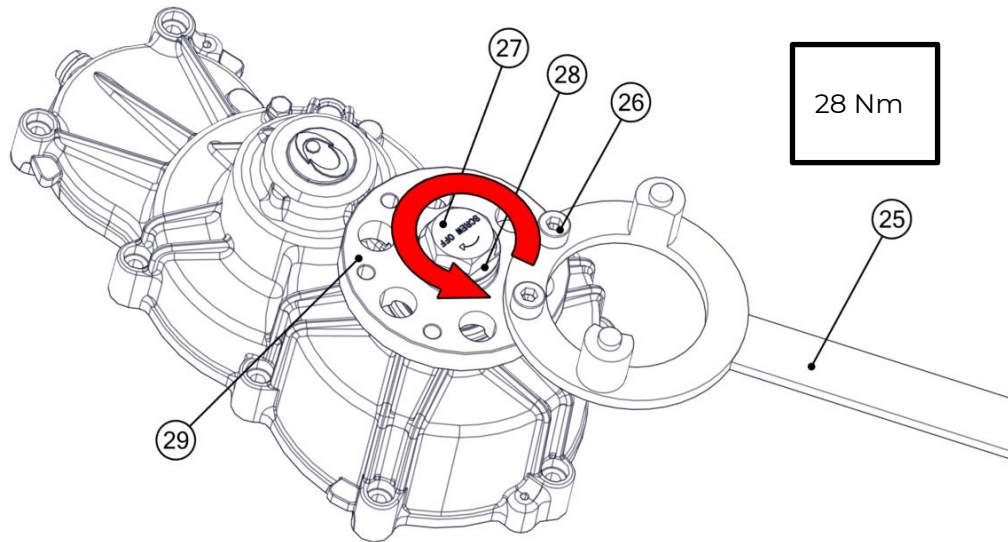

Remove the hub locking tool (25)

Bend the anti-unscrewing washer (28) as shown in the figure to make it adhere perfectly to one face of the hexagon of the screw.

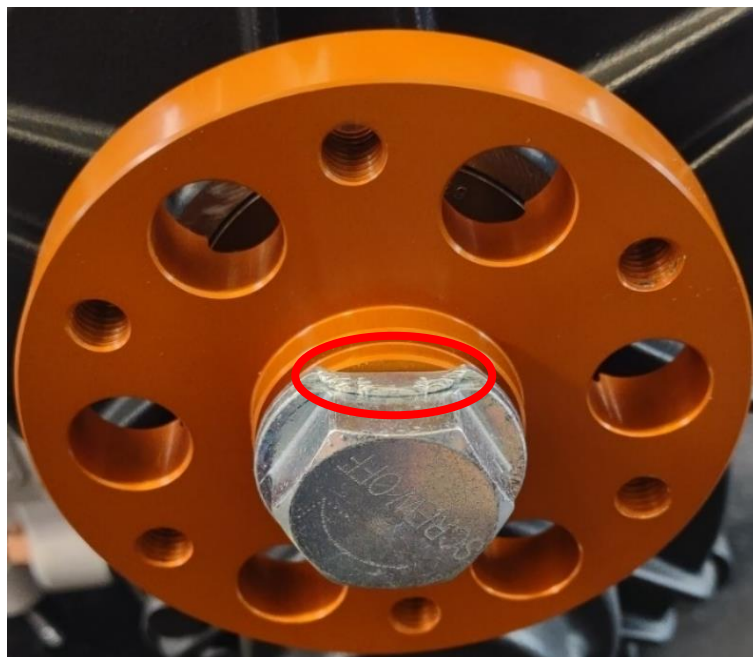

Heat the upper bearing seat to 120 °C and insert the propeller shaft bearing (24).

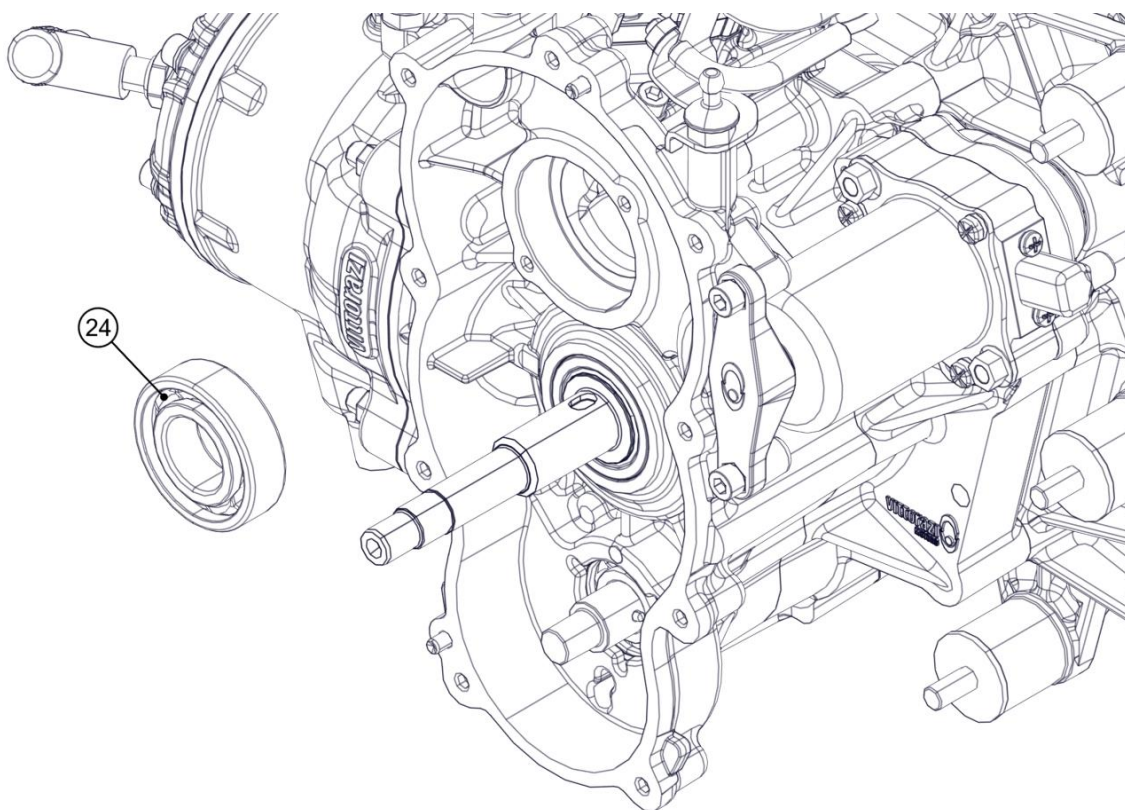

Insert the key (23) on the crankshaft (10).

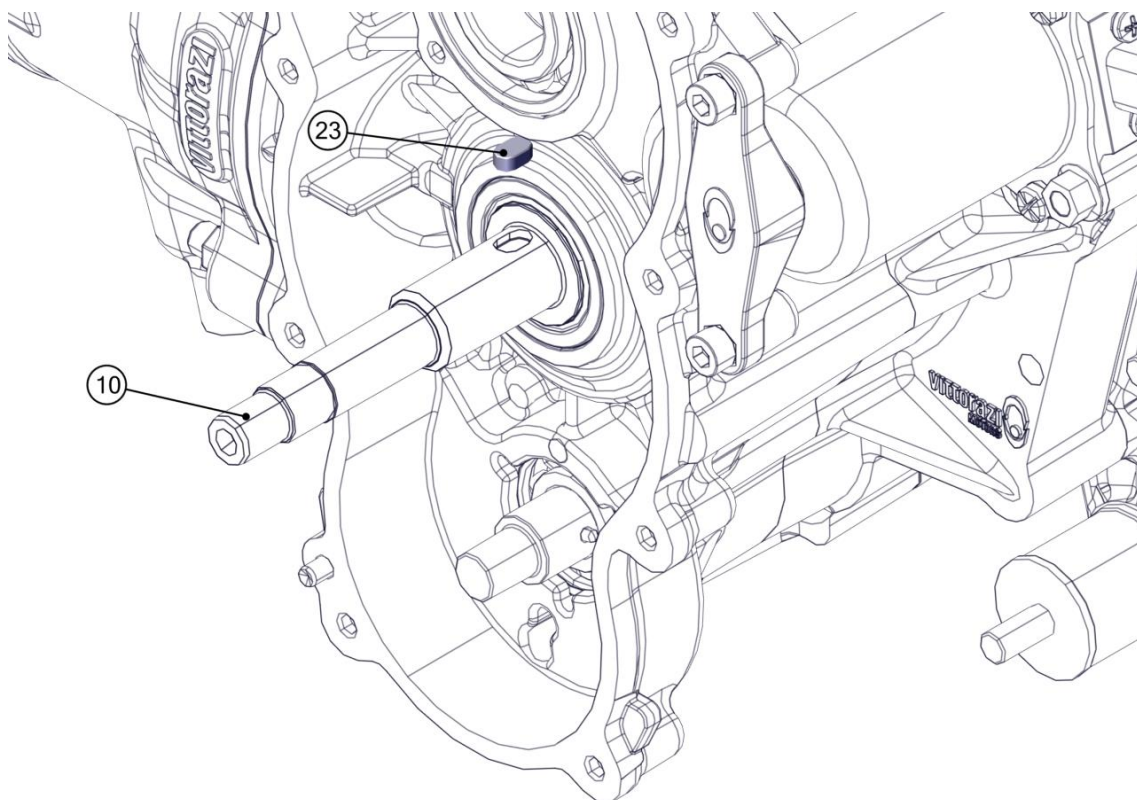

Insert the driving gear (22) on the crankshaft (10).

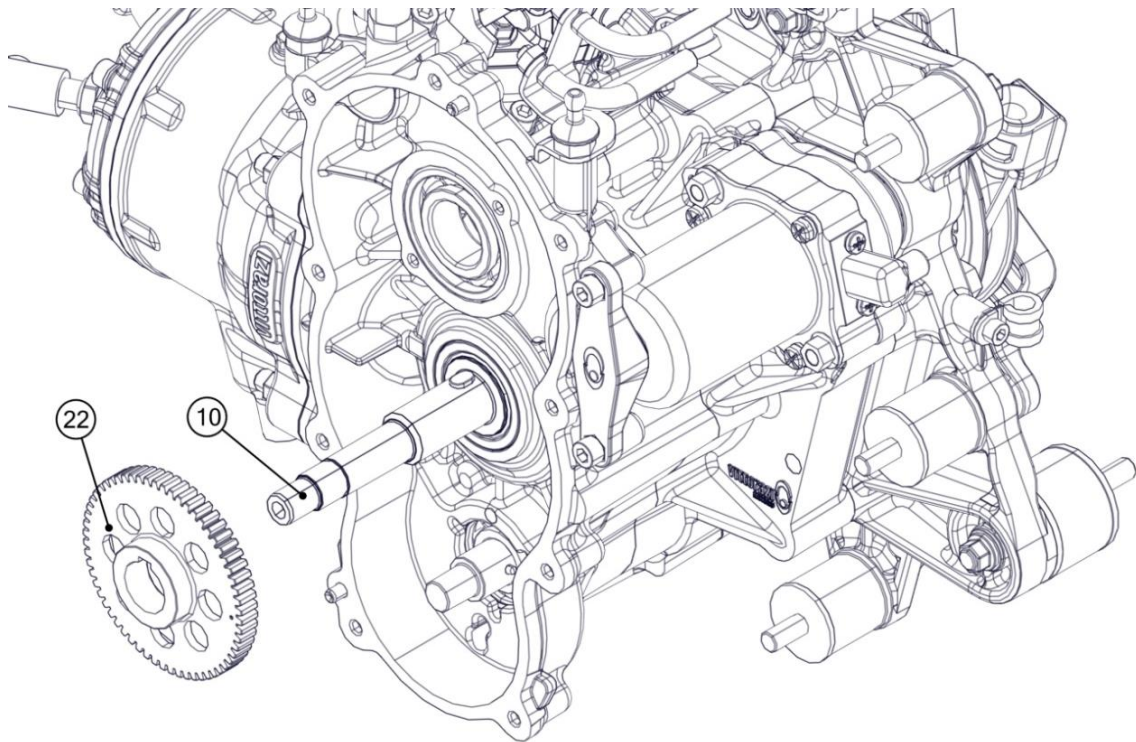

Turn the crankshaft to have the reference point (indicated by a dot near the tothing) at the bottom.

Turn the countershaft to obtain the alignment shown in the figure.

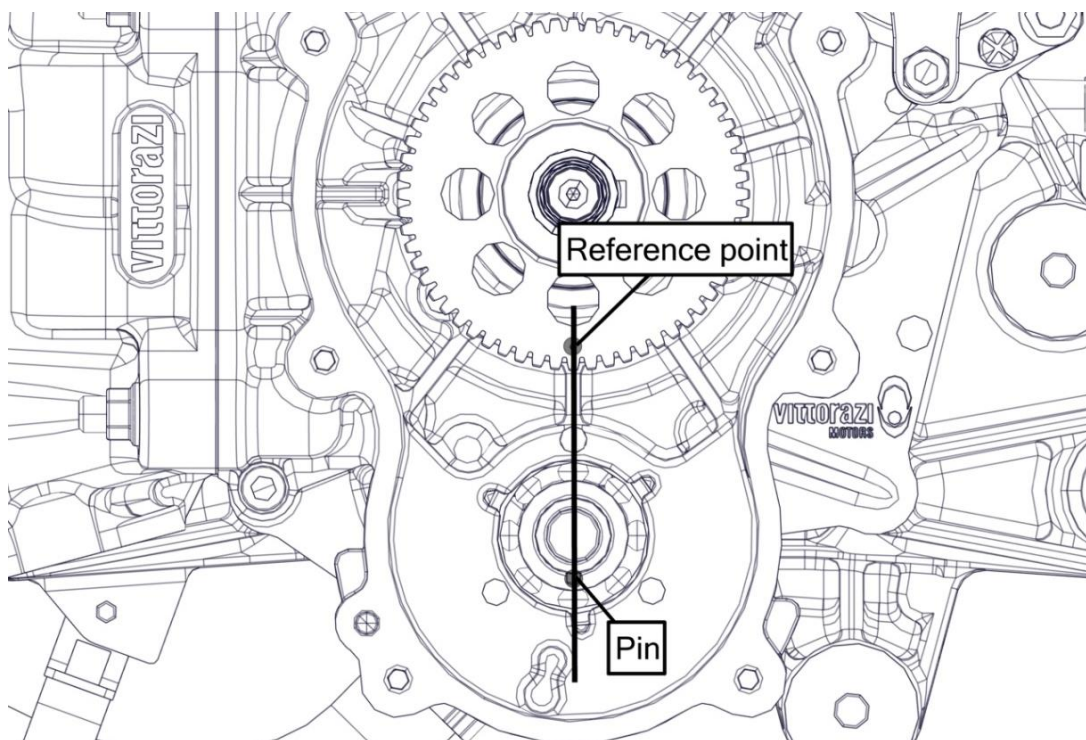

Check that the pin is on the countershaft before continuing with the assembly.

Insert the driven gear (21) on the countershaft (20) aligning the 2 points on the gears.

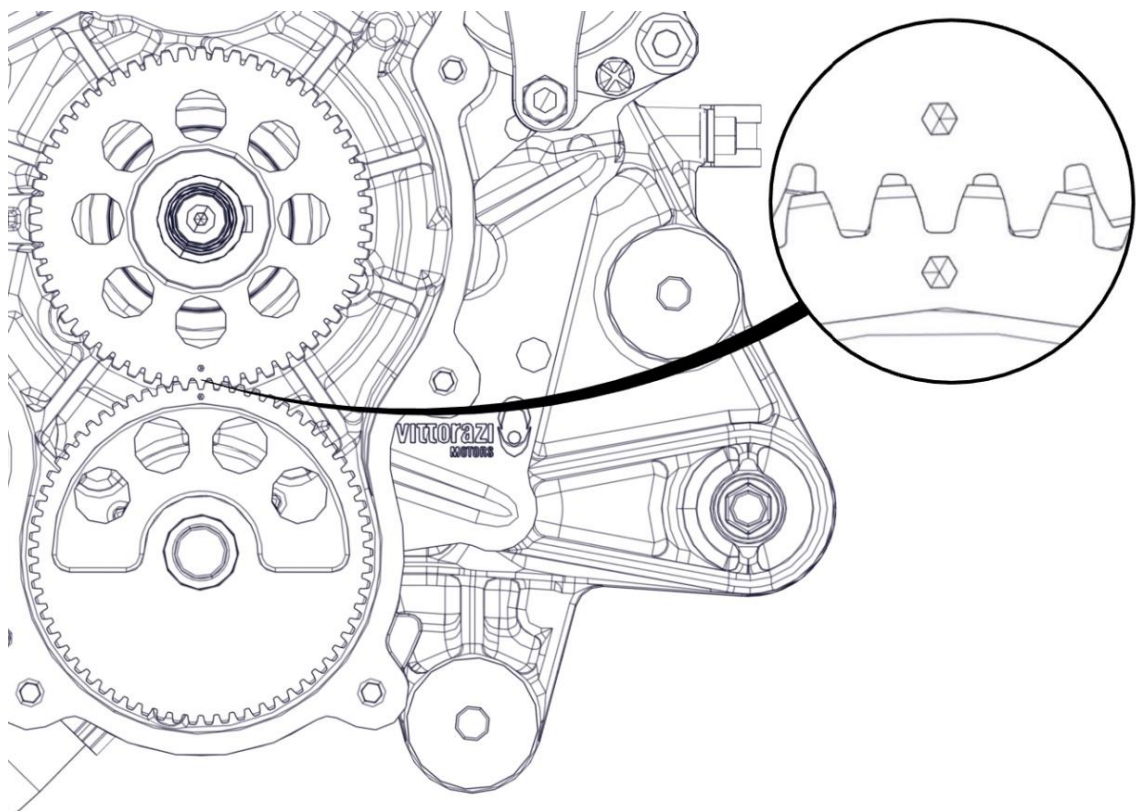
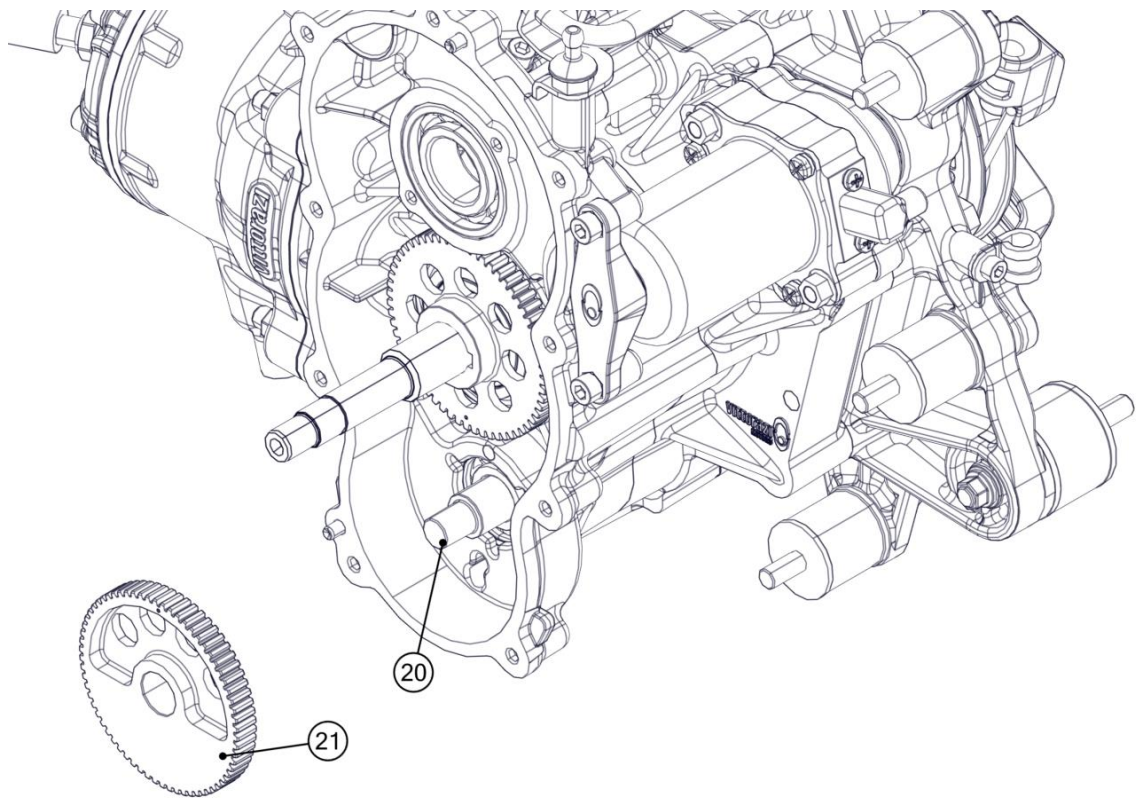

Insert the part A of the transmission locking tool [ACC112] into the holes of the 2 gearwheels.
The positioning of the transmission locking tool as shown in the figure confirms that the 2 gears have been mounted with the correct phase.

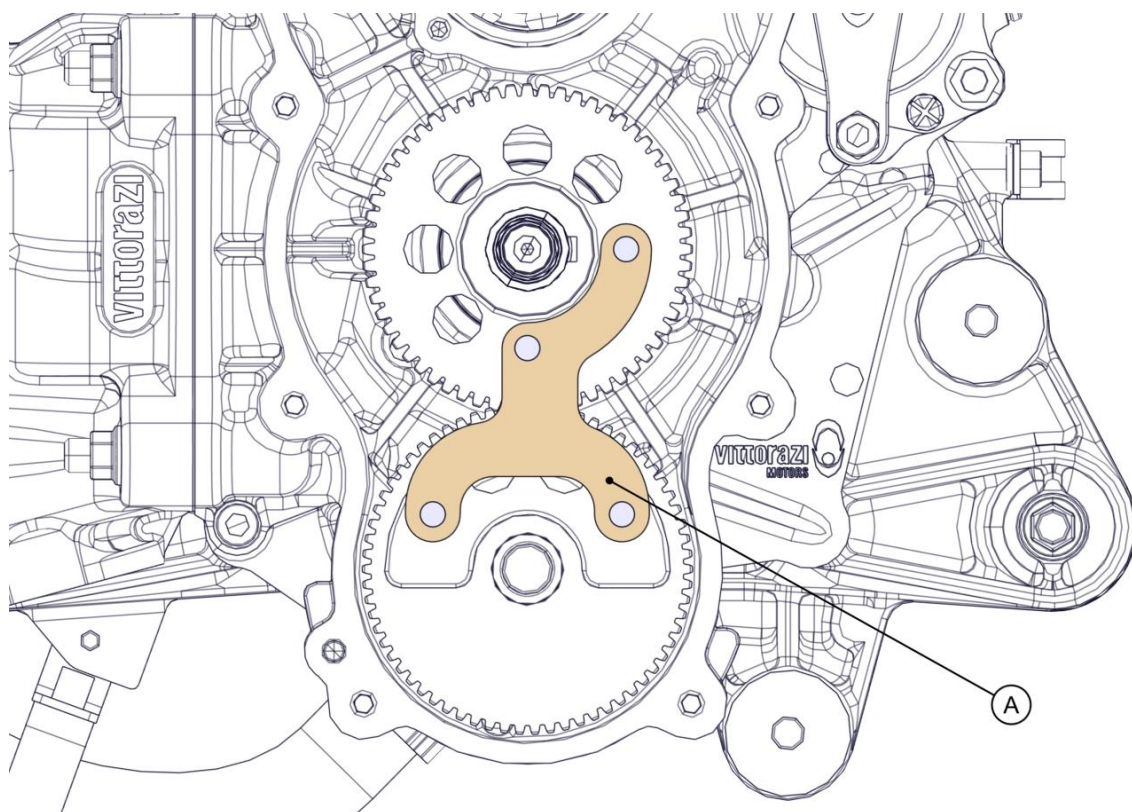

Insert the part B of the transmission locking tool as shown in the figure.
Secure the locking tool with the 2 Allen screws M6x20 (5).

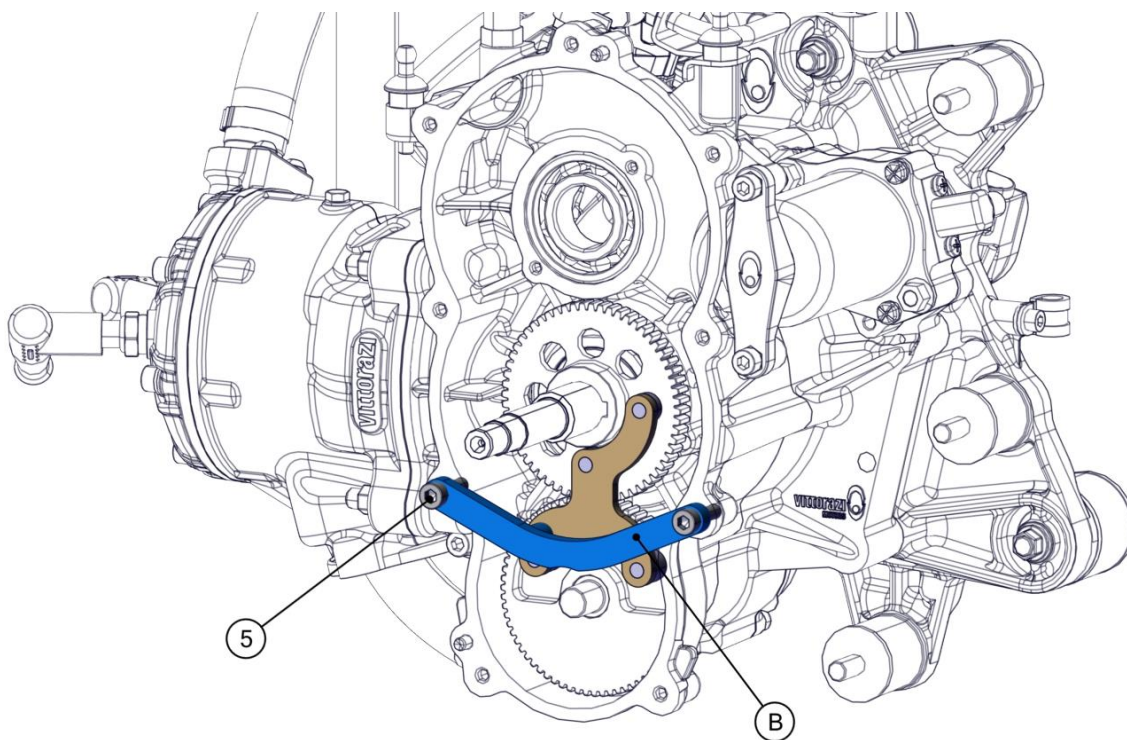



Replace the washer (19) each time it is disassembled.

Insert the nut M12x1,25 (18) with the washer (19) on the countershaft (20) and tighten with the torque shown in the figure.

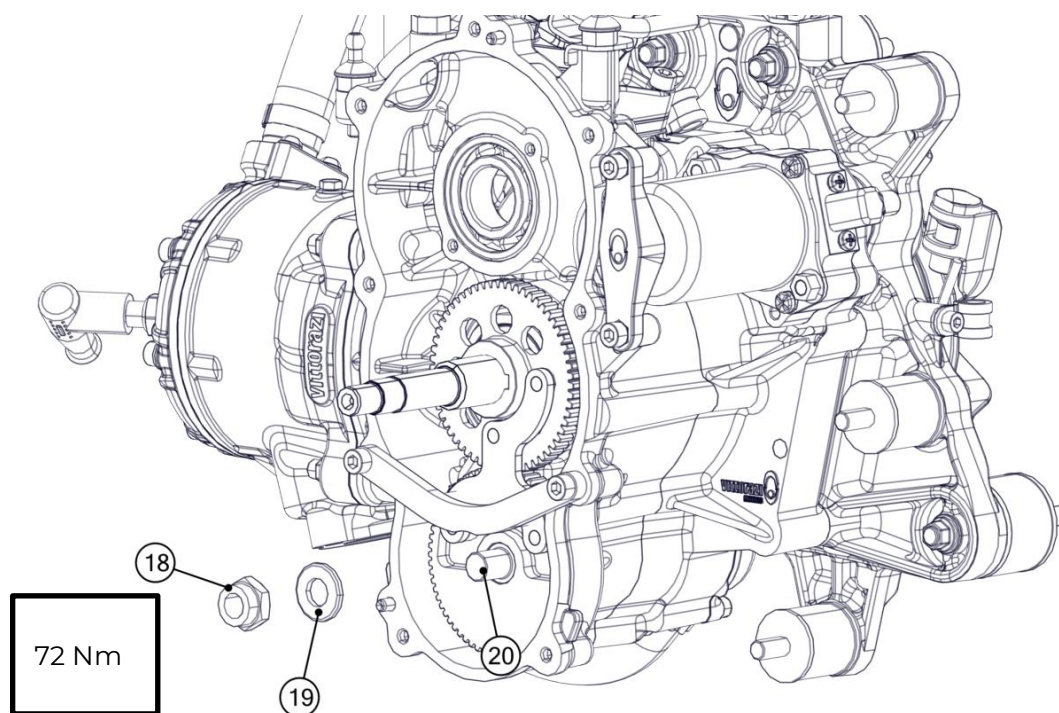

Insert the clutch plate (14), the 3 Torx screws M5x14 (12) on the clutch (13) and tighten with the torque shown in the figure.

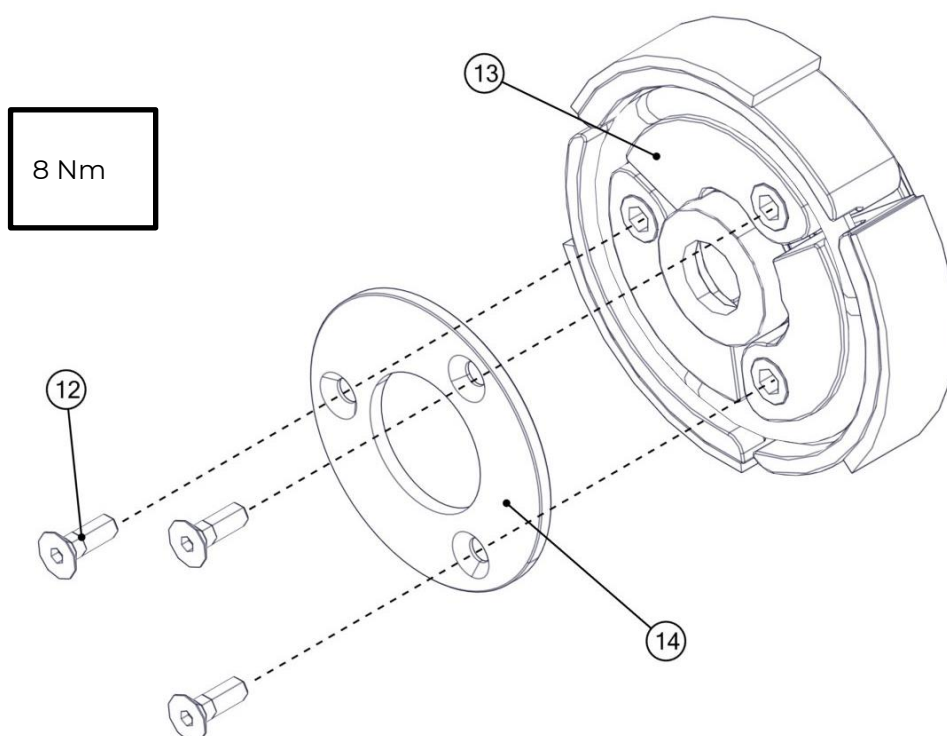



Before fitting the new clutch, carry out the operations described on this page.

Provisionally position the old clutch, without the compensating ring, on the crankshaft until it is in contact with the gearwheel.

Measure the distance between the clutch plane (A) and the transmission cover separation plane (B) as shown in the figure.

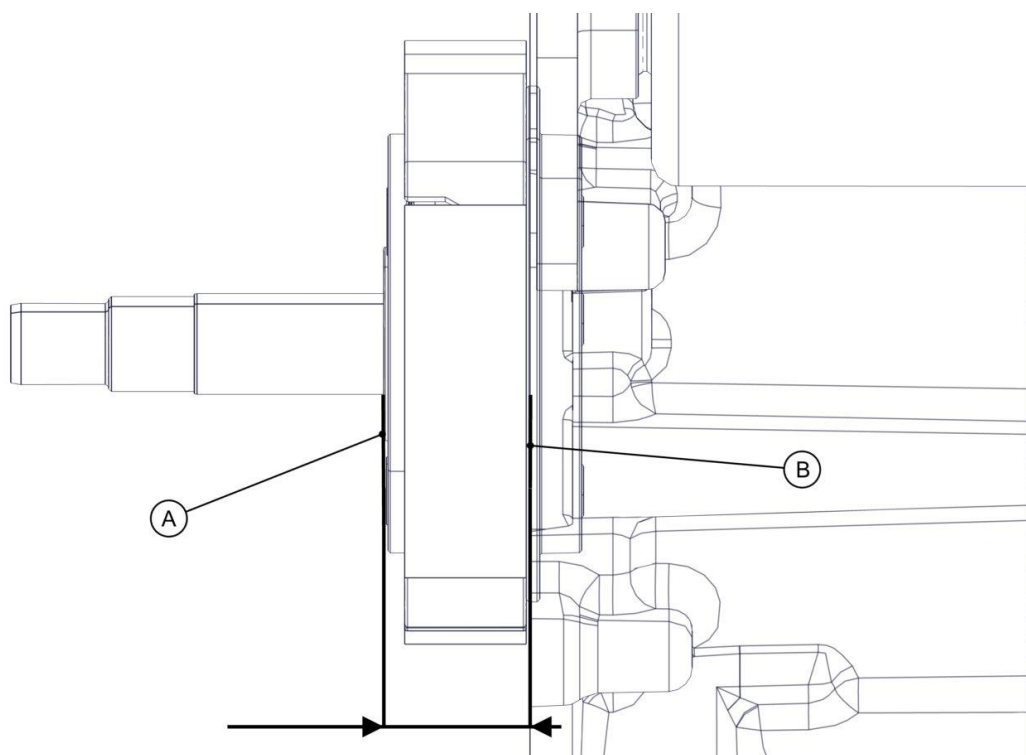
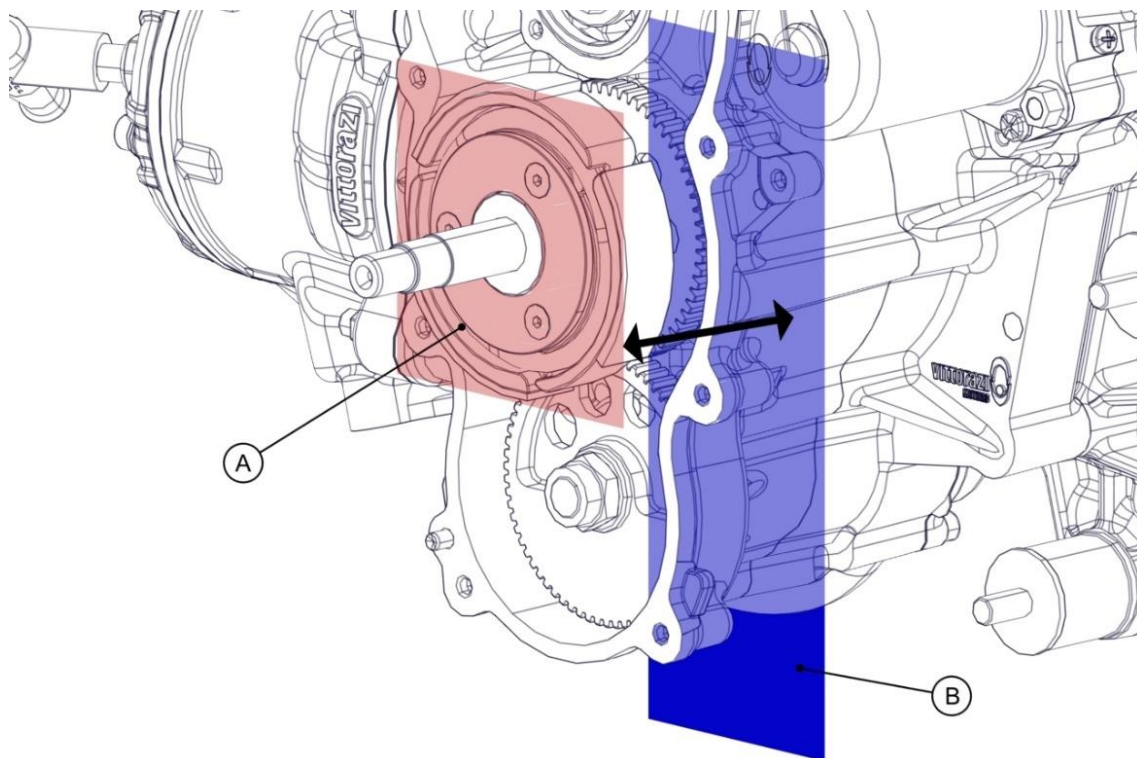

Remove the old clutch.



Replace the compensating ring (37) each time it is disassembled.

Insert the compensating ring (37) into the clutch (13) by positioning the ring opening 180° from the clutch groove (highlighted in the figure).

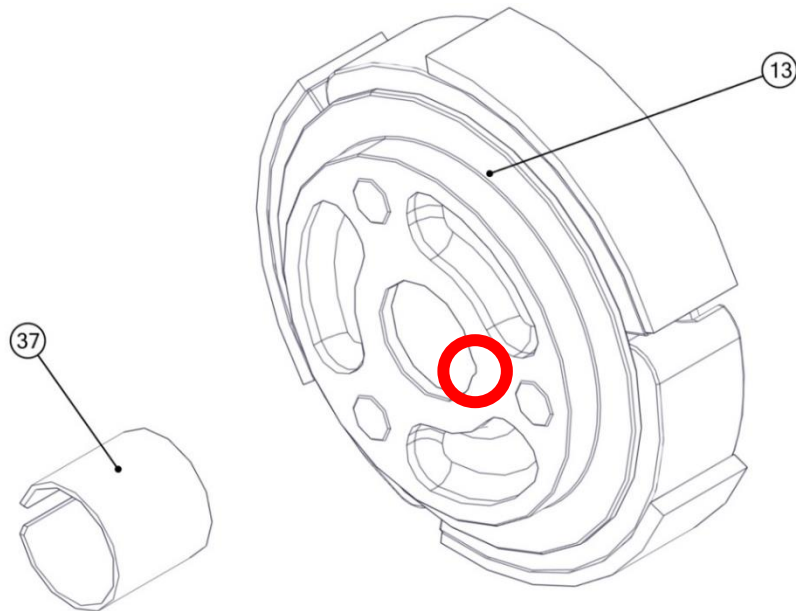

Lubricate the surface of the crankshaft.
Insert the clutch (13) on the crankshaft (10) without looking for a phase.

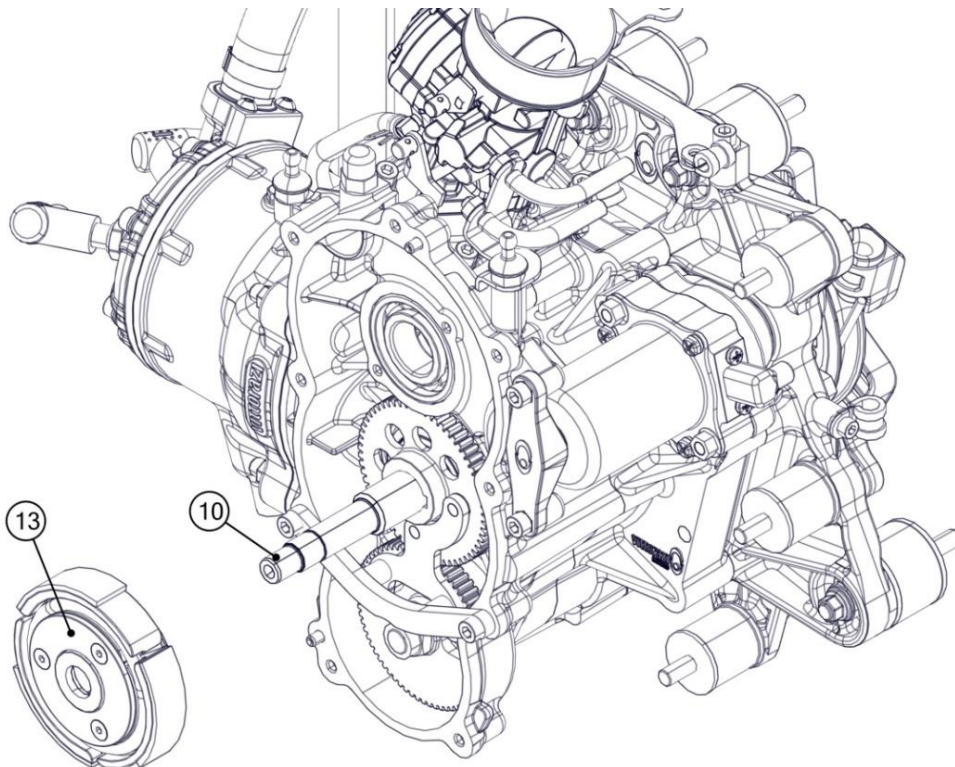

Prepare the clutch assembly tool [ACC115] as shown in the figure: screw part A completely onto part B.

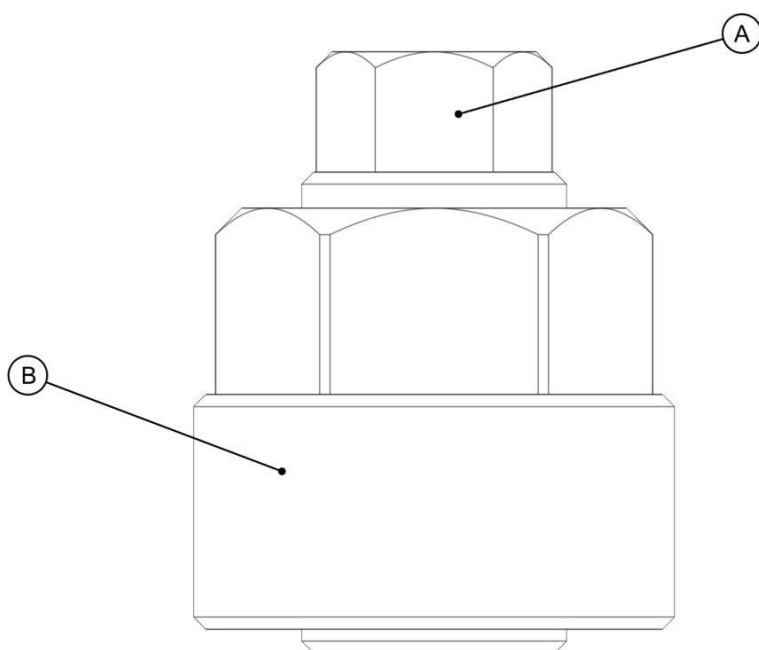

Screw part A completely onto the crankshaft with a 17 mm spanner. Turn the part B with a 32 mm spanner and apply the torque shown in the figure.

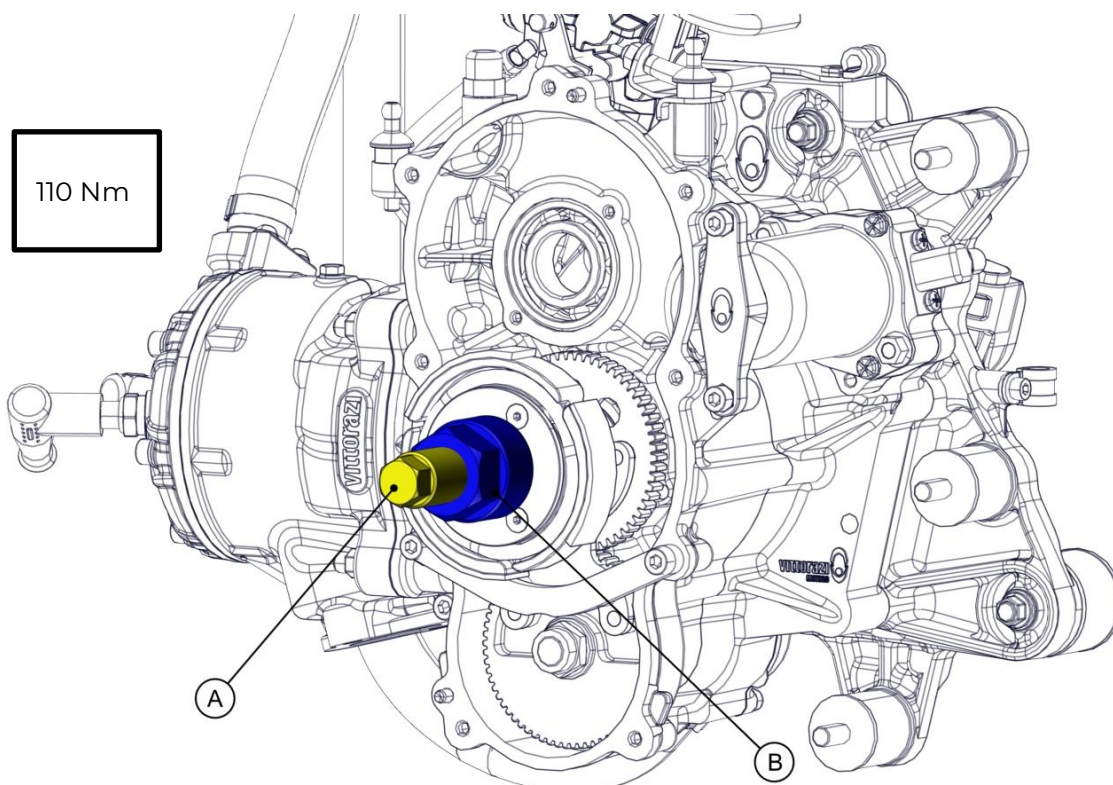

To remove the clutch assembly tool, unscrew both parts of the tool (A, B) at the same time.



Measure again the distance between the clutch and the transmission cover separation plane. Check that it coincides with the measurement taken previously.

Lubricate the roller bearings, the clutch bell and the surface of the crankshaft with transmission oil.

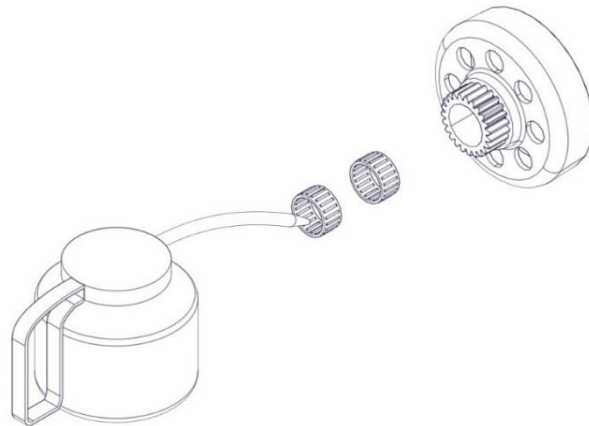

Insert the bushing (11) and the 2 roller bearings (9) on the crankshaft (10).
Insert the clutch bell (8).

Insert the nut M14x1,5 (6) with the washer (7) and tighten with the torque shown in the figure.



Use a torque wrench, do not use a pneumatic impact screwdriver.

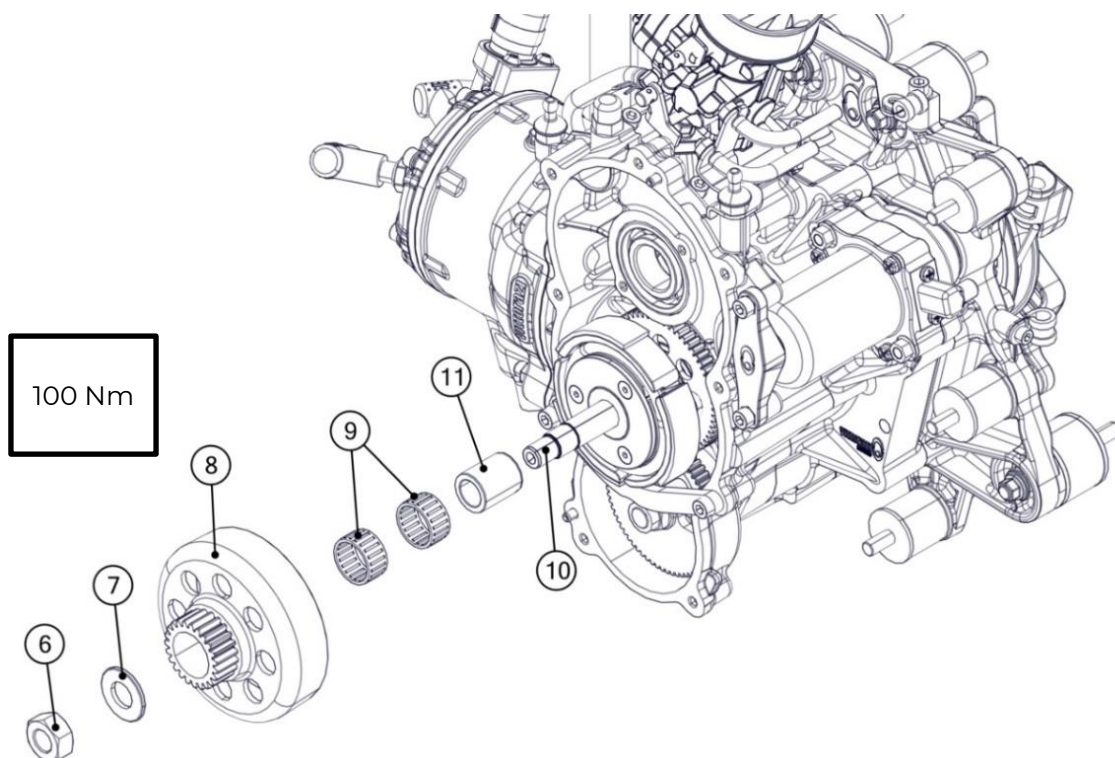

Remove the 2 Allen screws M6x20 (5).
Remove the part B.
Remove the part A.

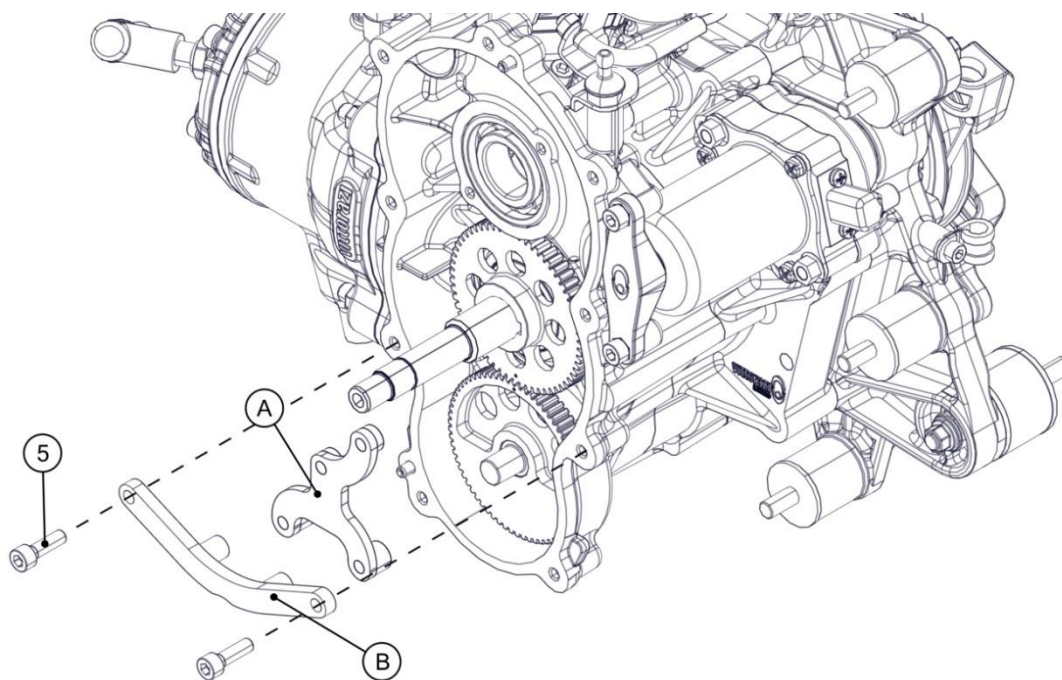

Replace the gasket (4) each time it is disassembled.

Place the gasket (4) on the 2 pins (38).
Insert the previously assembled transmission cover (2).

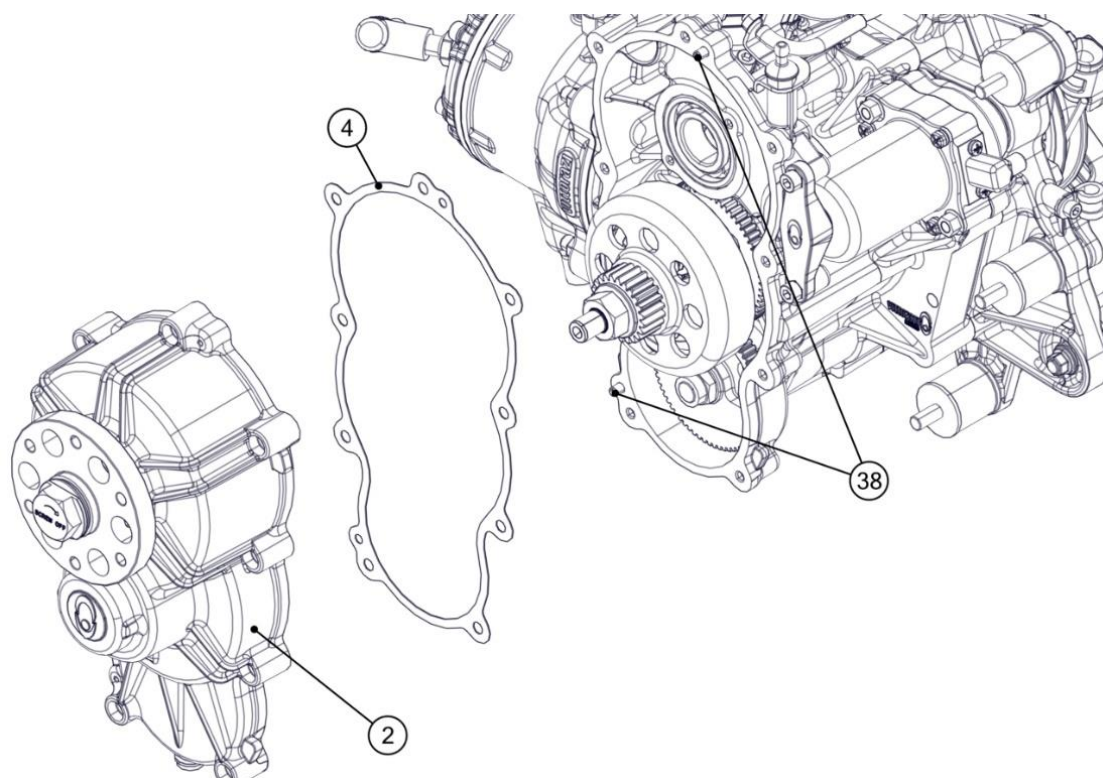

Insert and pre-tighten alternately the 2 highlighted Allen screws M6x30.

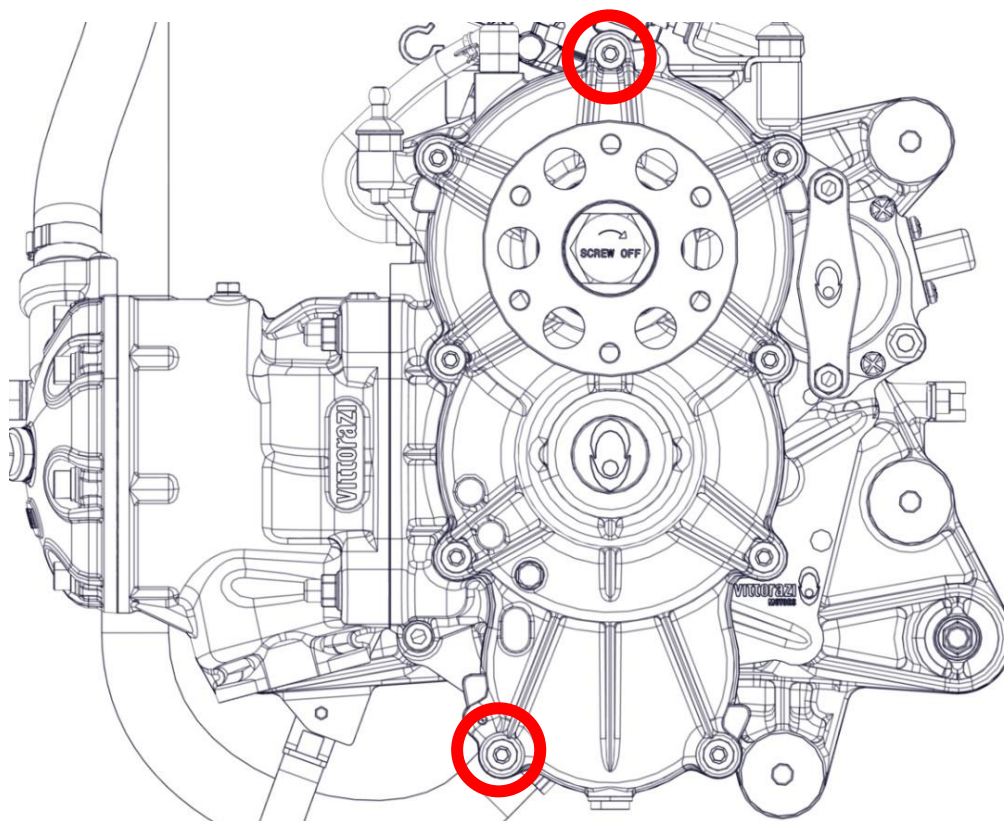

Insert the remaining 7 Allen screws M6x30 (1) into the cover (2).

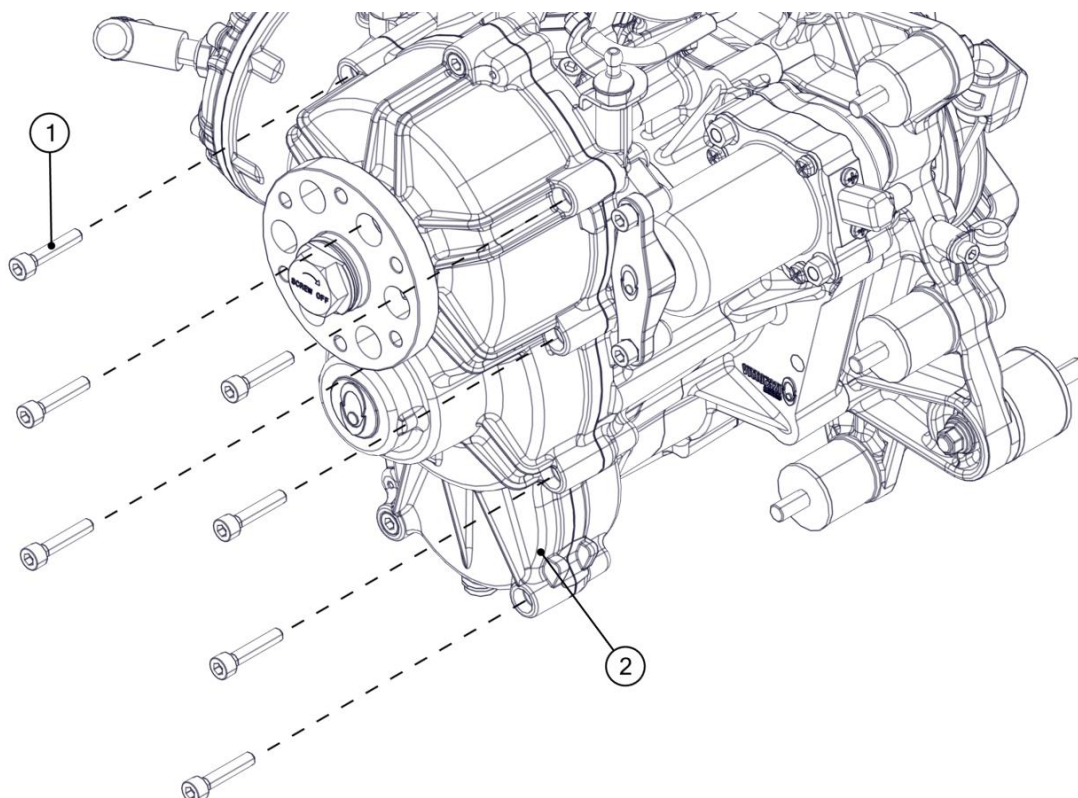

Pre-tighten progressively, then tighten in the order and with the torque shown in the figure.

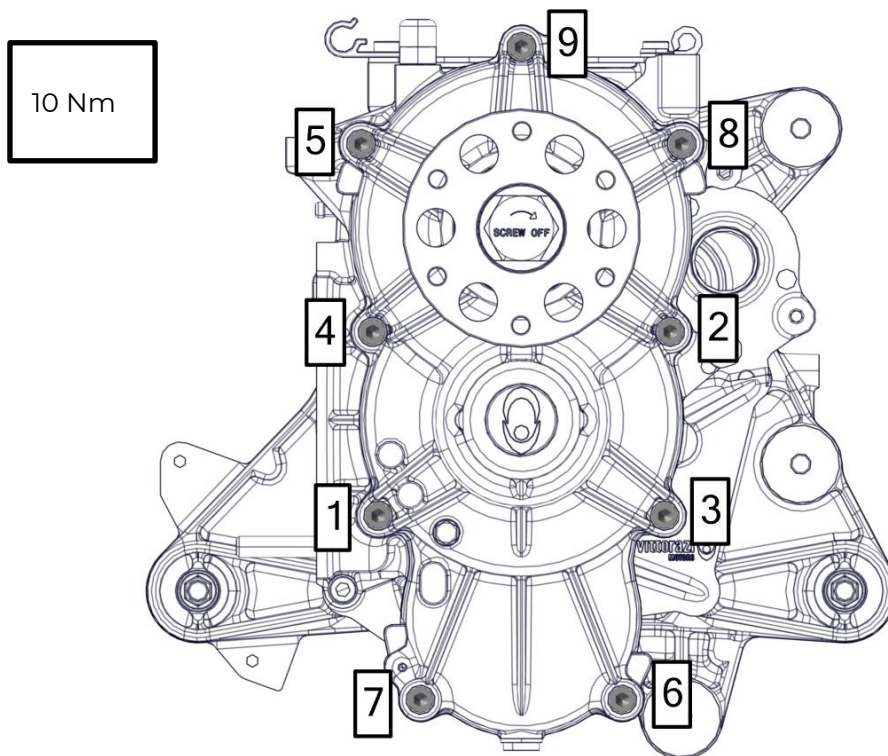

Check that all screws are tightened correctly in clockwise order.



After assembly, fill the transmission with oil.

3.13.6 Transmission assembly – ULM model



Check the position of the Seeger ring: the lubrication hole (38) must be between the 2 ends of the ring (39).

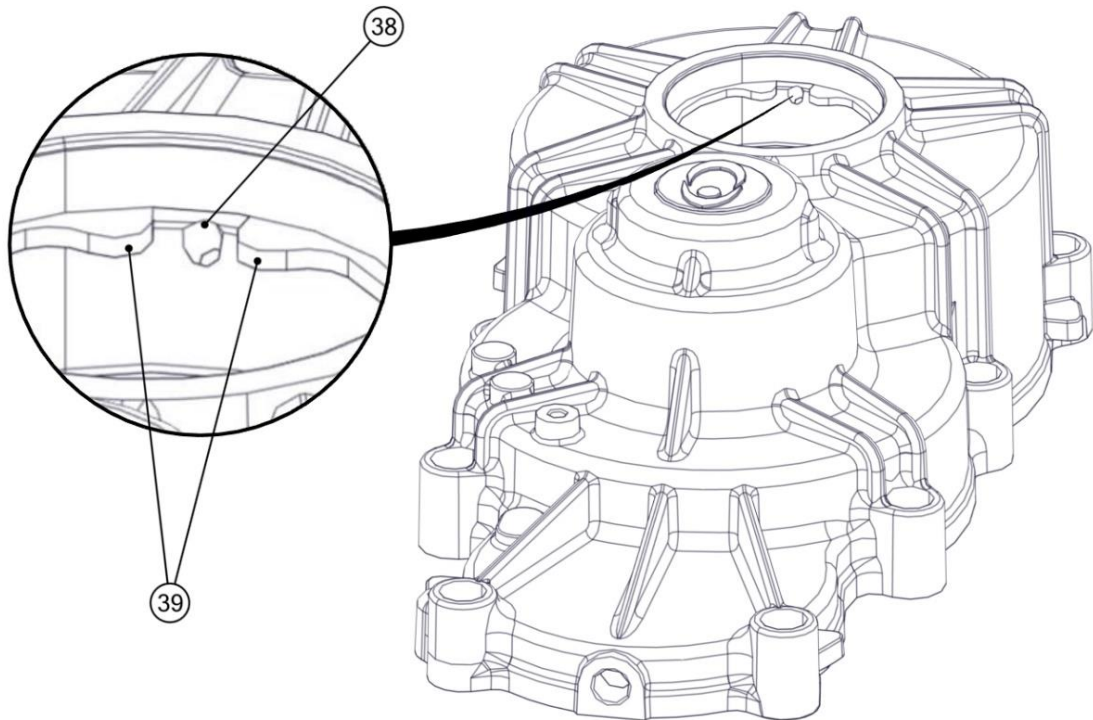

Heat the inner bearing ring (32) to 120 °C and fit it to the shaft (30) on the propeller side.

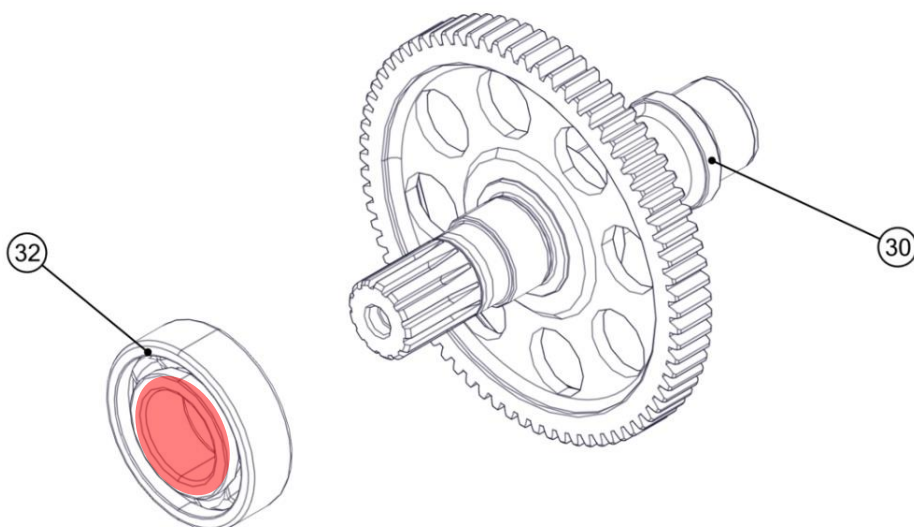

Heat the cover to 120 °C.

Insert the pinion bearing (34) and the 2 flange head screws M4x8 (31) and tighten with the torque shown in the figure.

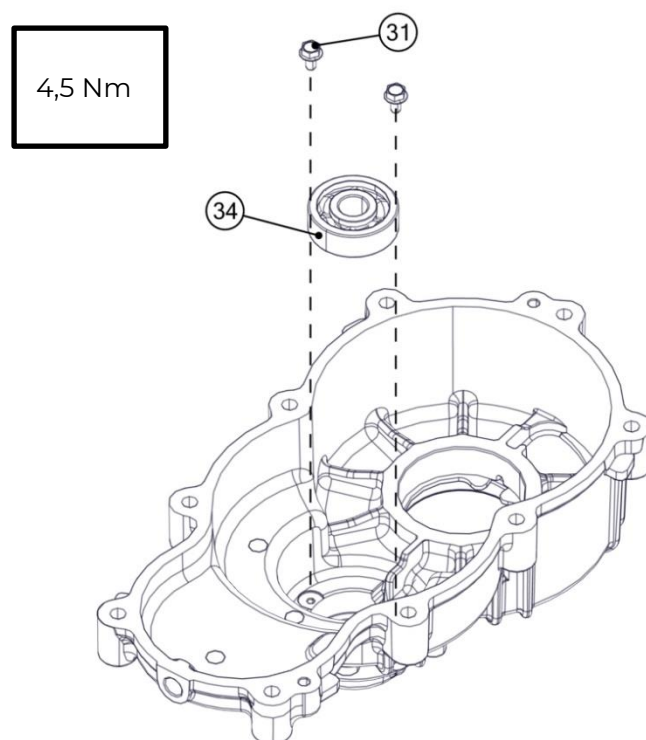

Insert the propeller shaft (30) with the bearing (32) into the cover.

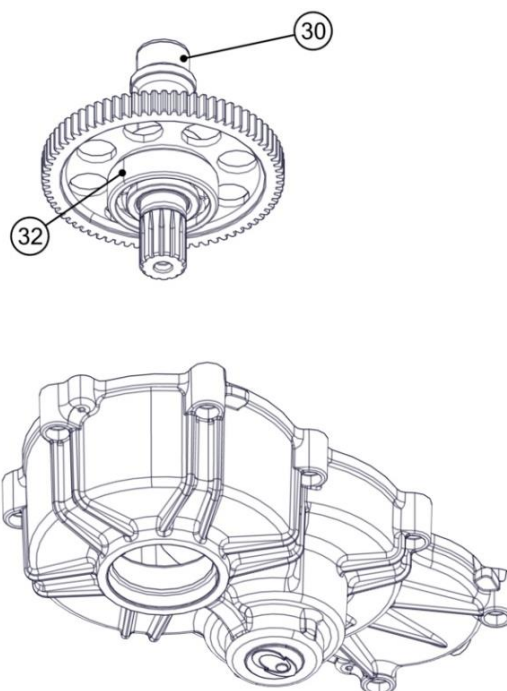

Wait a few minutes for the transmission cover to cool before continuing assembly.



Replace the propeller side oil seal (35) each time it is disassembled.

Grease the propeller side oil seal (35) with FP Silicompond 225 and place it on the transmission cover (2) using the specific tool (40) [ACC114] to insert it.

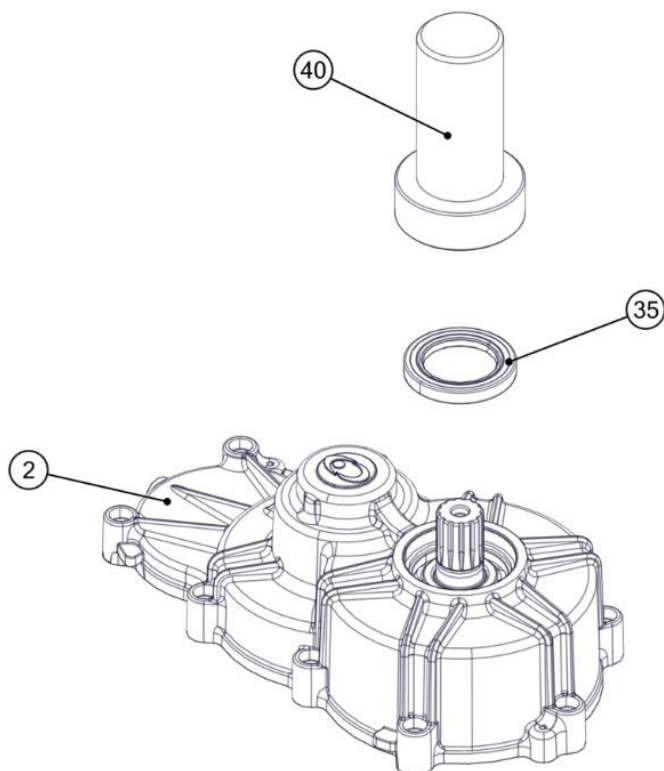



Replace the O-ring (35) each time it is disassembled.

Place the O-ring (36) in the bushing (33), grease it with FP Silicompound 225 and place it on the propeller shaft (30).

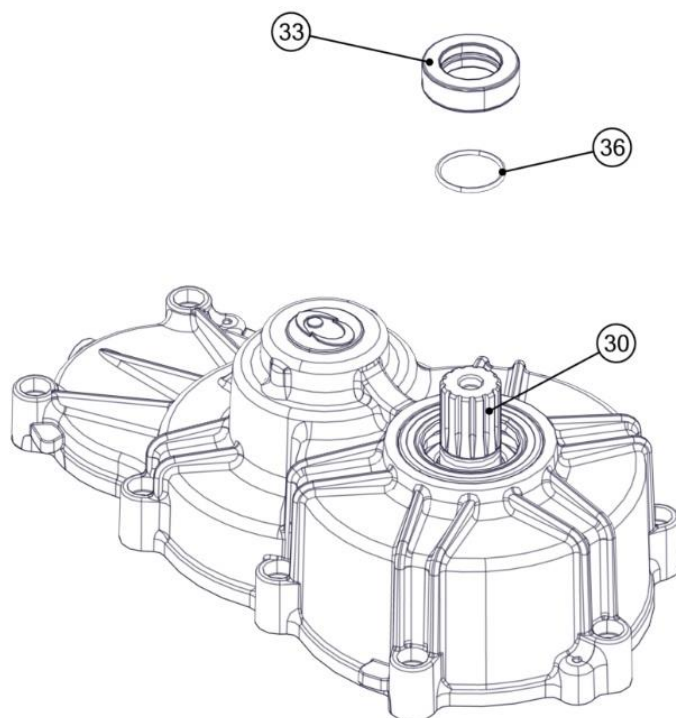

Clean and degrease the threads of the screw (27) and the propeller shaft (30) threaded hole.

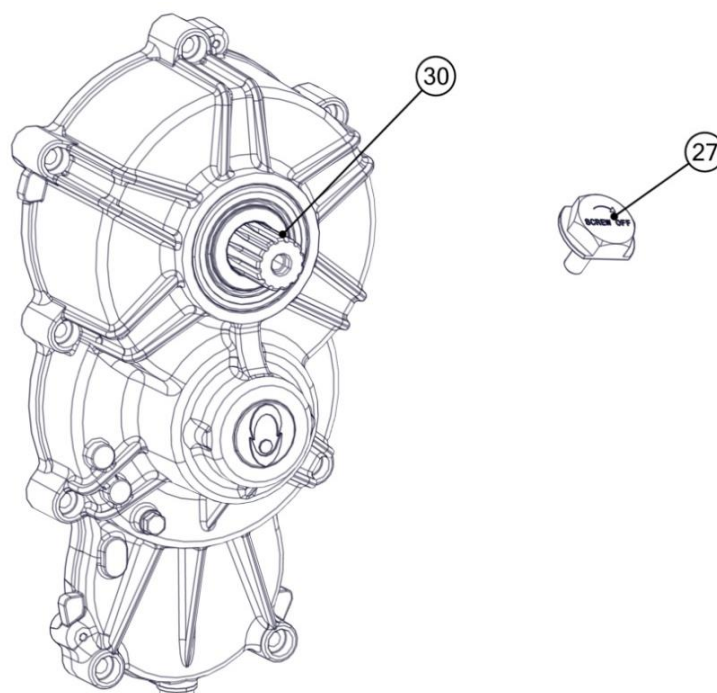



The coupling between the drive shaft and the hub is ensured by mechanical interference. Therefore, for safety reasons, replace the propeller hub each time it is disassembled.



Check that the propeller hub is correct for C115u (black-grey anodizing). Use of the C115p propeller hub is dangerous for this model and involves a different assembly procedure.

Place the shaft on a stable support and carefully align the axis of the shaft and the piston of the press.

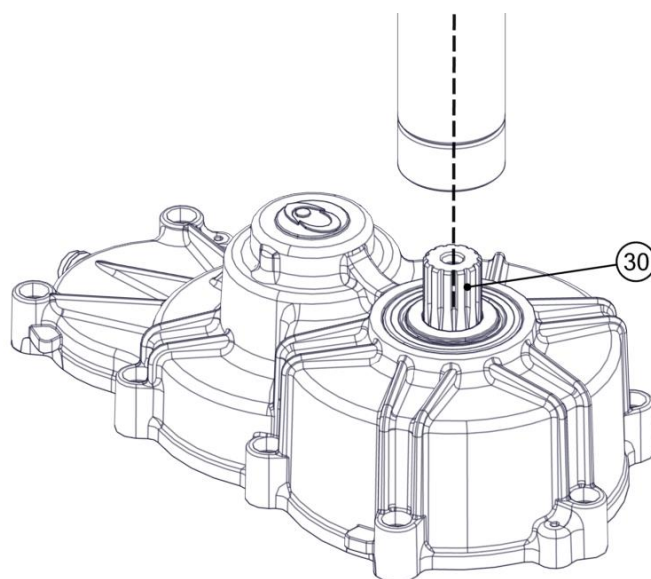
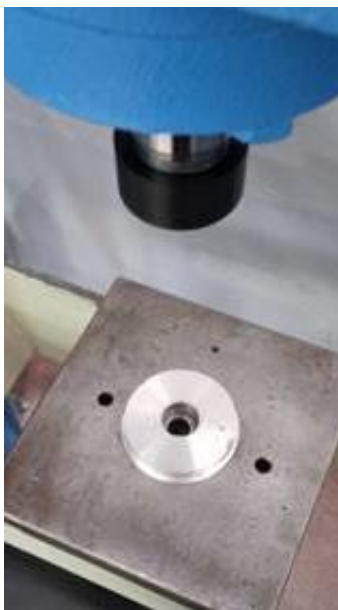



Non-coaxial pushing of the hub onto the shaft can cause irreparable damage to the parts.



Replace the propeller hub (29) each time it is disassembled.

Heat the propeller hub (29) to 200 °C and place it on the propeller shaft (30) making sure to match the gearings.



Handle using thermal gloves to protect hands from thermal risks.

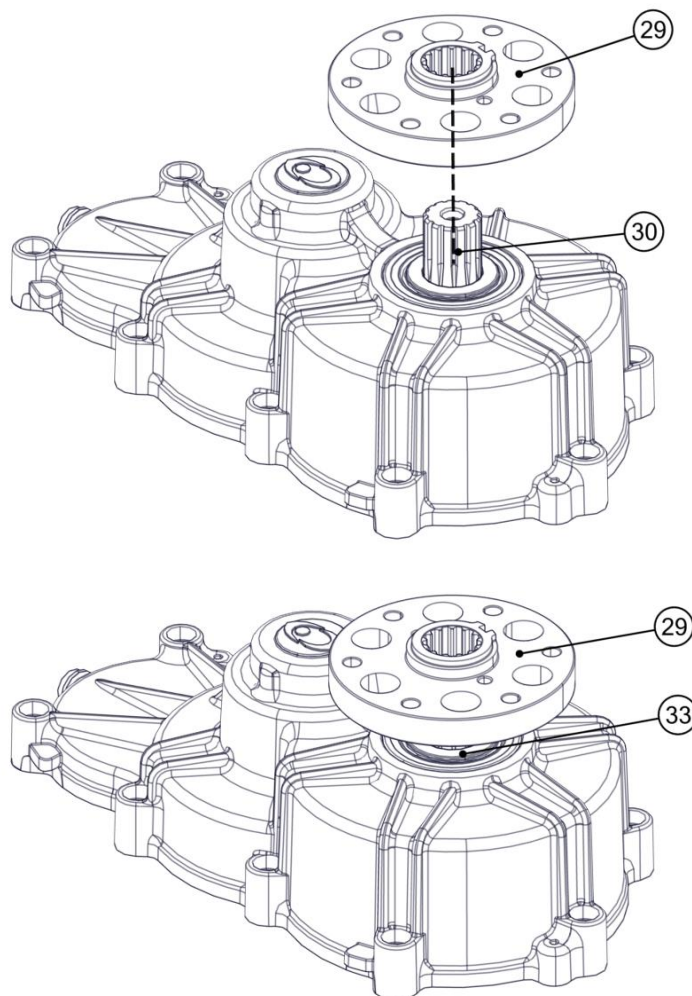

Push the hub (29) with a press on the surface highlighted in the figure to bring the hub (29) into contact with the bushing (33).

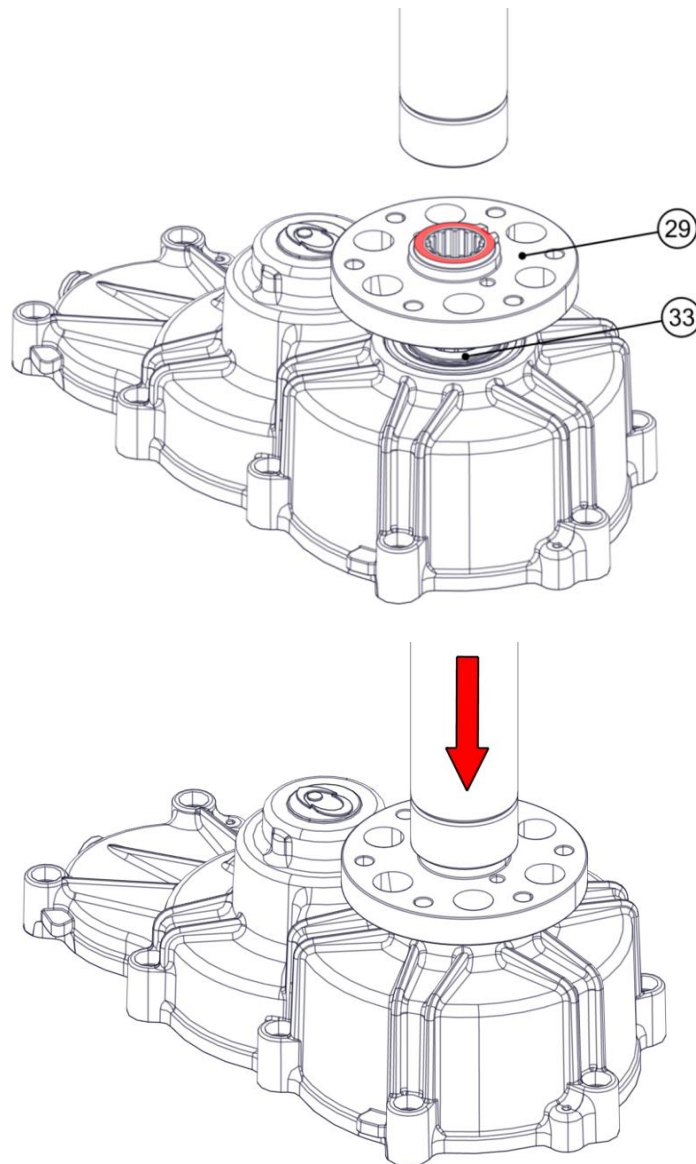

Do not apply a load exceeding 1000 kg to prevent damage to the propeller hub.

Insert a temporary left-hand screw M8 while the hub is still hot and tighten with the torque shown in the figure.

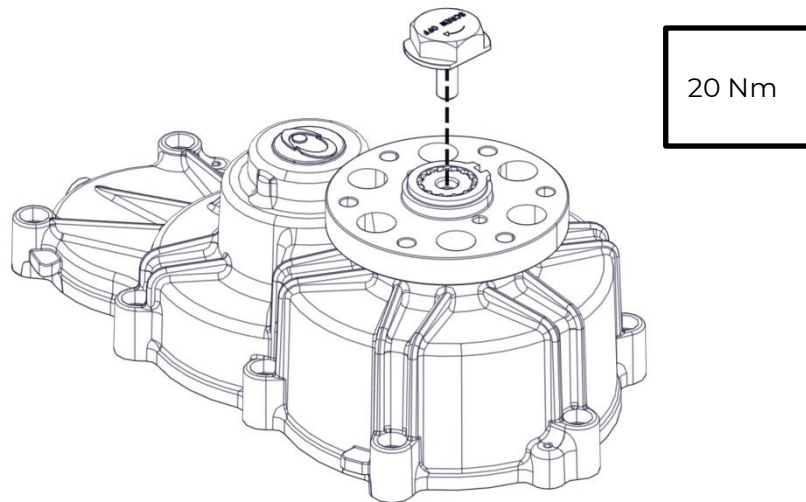

Wait a few minutes for the hub to cool before continuing assembly.
When the hub reaches the room temperature, remove the temporary left-hand screw M8.



Add threadlocker (recommended Loxeal 55-03/Loctite 243): insert it into the propeller shaft (29) threaded hole. Hardening time of the threadlocker: 3 hours.



Replace the anti-unscrewing washer (28) each time it is disassembled.

Insert the anti-unscrewing washer (28) and left-handed screw M8 (27)

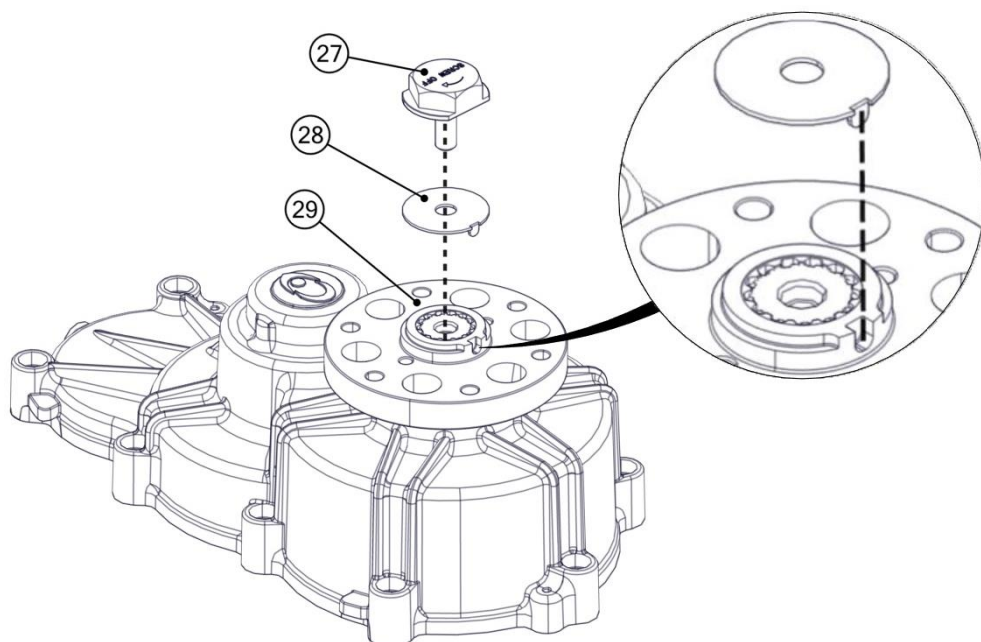

Use the propeller hub locking tool (25) [ACCI10] and tighten with the torque shown in the figure.

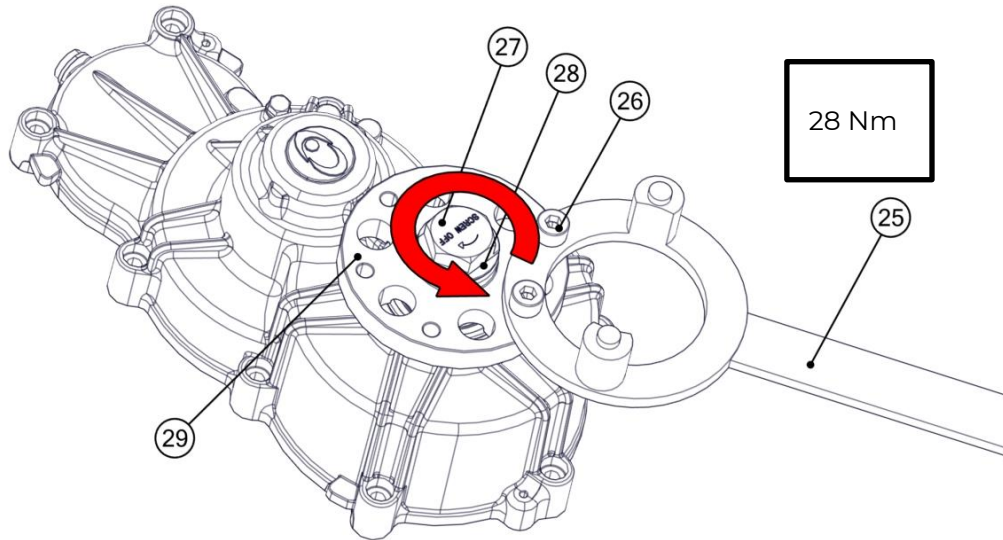

Bend the anti-unscrewing washer (28) as shown in the figure to make it adhere perfectly to one face of the hexagon of the screw.



Heat the upper bearing seat to 120 °C and insert the propeller shaft bearing (24).

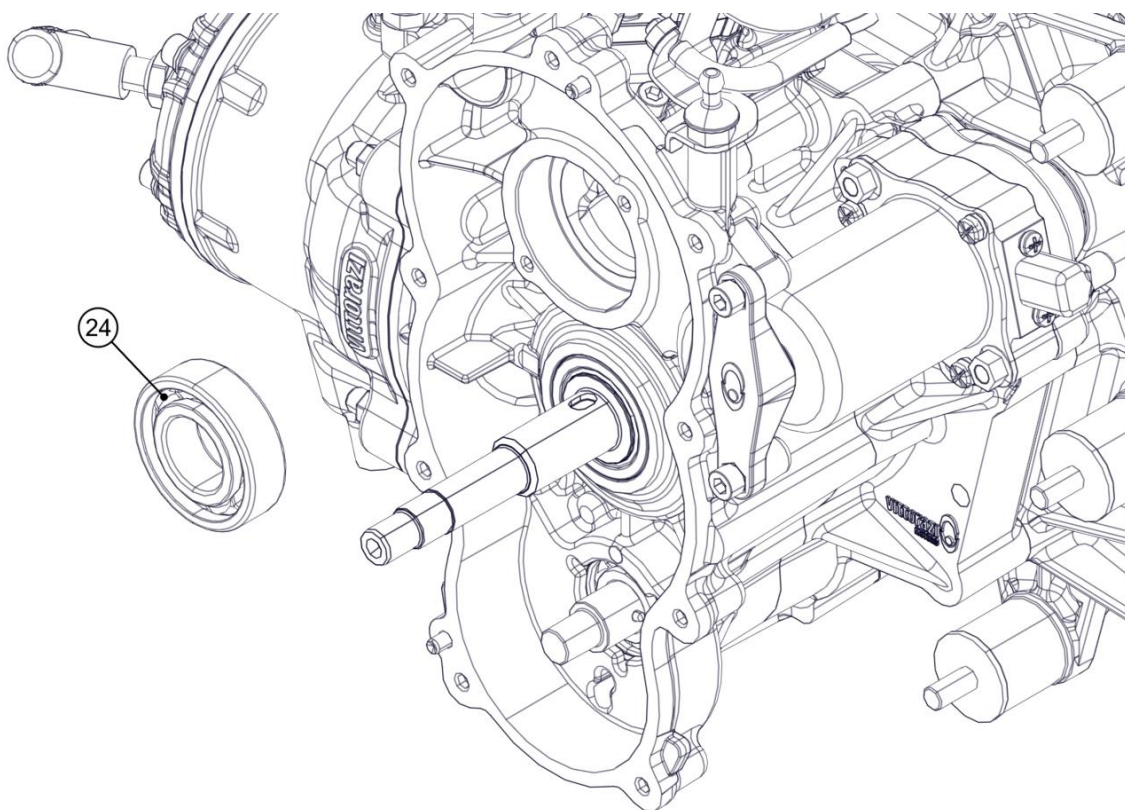

Insert the key (23) on the crankshaft (10).

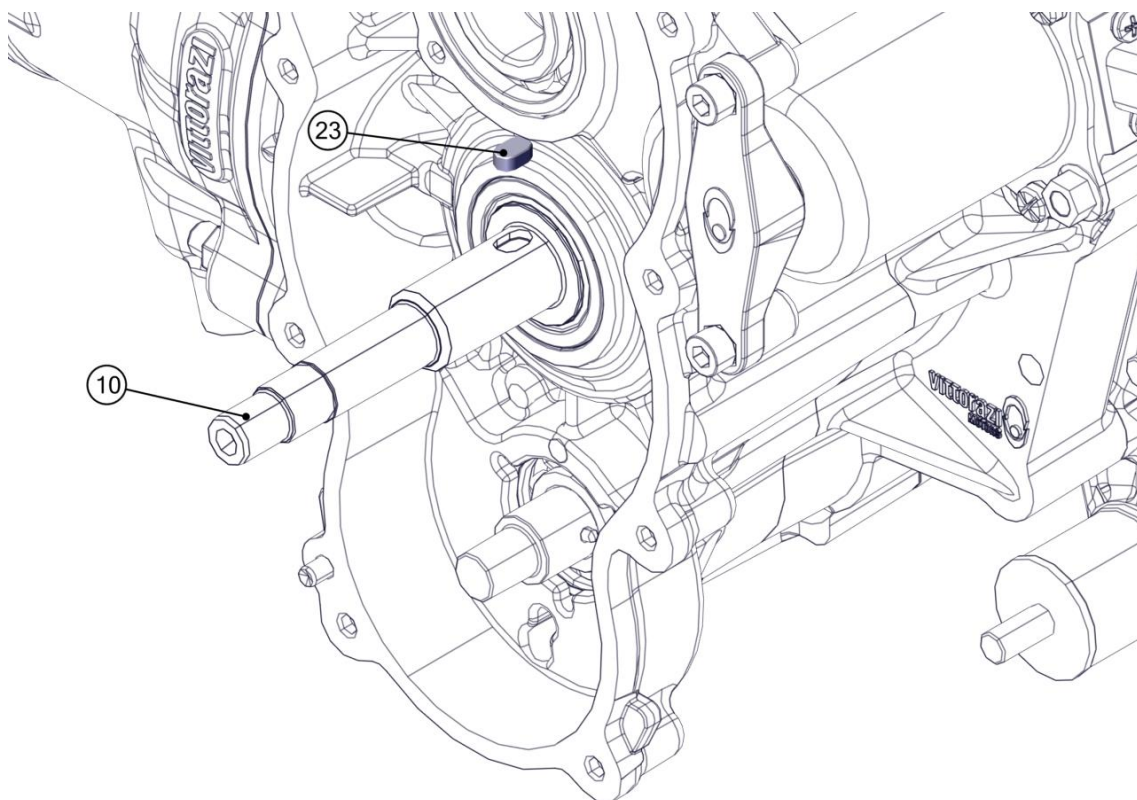

Insert the driving gear (22) on the crankshaft (10).

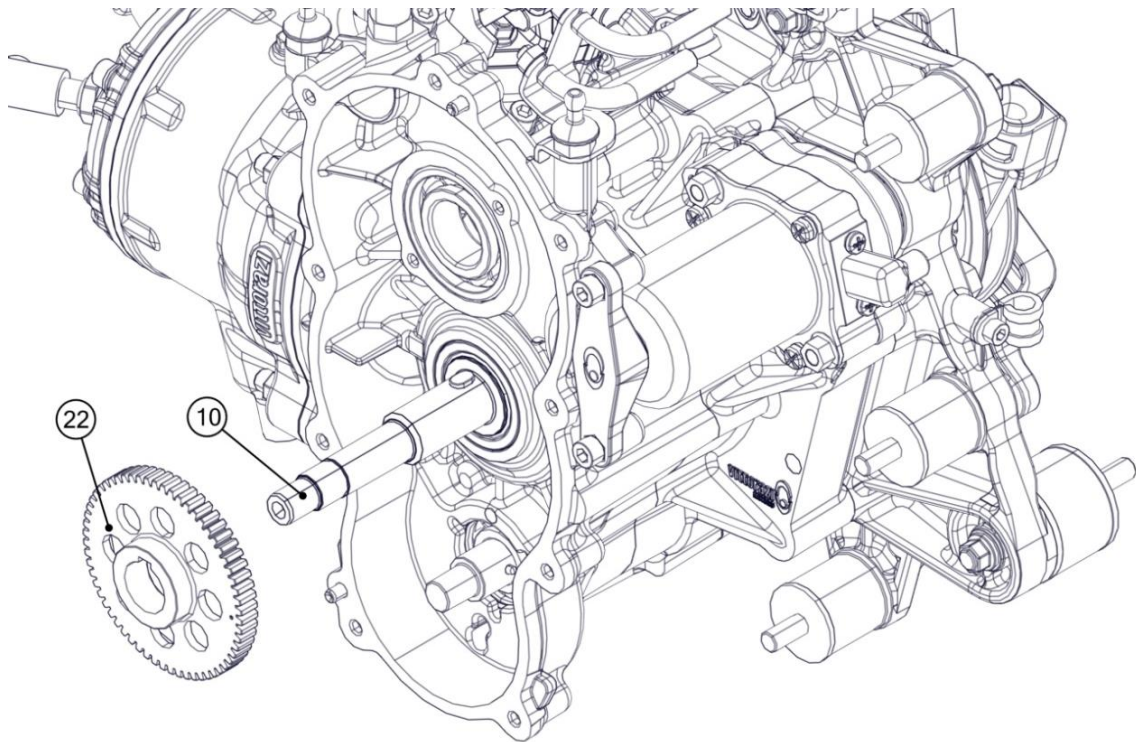

Turn the crankshaft to have the reference point (indicated by a dot near the tothing) at the bottom.

Turn the countershaft to obtain the alignment shown in the figure.

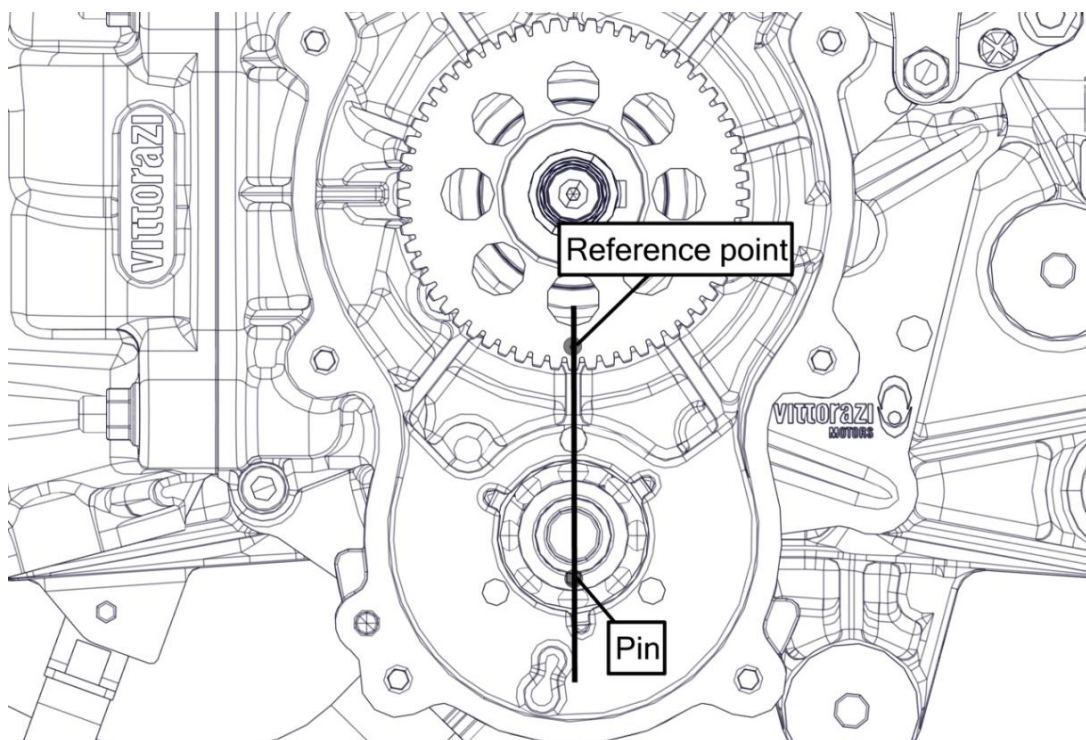

Check that the pin is on the countershaft before continuing with the assembly.

Insert the driven gear (21) on the countershaft (20) aligning the 2 points on the gears.

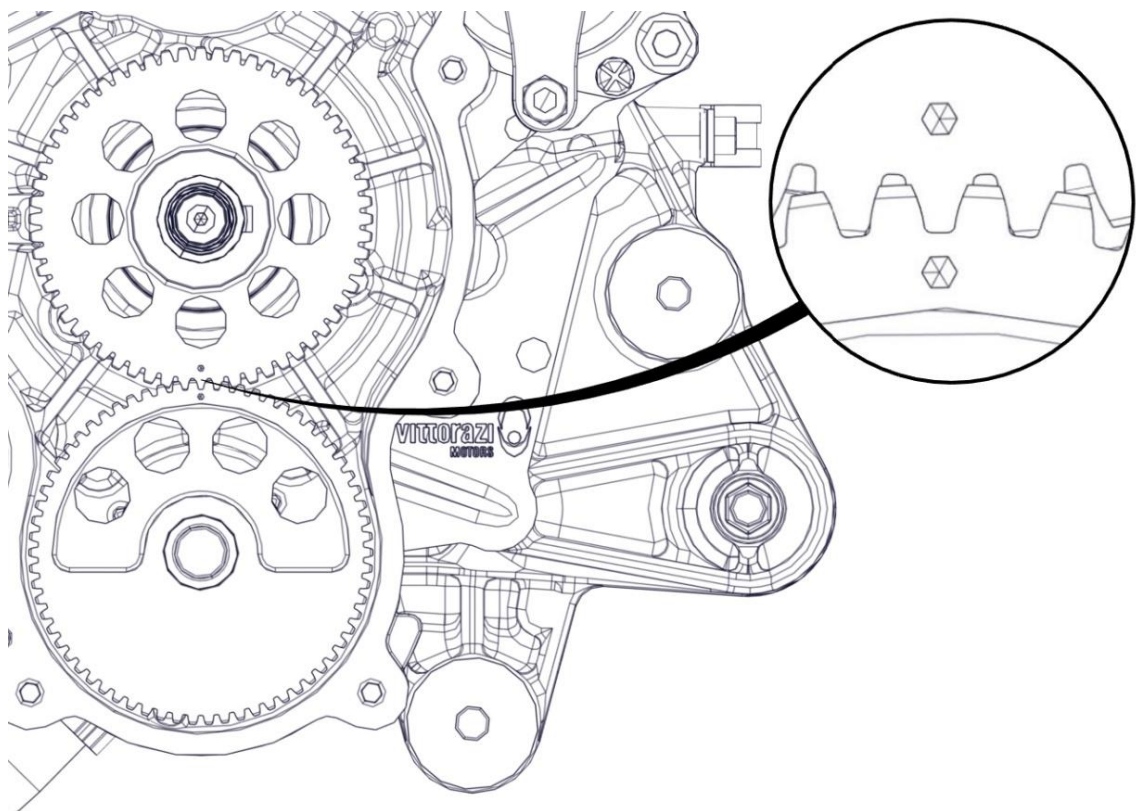
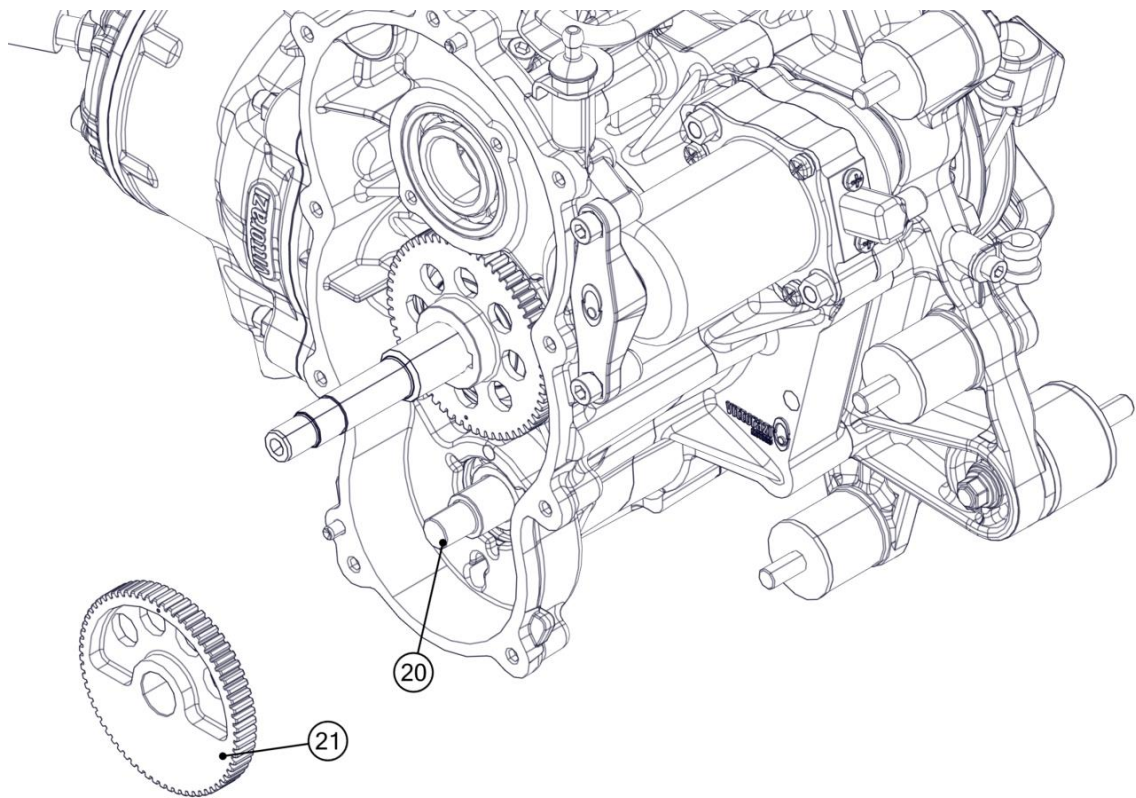

Insert the part A of the transmission locking tool [ACC112] into the holes of the 2 gearwheels.
The positioning of the transmission locking tool as shown in the figure confirms that the 2 gears have been mounted with the correct phase.

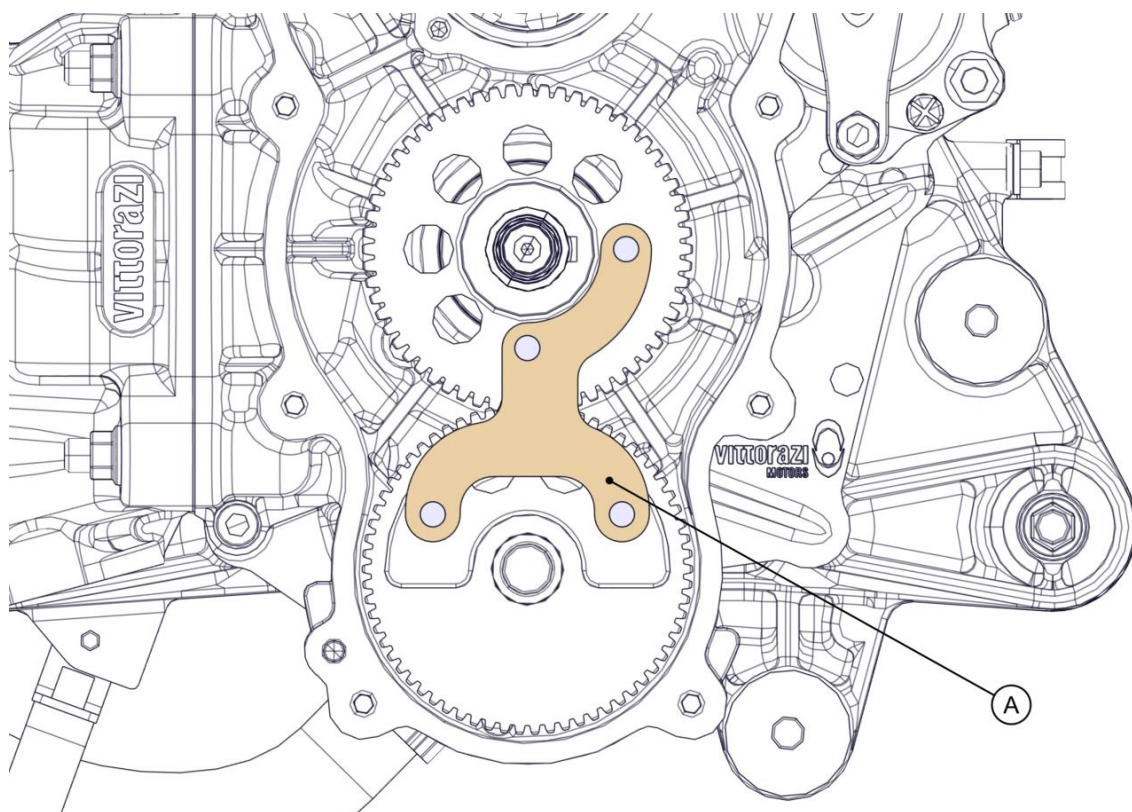

Insert the part B of the transmission locking tool as shown in the figure.
Secure the locking tool with the 2 Allen screws M6x20 (5).

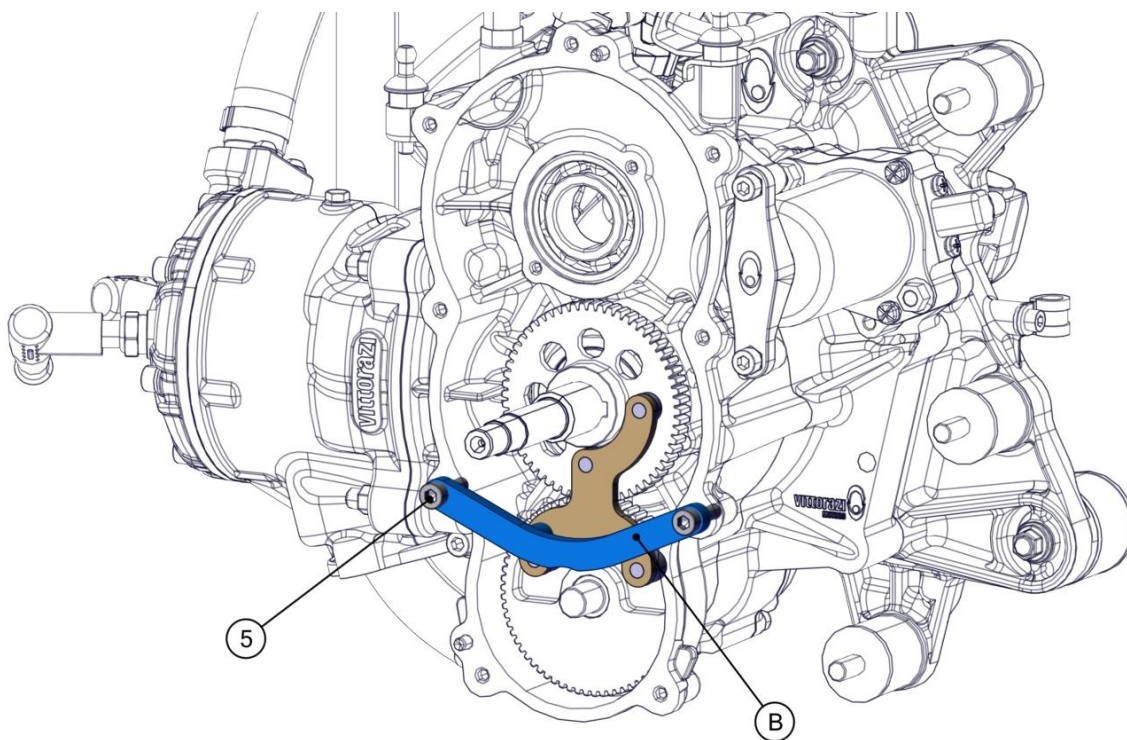



Replace the washer (19) each time it is disassembled.

Insert the nut M12x1,25 (18) with the washer (19) on the countershaft (20) and tighten with the torque shown in the figure.

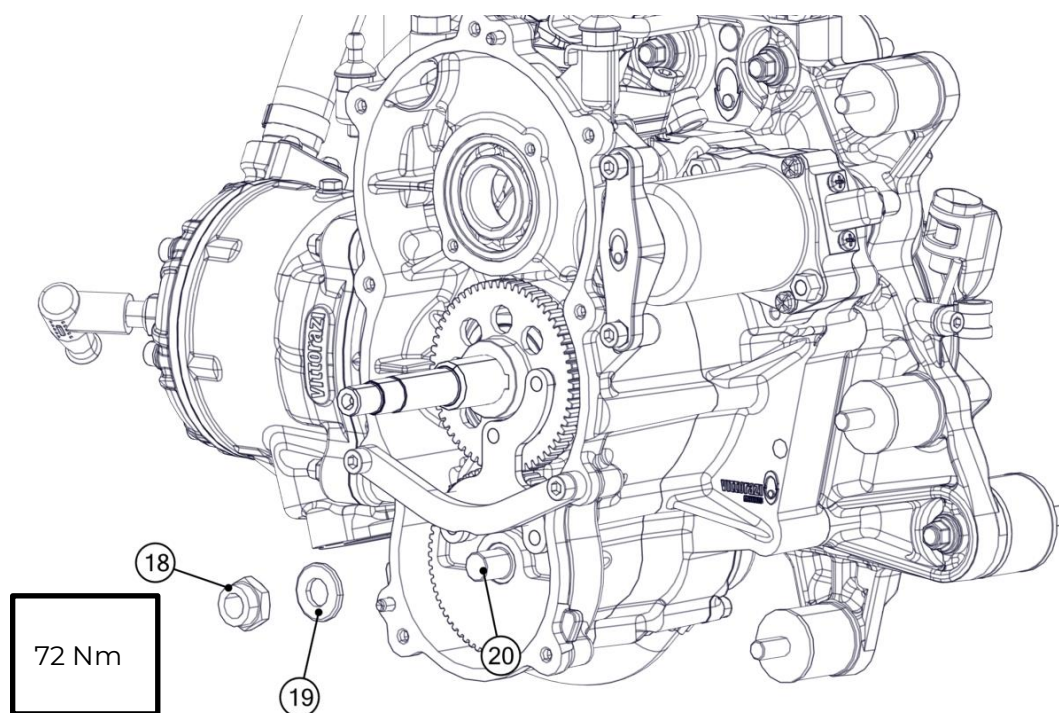

Insert the clutch plate (14), the 3 Torx screws M5x14 (12) on the clutch (13) and tighten with the torque shown in the figure.

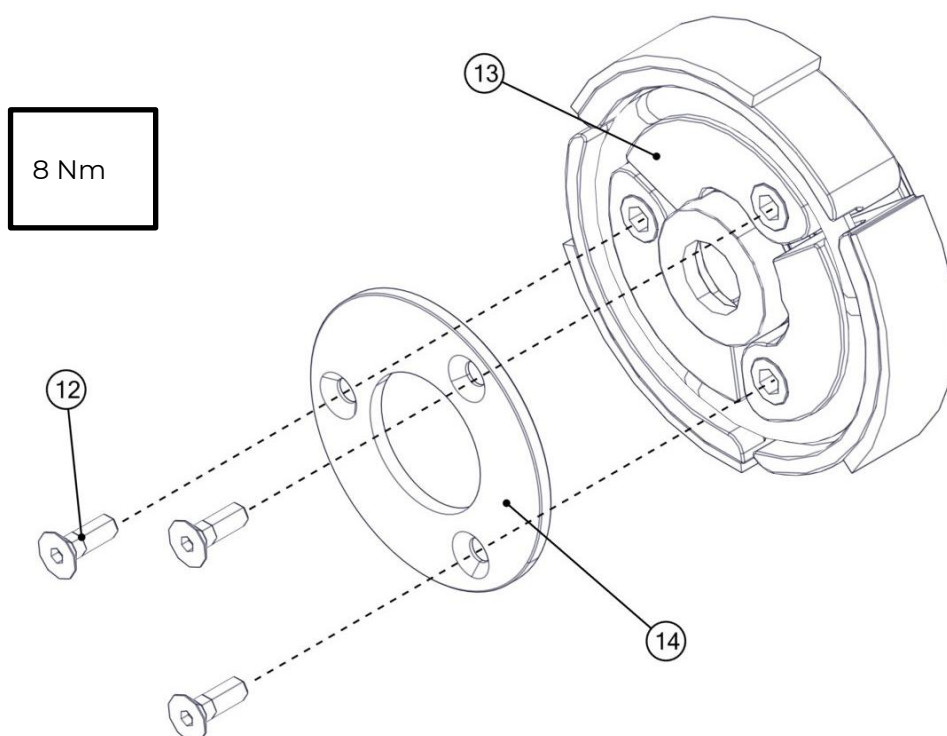



Before fitting the new clutch, carry out the operations described on this page.

Provisionally position the old clutch, without the compensating ring, on the crankshaft until it is in contact with the gearwheel.

Measure the distance between the clutch plane (A) and the transmission cover separation plane (B) as shown in the figure.

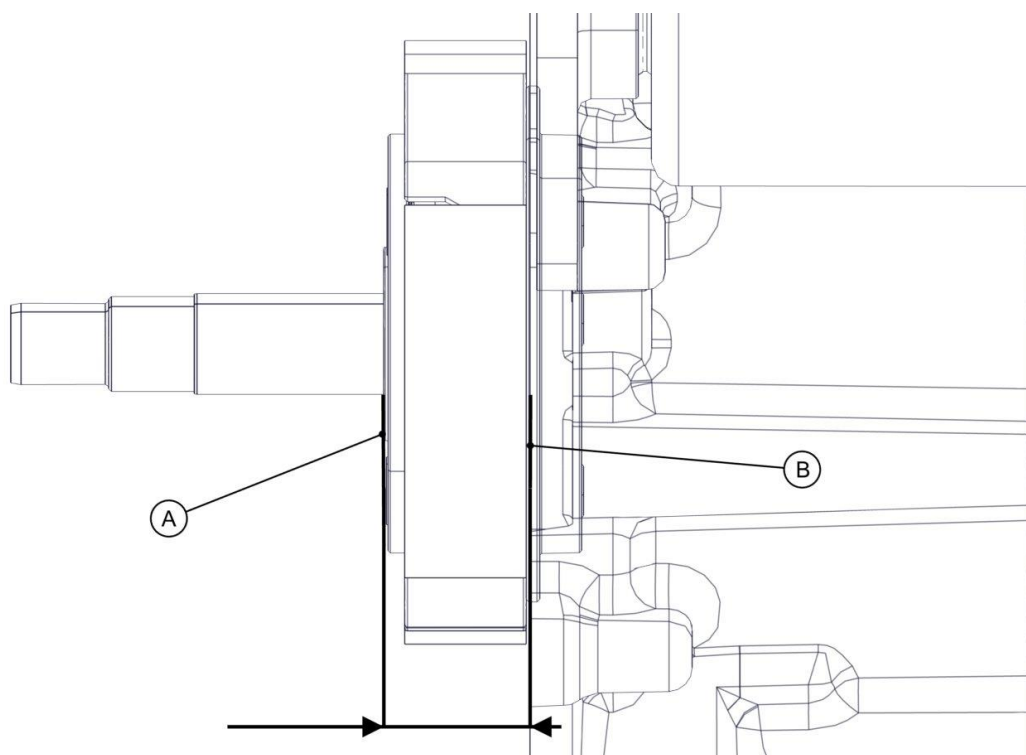
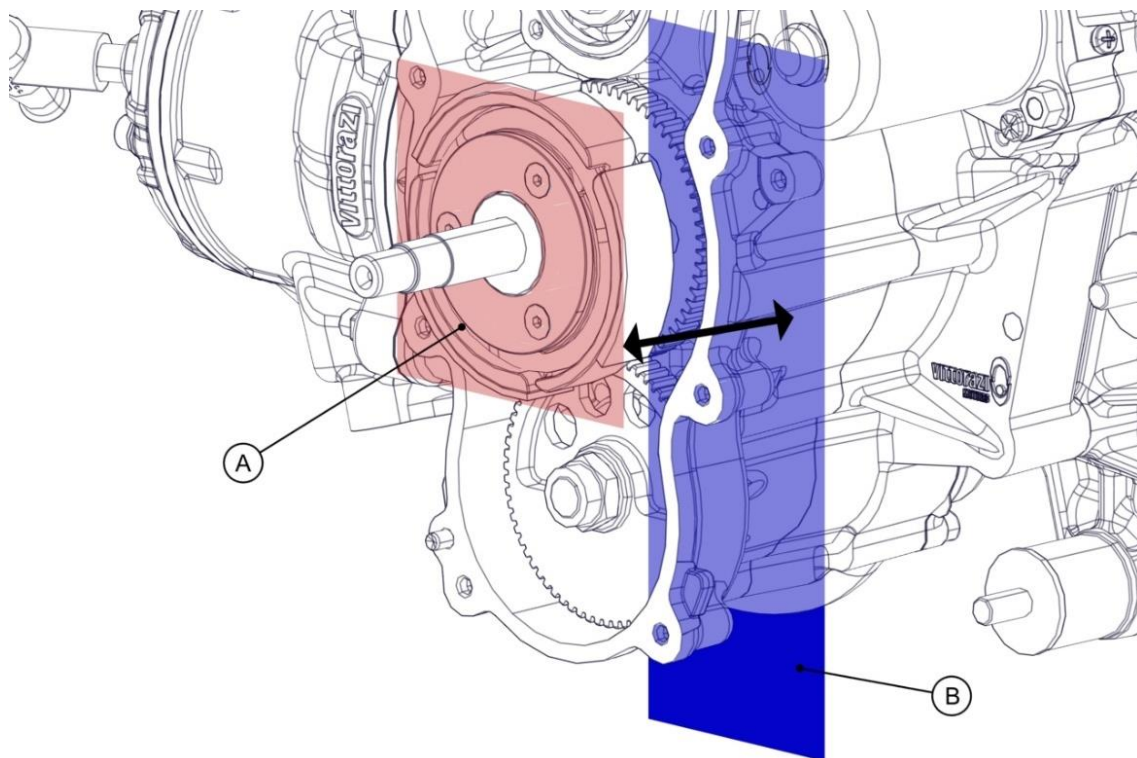

Remove the old clutch.



Replace the compensating ring (37) each time it is disassembled.

Insert the compensating ring (37) into the clutch (13) by positioning the ring opening 180° from the clutch groove (highlighted in the figure).

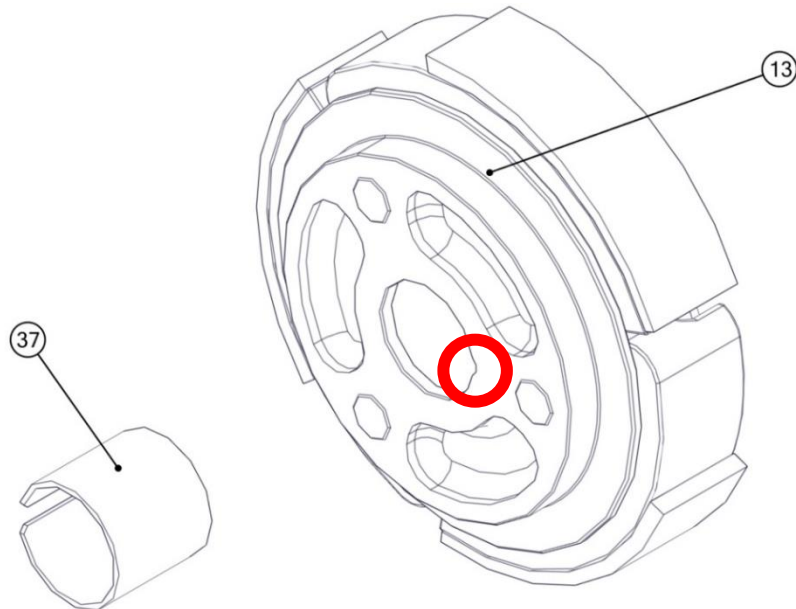

Lubricate the surface of the crankshaft.
Insert the clutch (13) on the crankshaft (10) without looking for a phase.

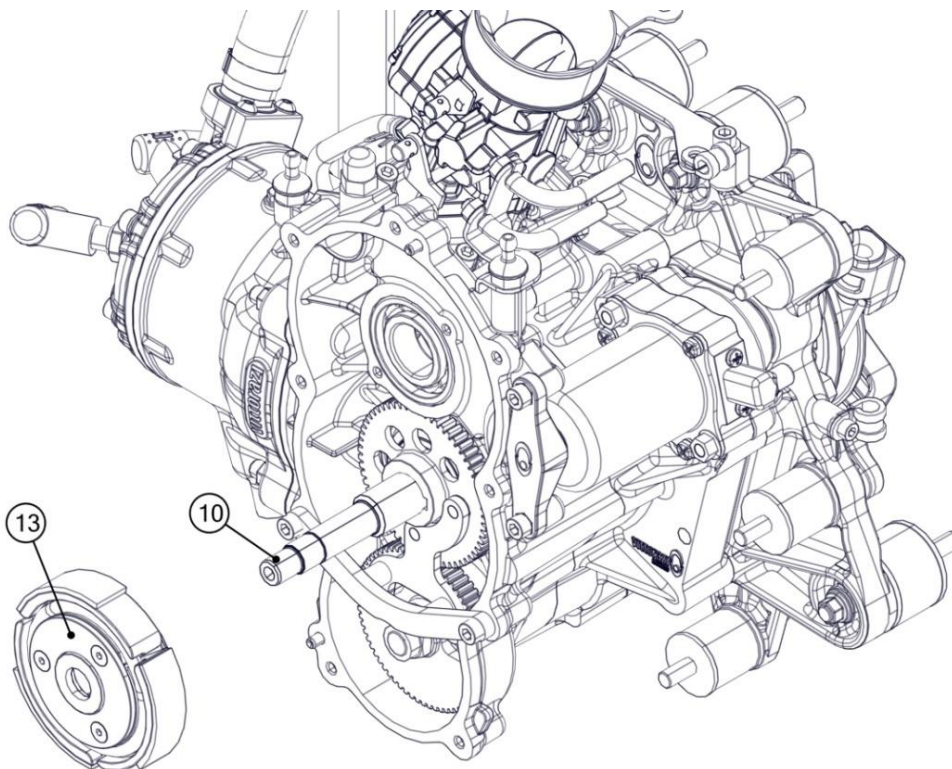

Prepare the clutch assembly tool [ACC115] as shown in the figure: screw part A completely onto part B.

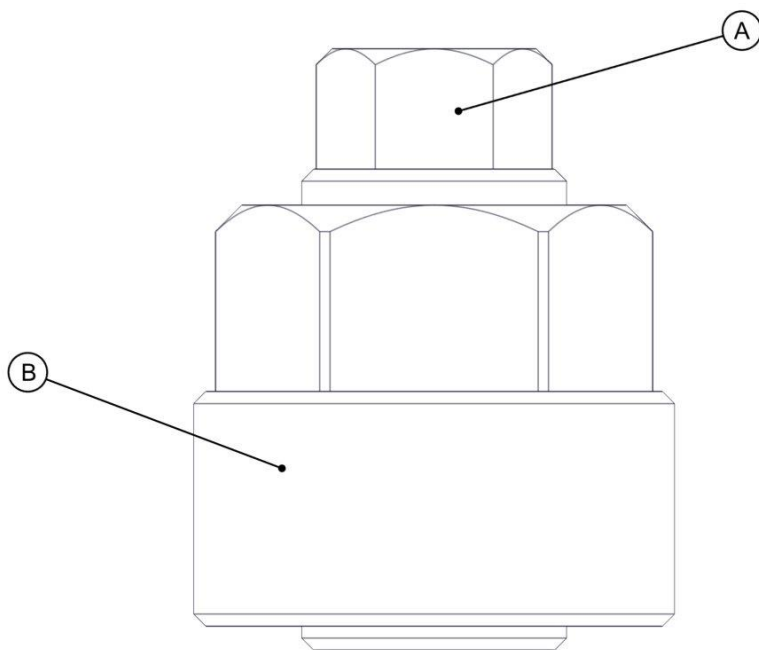

Screw part A completely onto the crankshaft with a 17 mm spanner. Turn the part B with a 32 mm spanner and apply the torque shown in the figure.

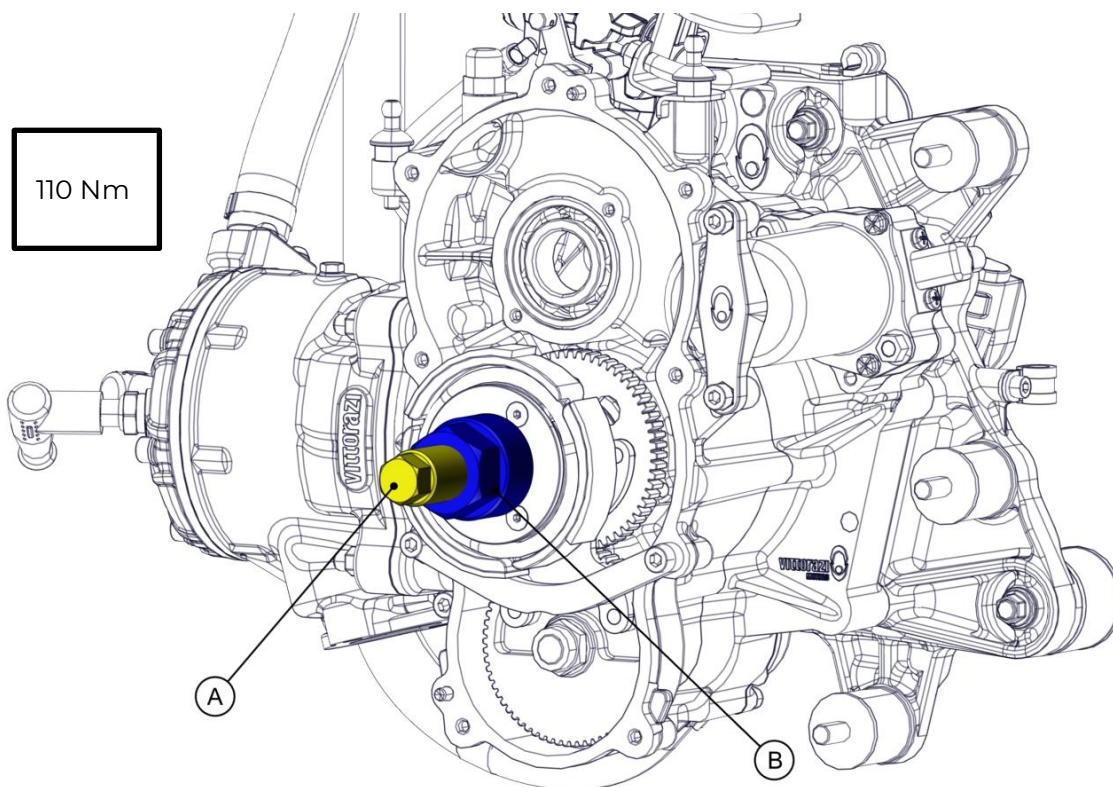

To remove the clutch assembly tool, unscrew both parts of the tool (A, B) at the same time.



Measure again the distance between the clutch and the transmission cover separation plane. Check that it coincides with the measurement taken previously.

Lubricate the roller bearings, the clutch bell and the surface of the crankshaft with transmission oil.

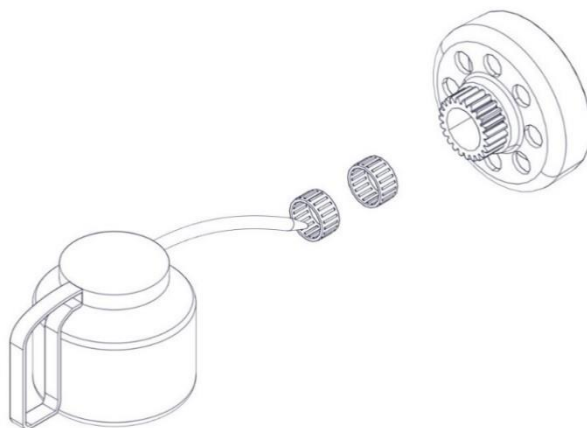

Insert the bushing (11) and the 2 roller bearings (9) on the crankshaft (10).
Insert the clutch bell (8).

Insert the nut M14x1,5 (6) with the washer (7) and tighten with the torque shown in the figure.



Use a torque wrench, do not use a pneumatic impact screwdriver.

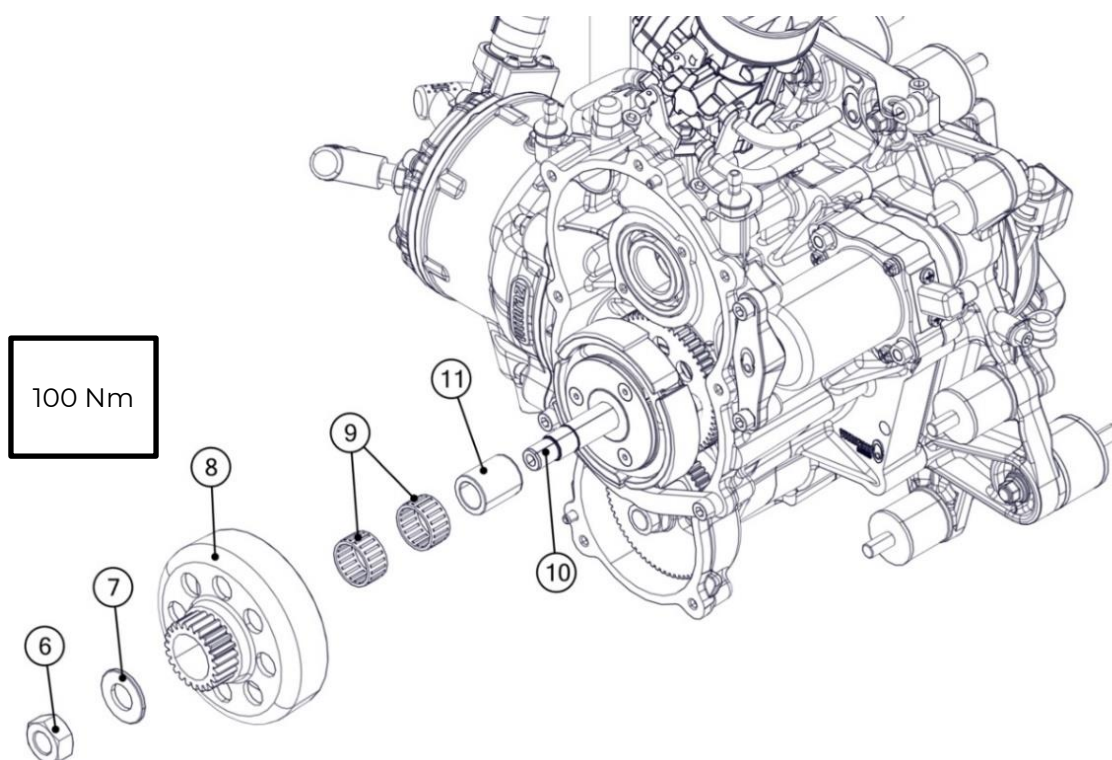

Remove the 2 Allen screws M6x20 (5).
Remove the part B.
Remove the part A.

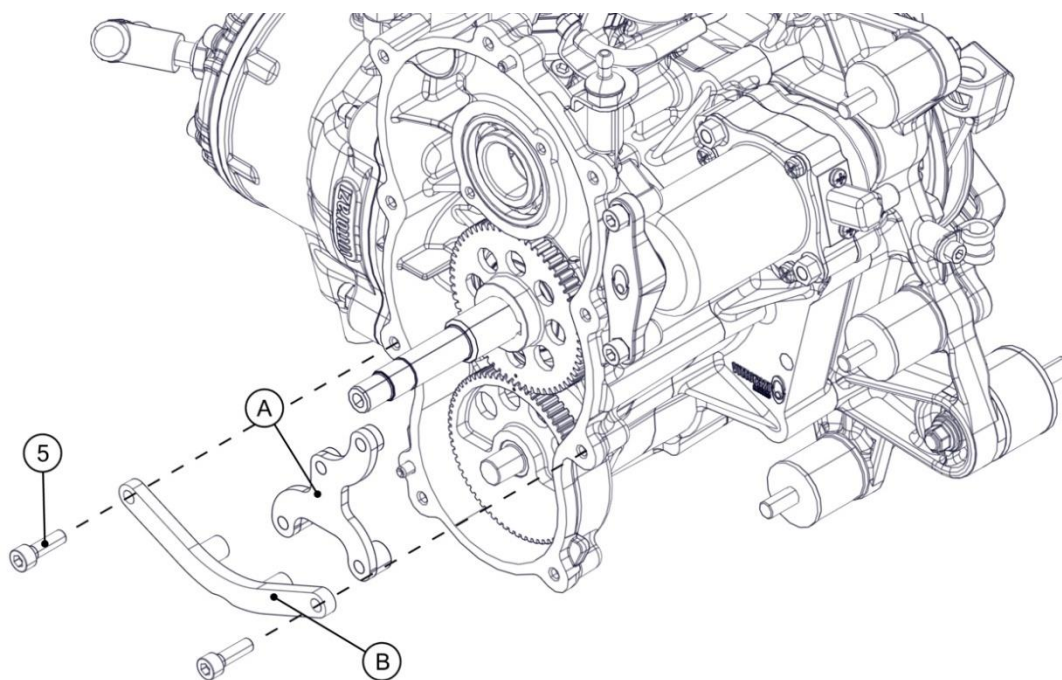

Replace the gasket (4) each time it is disassembled.

Place the gasket (4) on the 2 pins (38).
Insert the previously assembled transmission cover (2).

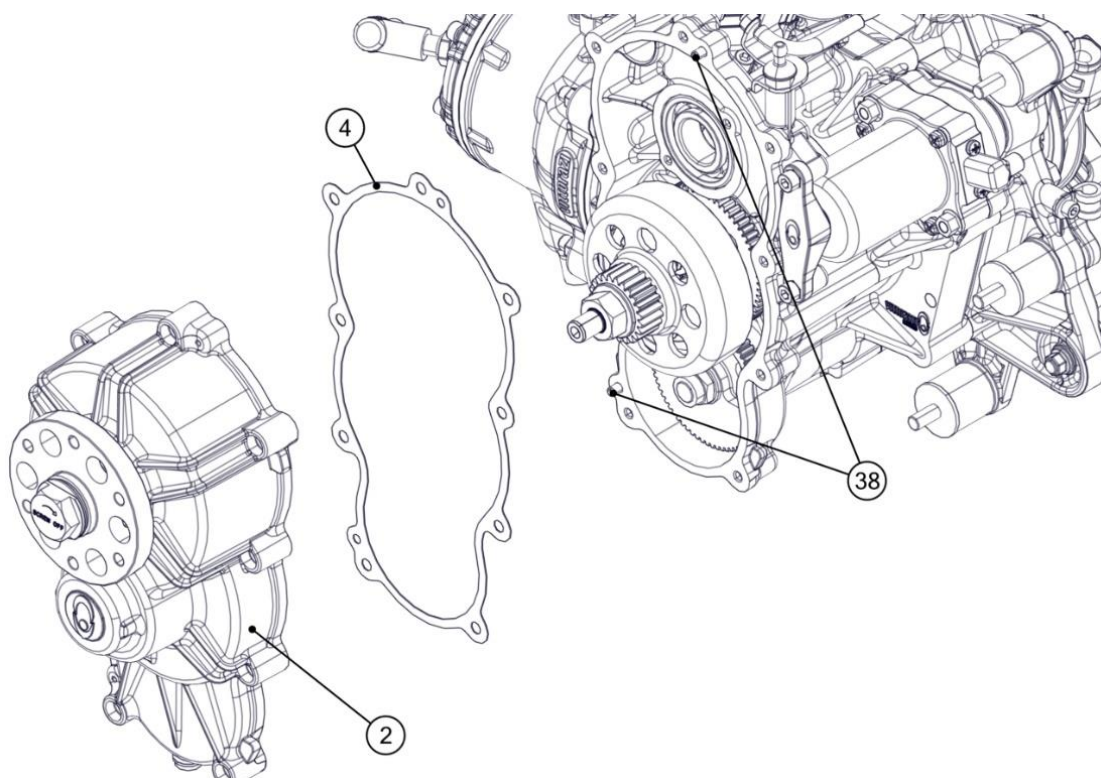

Insert and pre-tighten alternately the 2 highlighted Allen screws M6x30.

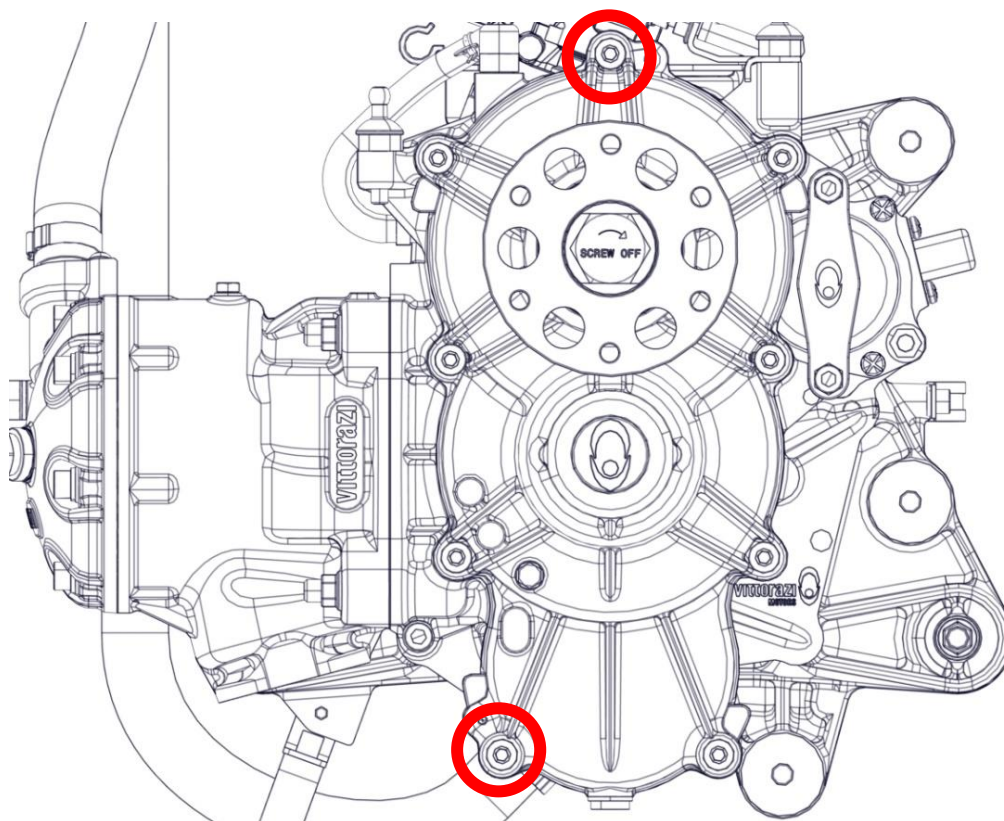

Insert the remaining 7 Allen screws M6x30 (1) into the cover (2).

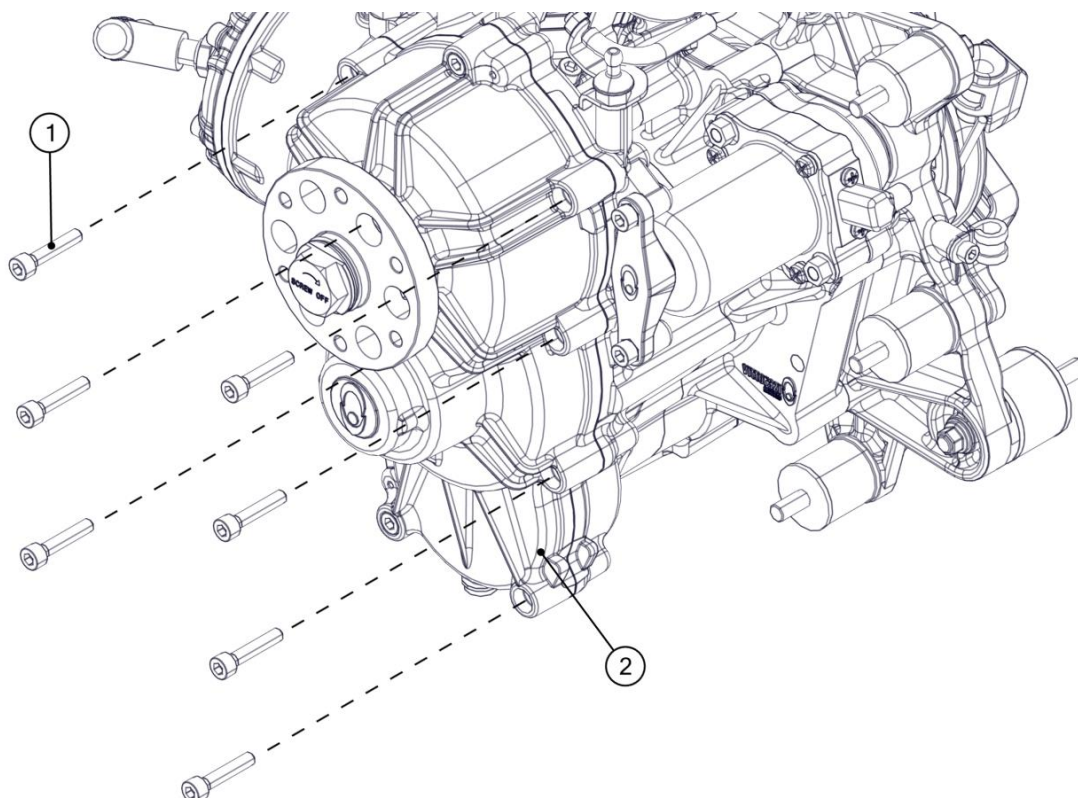

Pre-tighten progressively, then tighten in the order and with the torque shown in the figure.

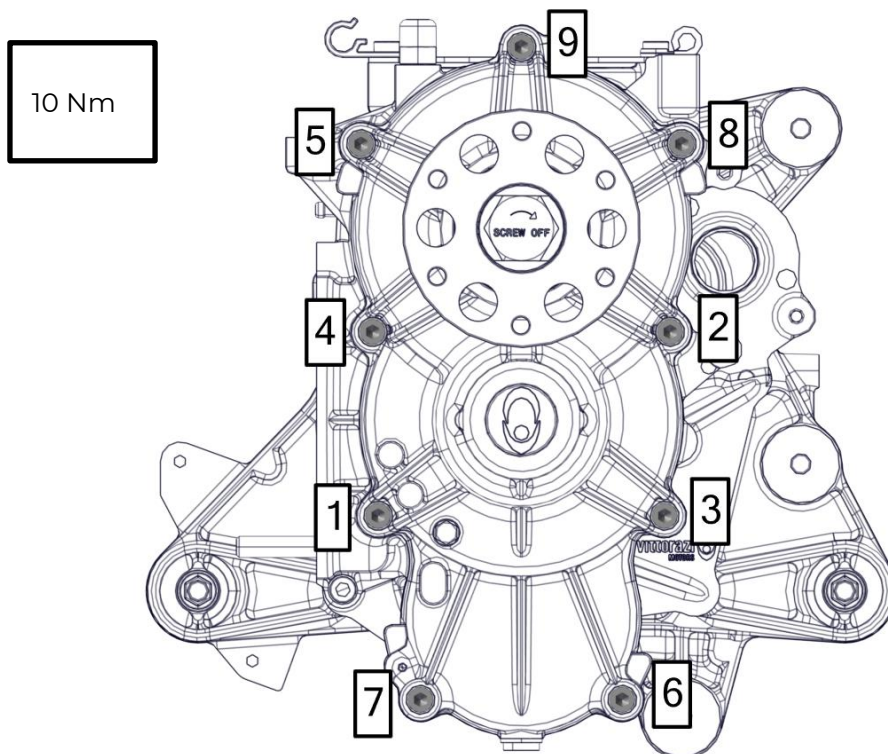



Check that all screws are tightened correctly in clockwise order.



After assembly, fill the transmission with oil.

3.14 Piston, cylinder, head

 Components to replace		Time limit
	Self-locking nuts M8* (M019)	200 h
	Gaskets* (C014, C016)	200 h
	Piston (C010) includes: pin (C011), circle clips (C012), piston rings (C013)	200 h
	Roller bearing (C009)	200 h
	Cylinder (C015)	on condition
 Special tools	Pin (ACC116).	
 Values	Self-locking nuts M8: 17 Nm. Screws M6x30: 10 Nm. Screw M5x10: 3 Nm	

*Always replace it when disassembled.

3.14.1 Piston, cylinder, head disassembly



Before disassembling the cylinder unit, remove the spark plugs (3.2 Spark plugs), the exhaust system (3.7 Exhaust system) and the coolant (3.8 Cooling system).

In order to disassemble cylinder/head/piston it is not necessary to disassemble the thermostat and the connector to the cooling system

Remove the clamp on the pipe exiting the head.
Remove the pipe from the head.

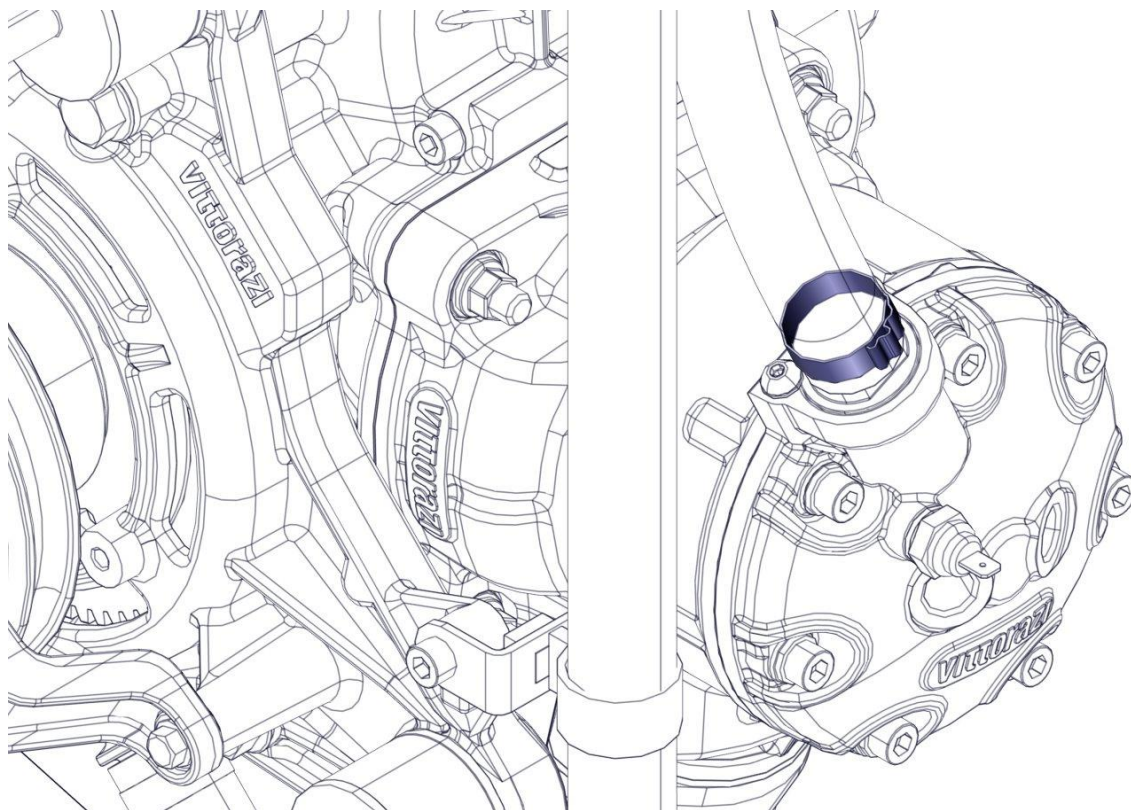

Remove the 2 Allen screws M5x10 (1) with washers (2).
Remove the connector (3), the O-ring (4) and the thermostat (5).

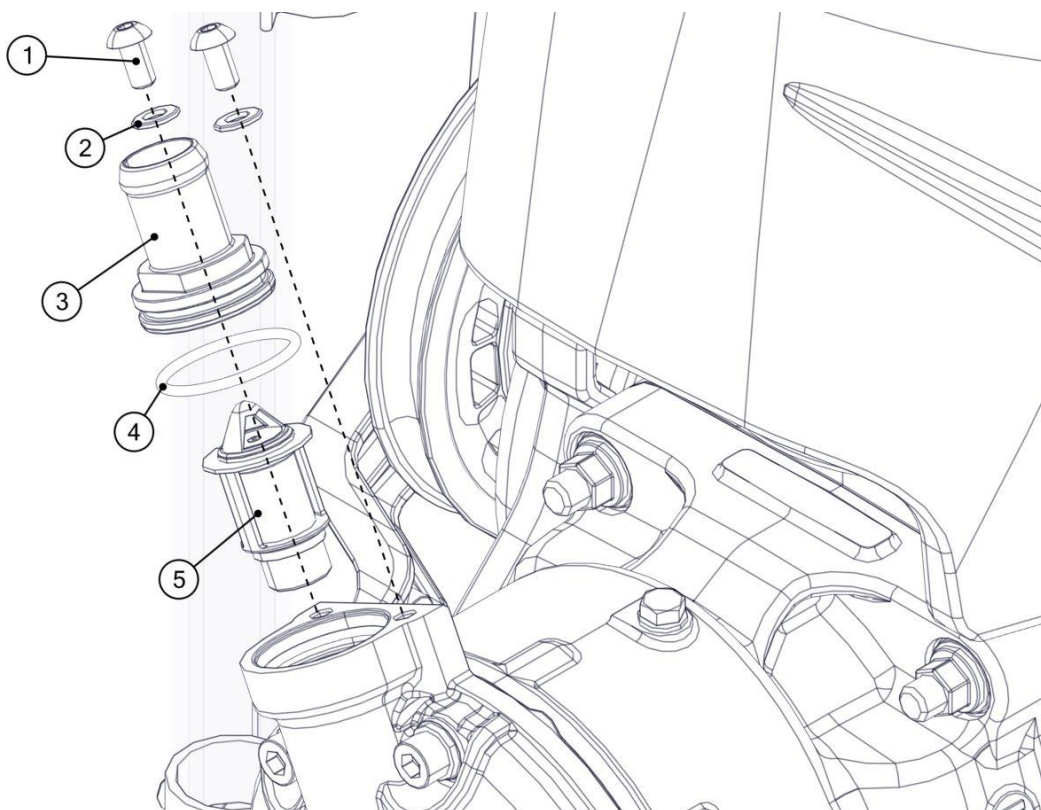

Remove the 7 Allen screws M6x30 (6) with washers (7) from the engine head (8).
Remove the head (8) and the head gasket (9).

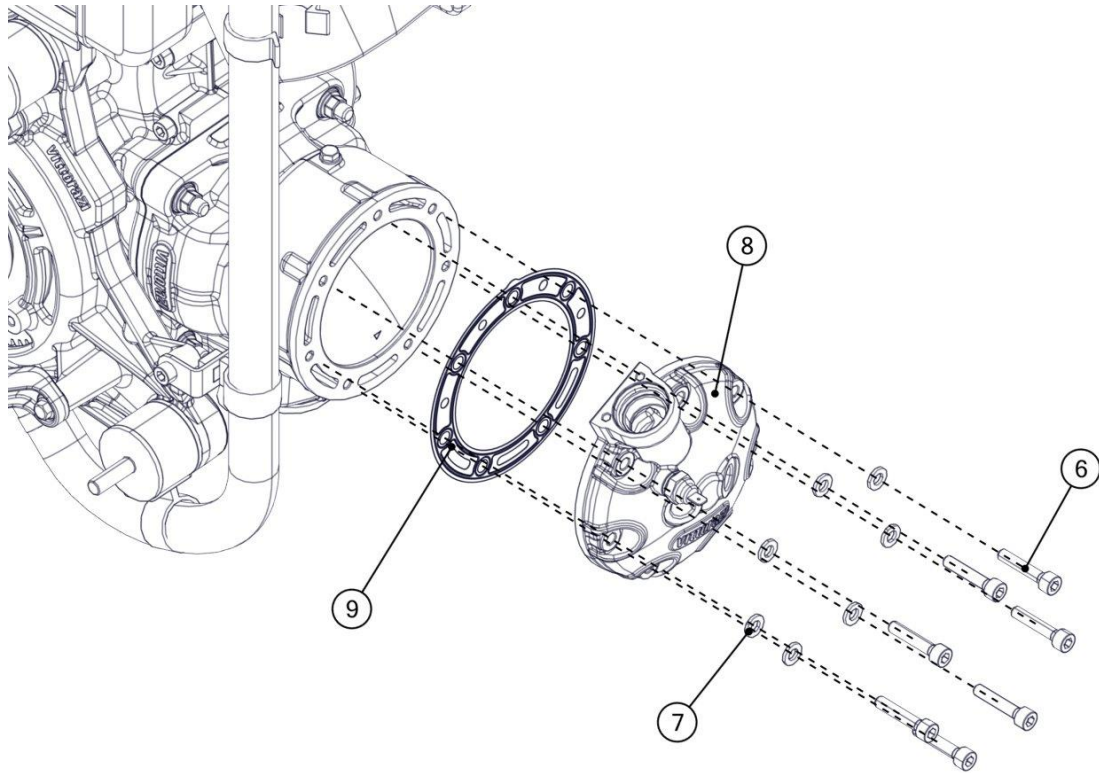

Remove the 4 self-locking nuts M8 (10) with washers (11) from the engine studs (14).
Remove the cylinder (12) and the cylinder base gasket (13).

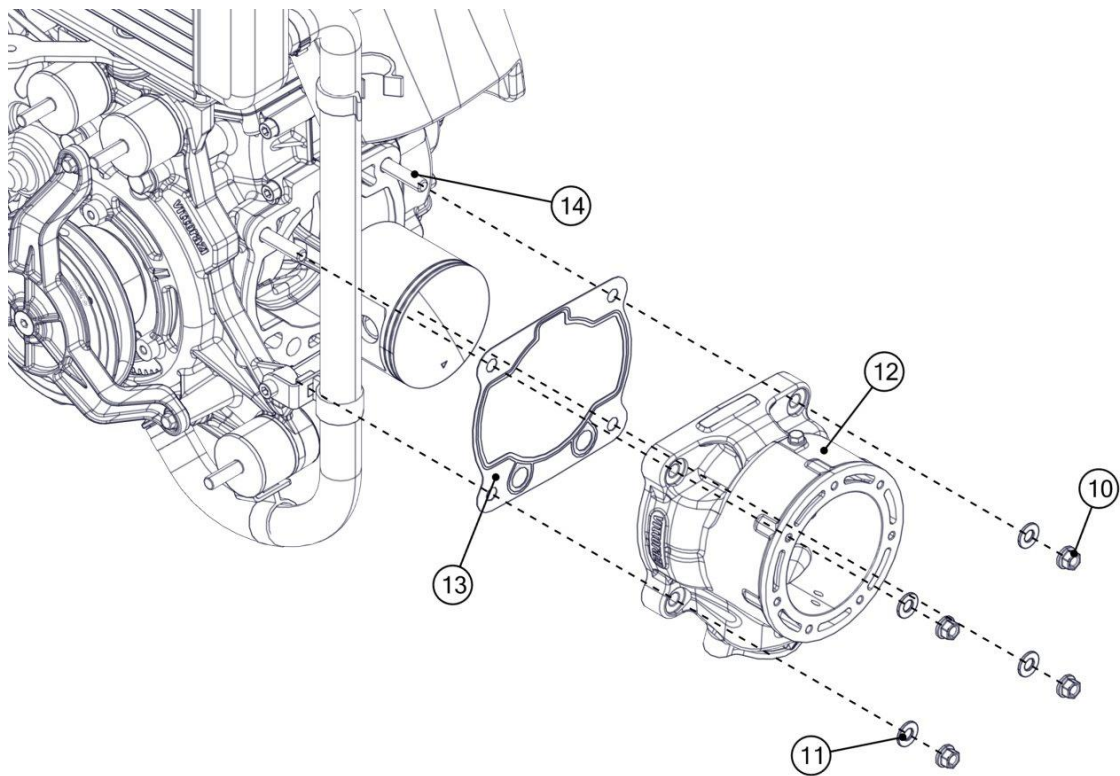



Close the inside of the crankcase with paper to prevent foreign bodies from accidentally falling into the engine.

Remove the circle clip (15), the pin (16), the piston (17) and the roller bearing (18).

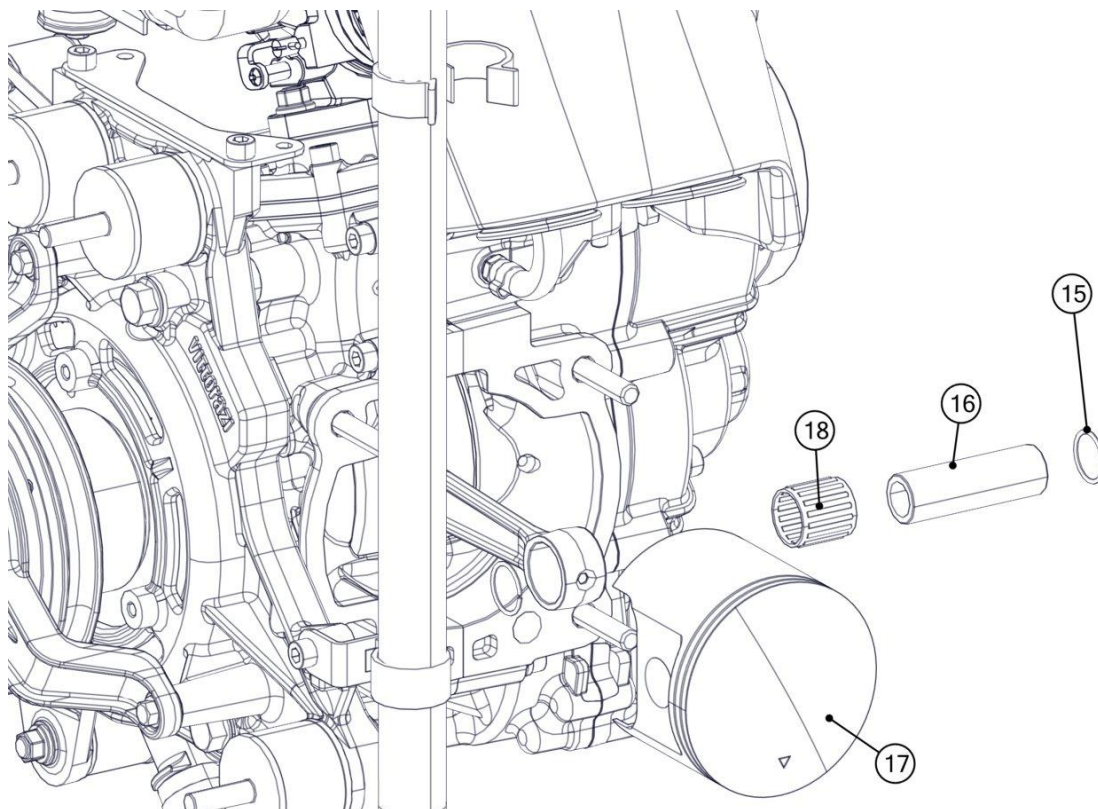

Remove the 2 piston rings (19) and the circle clip (15) from the piston (17).

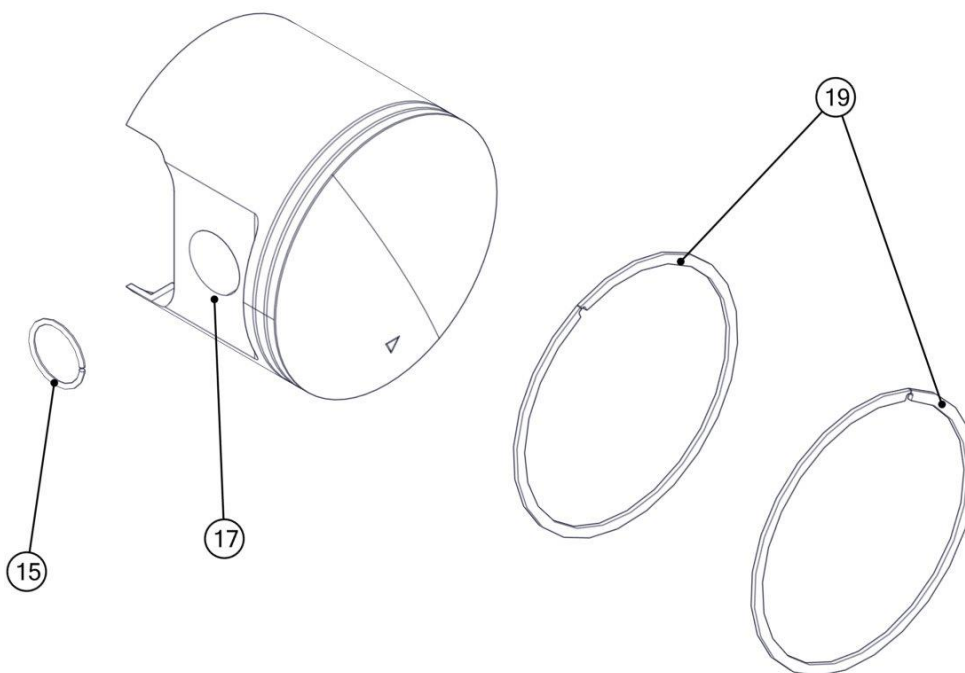

3.14.2 Piston, cylinder, head maintenance



Do not use abrasive tools and corrosive liquids that may damage the surface.

Carefully remove gasket residues from the cylinder and the crankcase.

Thoroughly clean the piston crown, the piston grooves, the exhaust port on the cylinder and internal surface of head.

Clean only the 2 decompression holes on the cylinder with a 3 mm drill bit, taking great care.

Immerse the piston, cylinder and head in an ultrasonic bath containing cleaning liquid for aluminum.

The cylinder and piston belong to different selection classes according to tolerance.

Check the selection class engraved on the piston.

Measure the diameter of the piston 10 mm from the base of the shell.

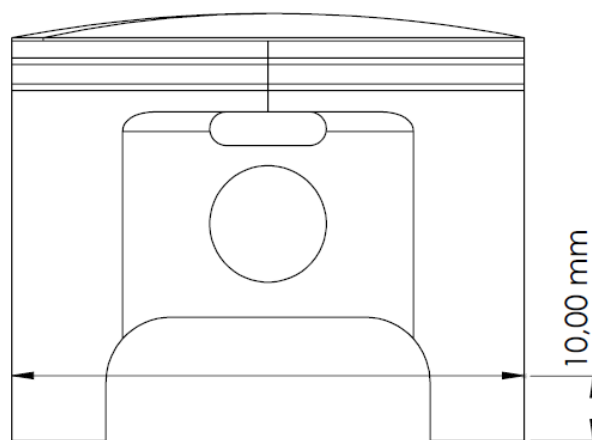

Measure the diameter of the cylinder 10 mm from the top.

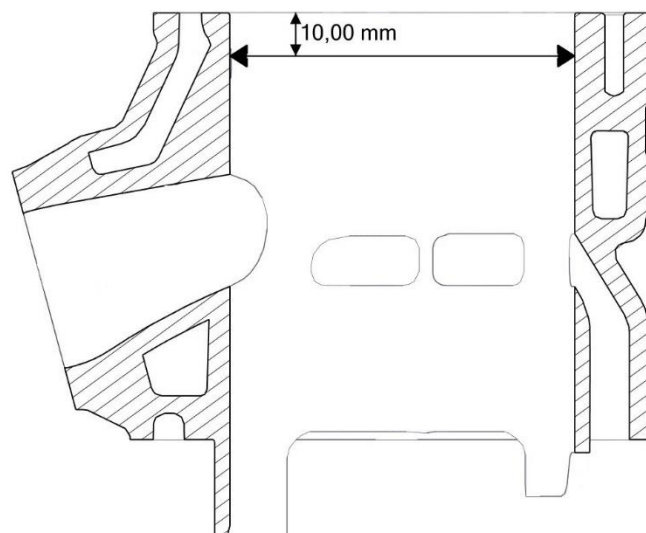

The table shows the cylinder, the piston sizes and the factory nominal clearance for new components.

Maximum clearance refers to worn components.

Selection	Cylinder ϕ^* (mm)	Piston ϕ^* (mm)	Factory nominal clearance* (mm)	Maximum clearance* (mm)
A	79,000-79,010	78,955-78,965	0,035-0,055	0,1
B	79,010-79,020	78,965-78,975		
C	79,020-79,030	78,975-78,985		

* at 20 °C



Determine the maximum clearance, if equal to or greater than the indicated value replace the piston and/or cylinder.

Check the piston and cylinder for signs of seizure, otherwise replace them. For routine maintenance, follow the table.

3.14.3 Piston, cylinder, head assembly



Replace the gasket (13) [C014] each time it is disassembled.
Insert the gasket (13) [C014] with the water passage holes at the bottom and on the side shown below.
Position the gasket as in the photo: the silicone profile on the gasket is on the cylinder side.

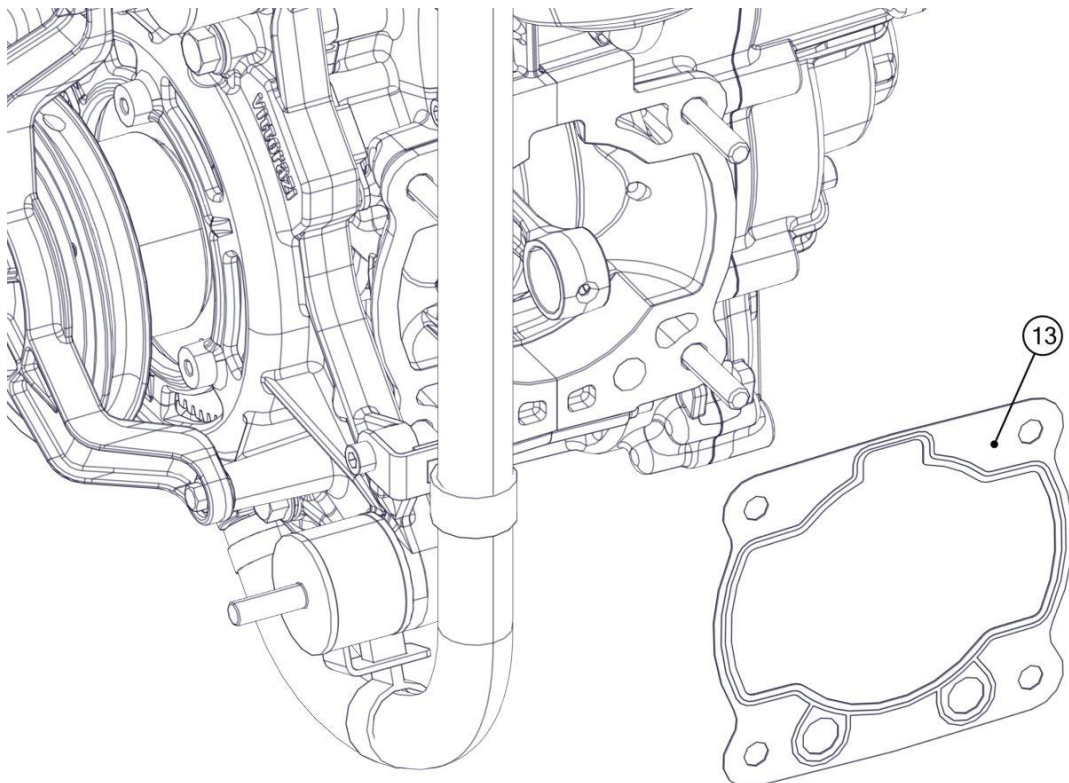

Oil the following components with the oil used for the mixture: the roller bearing (18), the pin (16), the piston rings (19) and the piston (17).



Insert the 2 piston rings (19) into the piston grooves (19), paying attention to the position of the 2 piston ring retainers.

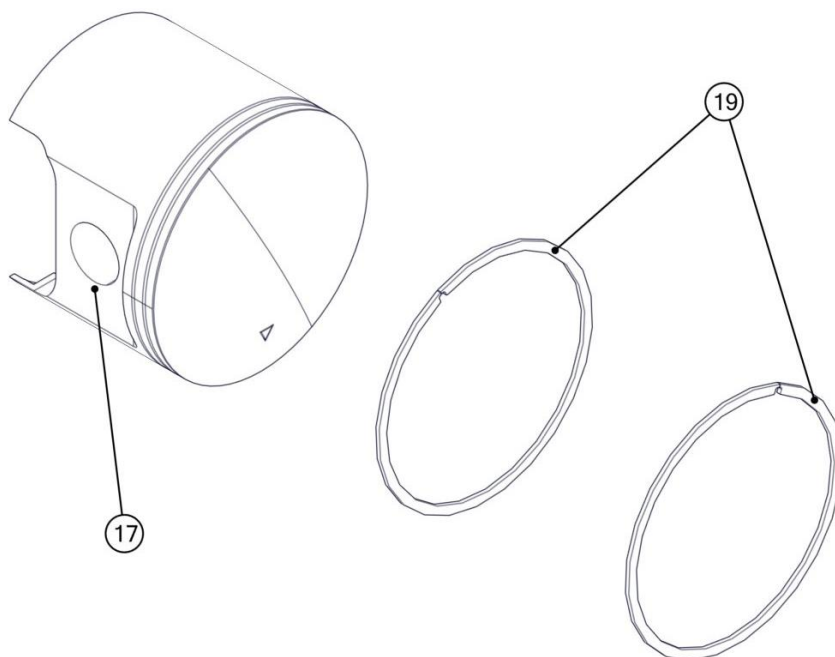

Insert a circle clip (15) on the piston (17) respecting the position shown in the photo.

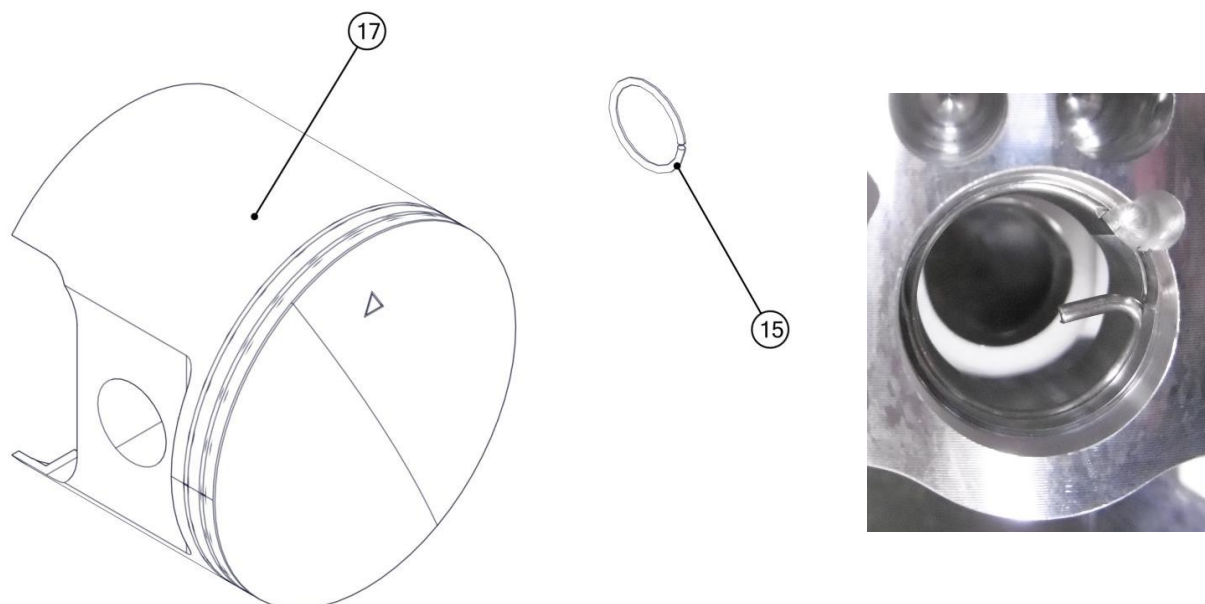

The triangle on the top of the piston indicates the exhaust side.

Insert the roller bearing (18), the piston (17), the pin (16) and the circle clip (15).

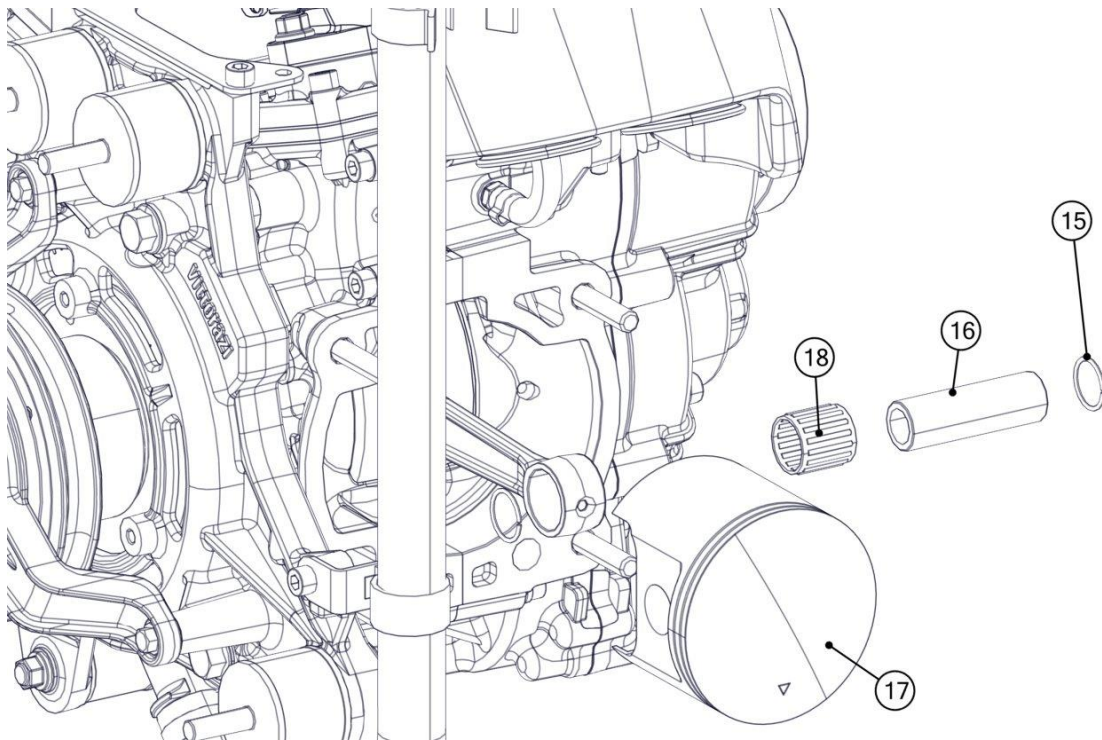

Replace the 4 self-locking nuts M8 (10) each time they are disassembled.

Insert the cylinder and the 4 self-locking nuts M8 (10) with washers (11) on the engine studs (14). Tighten the nuts progressively then cross-tighten with the torque shown in the figure.

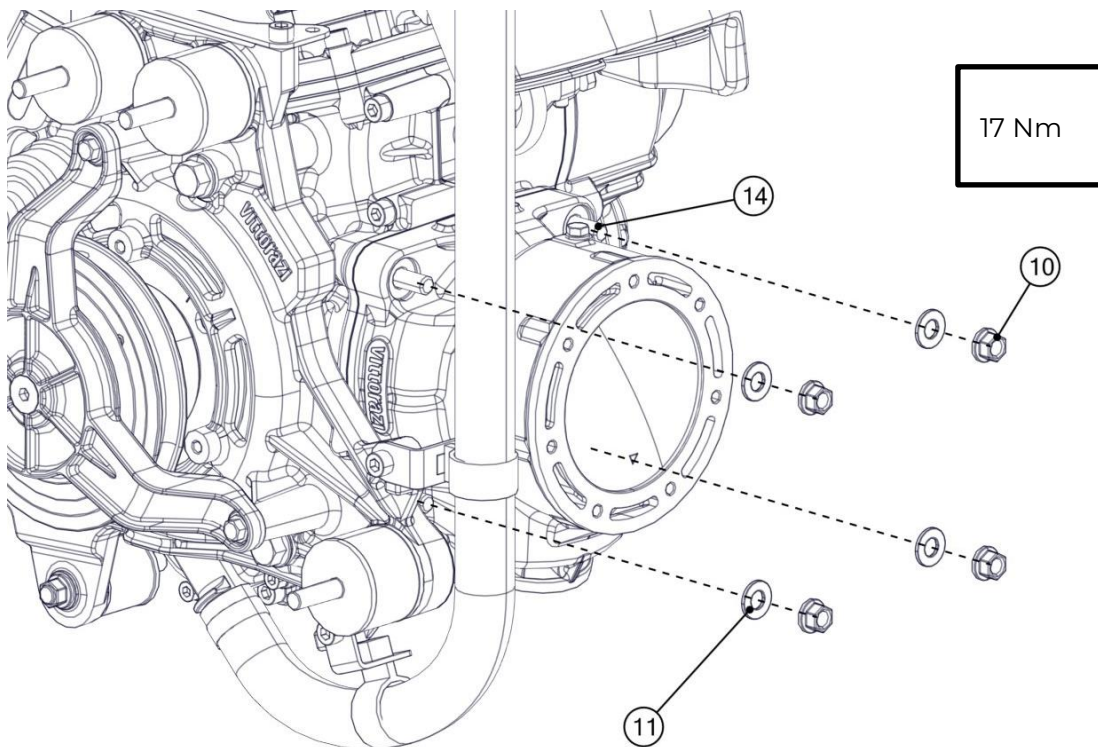

Pull the handle of the manual starter and check the movement of the piston.
Screw the pin (20) [ACC116] into the central hole (21) at the top of the cylinder.

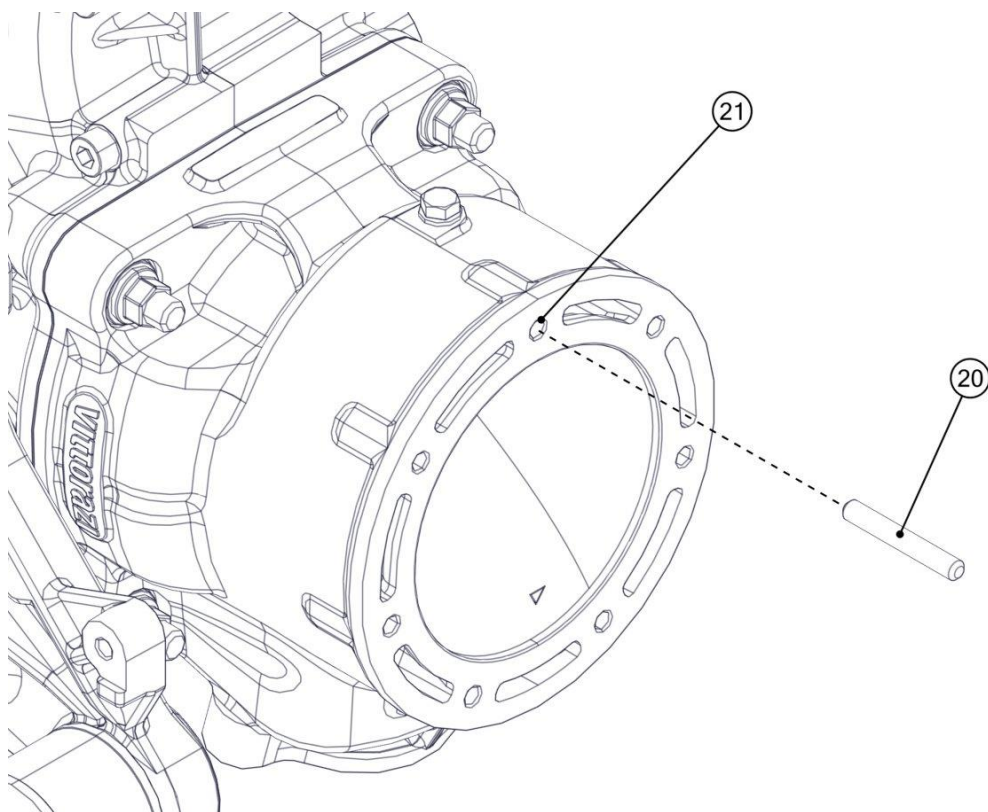

Replace the gasket (9) [C016] each time it is disassembled.
Position the gasket (9) [C016] as in the photo on the left: the white mark (highlighted in the photo) is on the side of the head.



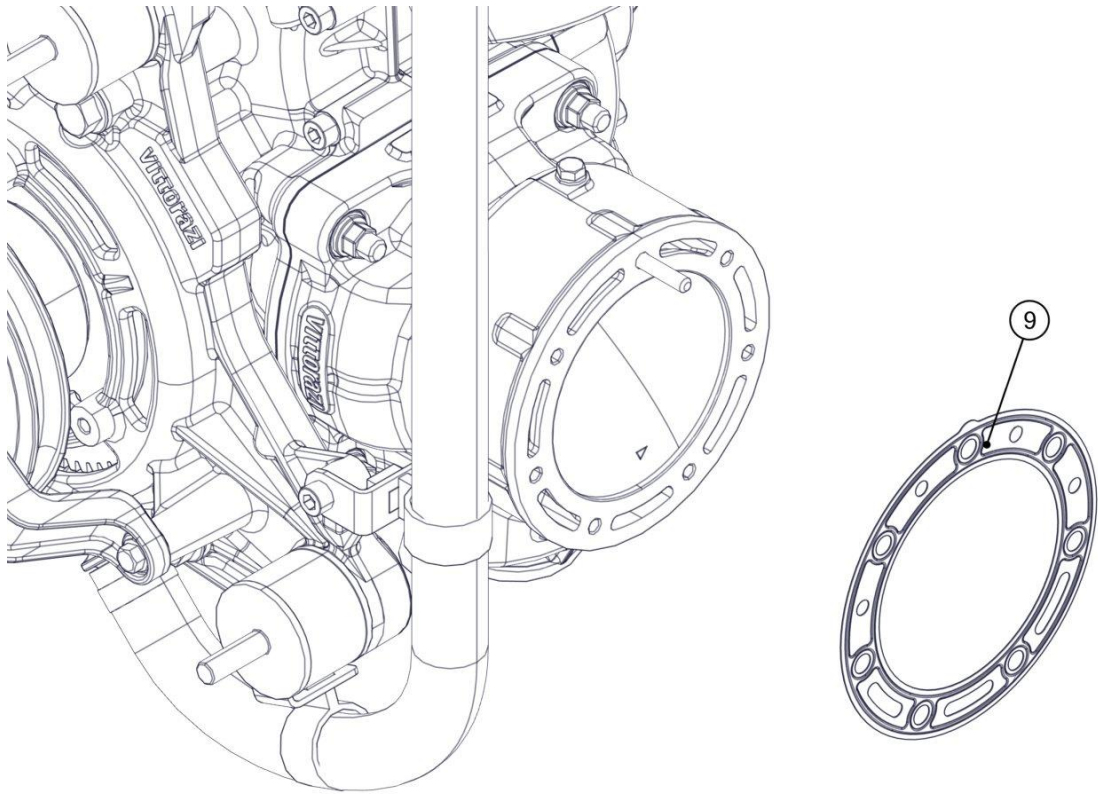

Move the head (8) closer to the cylinder, paying attention to the position of the gasket (9).

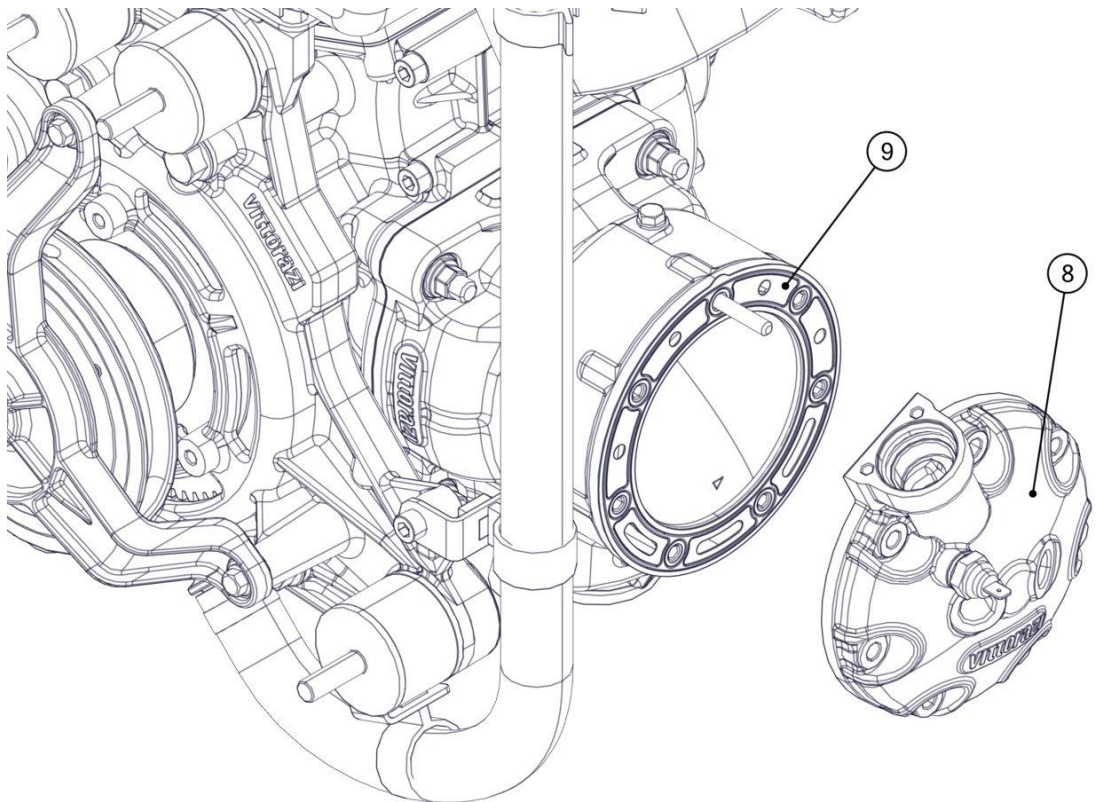

Insert the 6 Allen screws M6x30 (6) with washers (7) on the head (8) and pre-tighten.

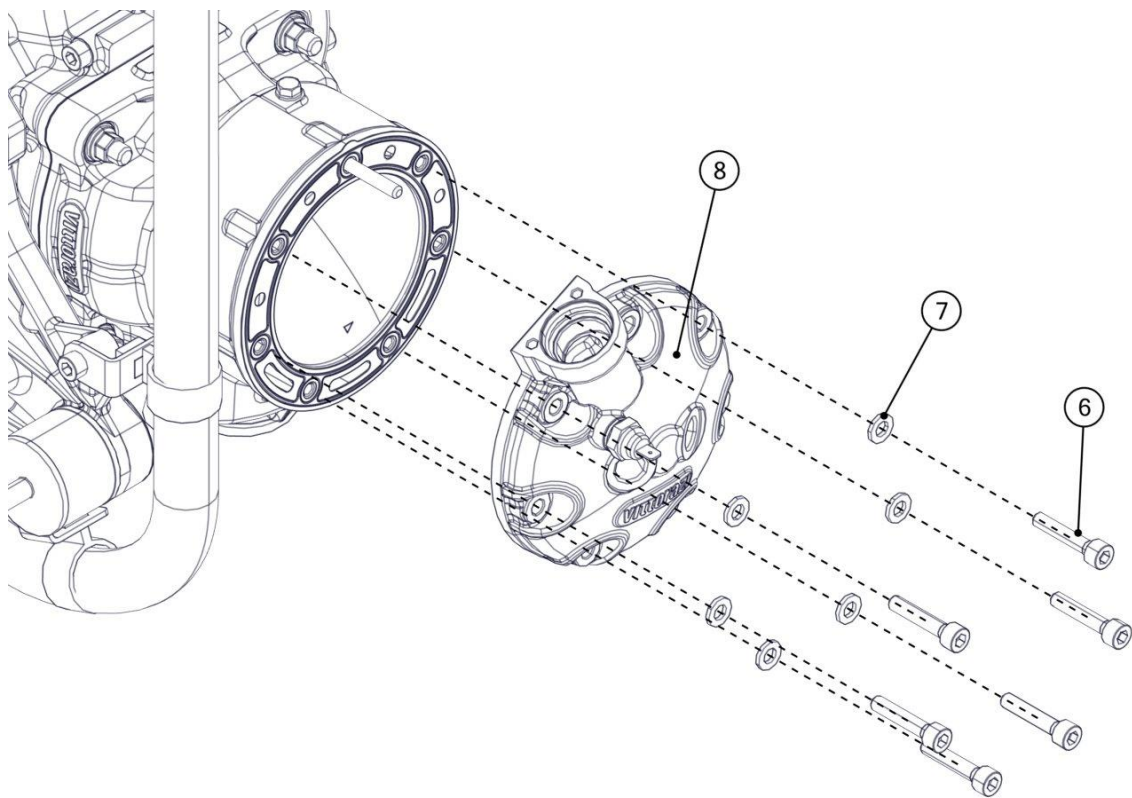

Remove the pin (20).

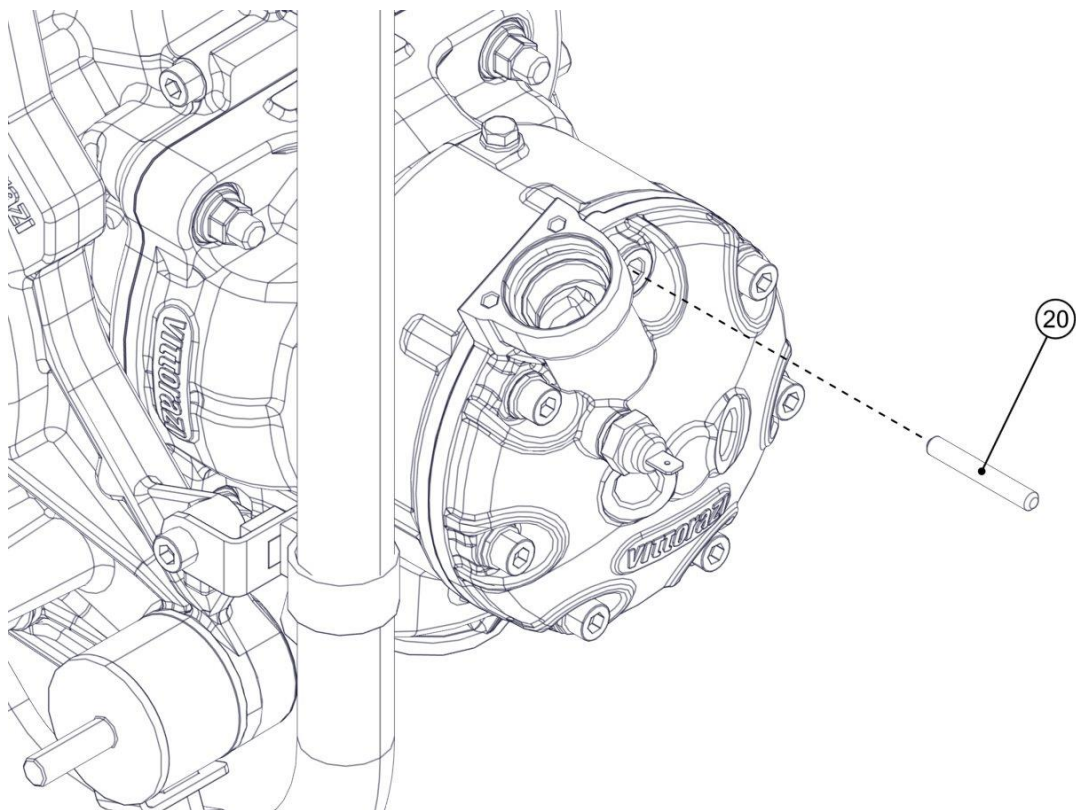

Insert the remaining Allen screw M6x30 (6) with washer (7) on the head.
Tighten the 7 Allen screws M6x30 alternately and cross-tighten with the torque shown in the figure.
Check that all 7 Allen screws M6x30 are tightened correctly.

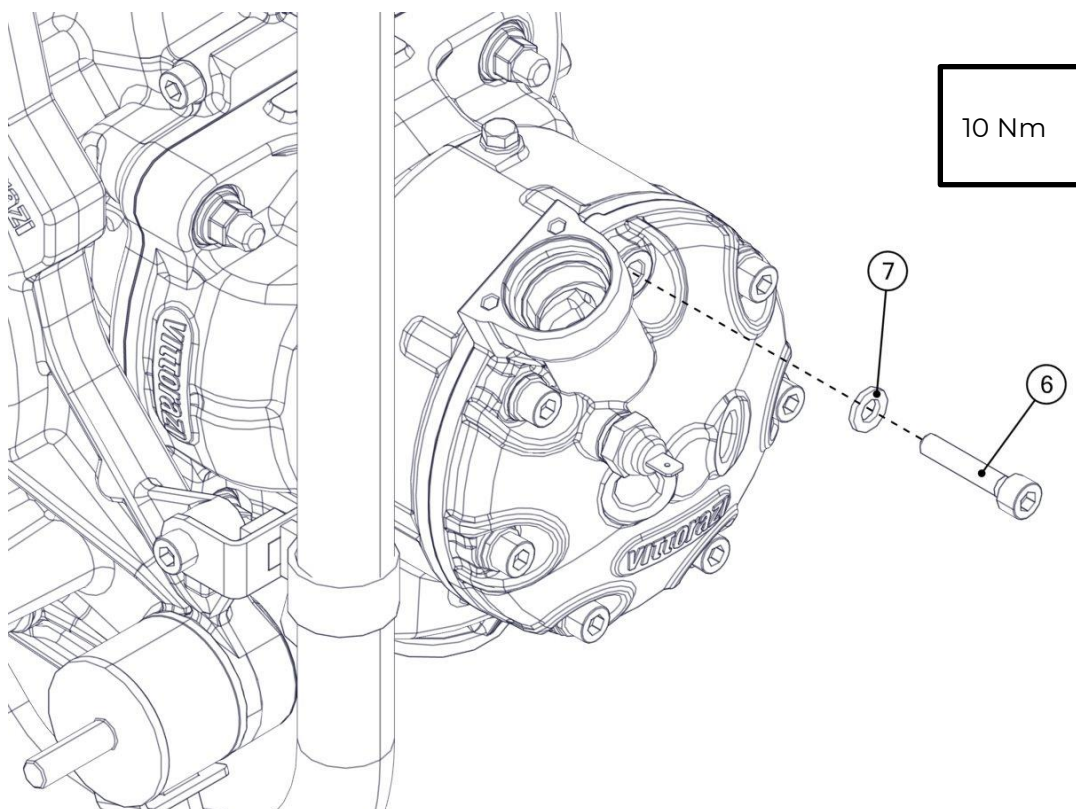

Grease the O-ring (4) with FP Silicompond 225 and place it on the connector (3).
Insert the thermostat (5), the connector (3), the 2 Allen screws M5x10 (1) with washers (2) and
tighten with the torque shown in the figure.

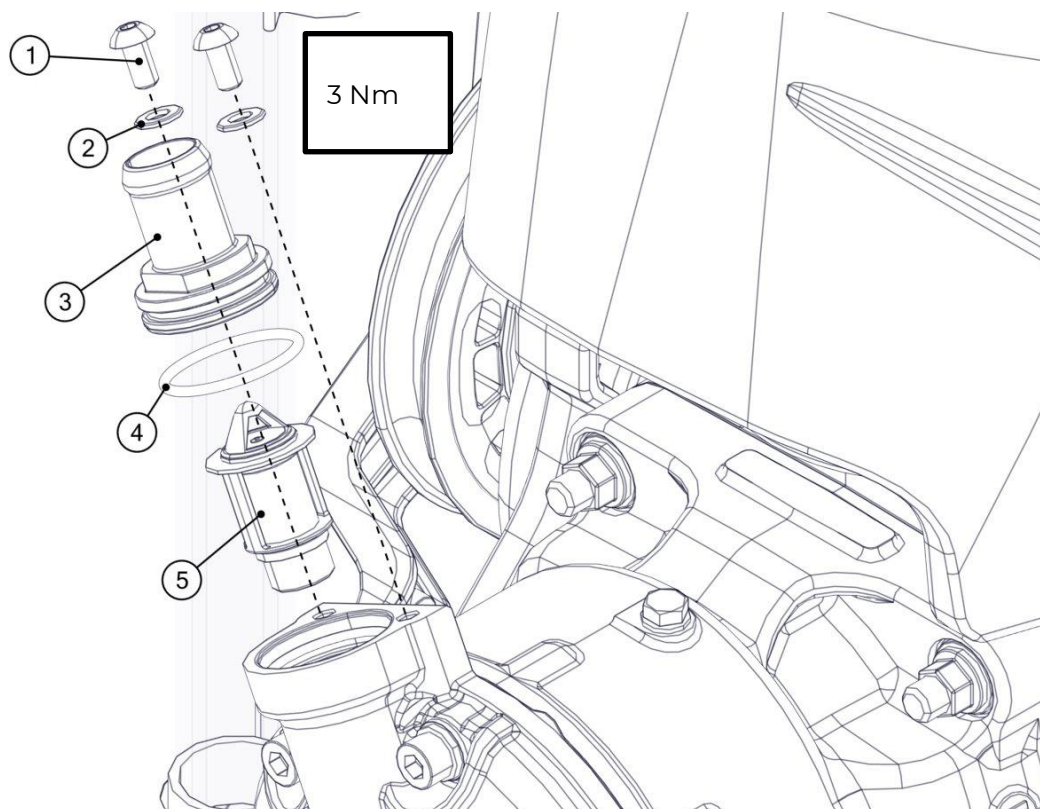



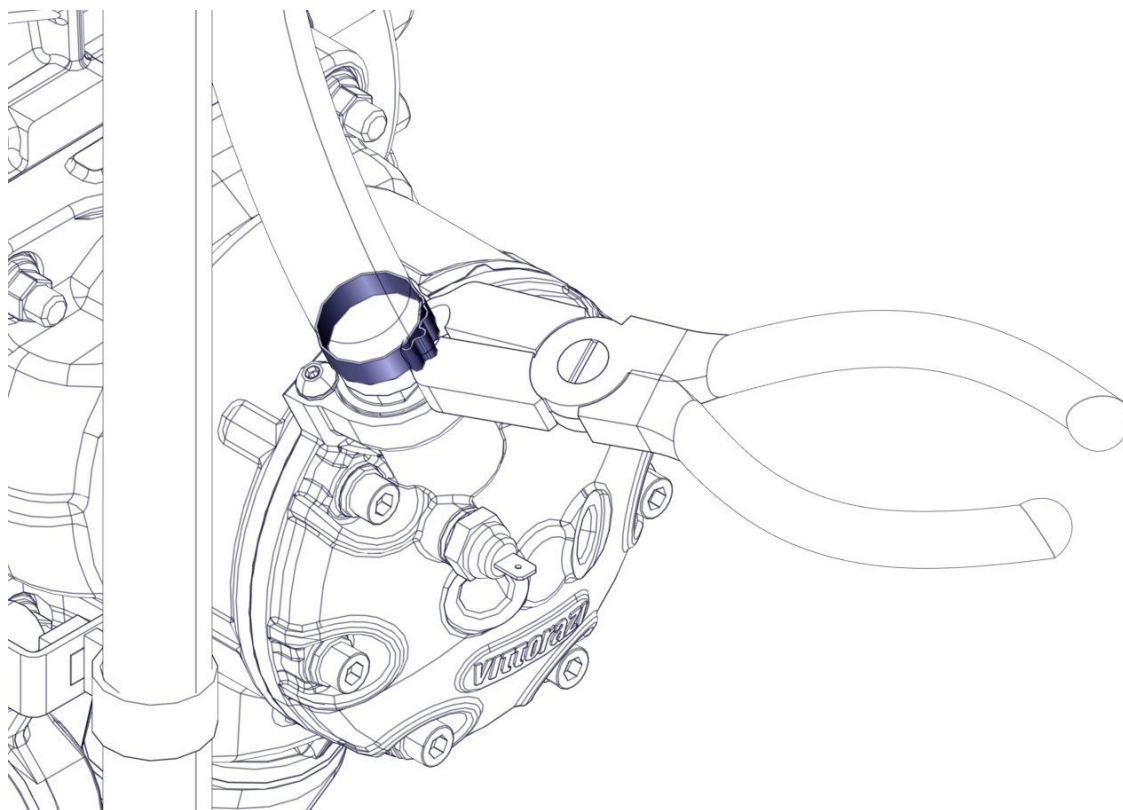

Replace the clamp each time it is disassembled.

Connect the radiator hose to the head and tighten the clamp with a specific pliers.



Check the squish measurement on 2 sides of the piston on the pin axis: acceptable values range **from 1,25 mm to 1,45 mm.**

3.15 Crankcase

 Components to replace		Time limit
	Bearings (C005)	200 h
	Crankshaft (C001) includes: nut M12x1,25 (C037), Seeger ring (C005c)	on condition
	Oil seals* (C006, C001e)	200 h
	Gasket* (C412)	200 h
	Screws M5x12* (C005b)	200 h
	Bearing retainer* (C005a)	200 h
	Countershaft (C001b)	on condition
	Crankcase (C002) includes: bearing retainer (C005a), screws M6x50 (M119), brass junction (M024)	on condition
	Three Bond 1215 silicone paste* (ACC131)	200 h
FP Silicompound 225*	200 h	
 Special tools	Countershaft locking tool (ACC117). Extractor (ACC113). Specific tool (ACC118). Specific tool (ACC119). Specific tool (ACC120). Specific tool (ACC121).	
 Values	Screws M6x50: 10 Nm. Screws M5x12: 8 Nm. Screws M6x25: 10 Nm. Impeller nut M5: 8 Nm	

*Always replace it when disassembled.

3.15.1 Crankcase disassembly



Before disassembling the engine crankcase, remove the airbox (3.3 Airbox), the carburettor (3.4 Carburettor), the reed valve (3.5 Reed valve), the exhaust system (3.7 Exhaust system), the coolant (3.8 Cooling system), the rubber mountings (3.9 Rubber mountings), the pull starter system (3.10 Pull starter system), the electric starter (3.11 Electric starter), the flywheel (3.12 Flywheel), the transmission (3.13 Transmission) and the cylinder unit (3.14 Piston, cylinder, head).

Remove the oil seal (1) and the Seeger ring (2) from the crankshaft (3).

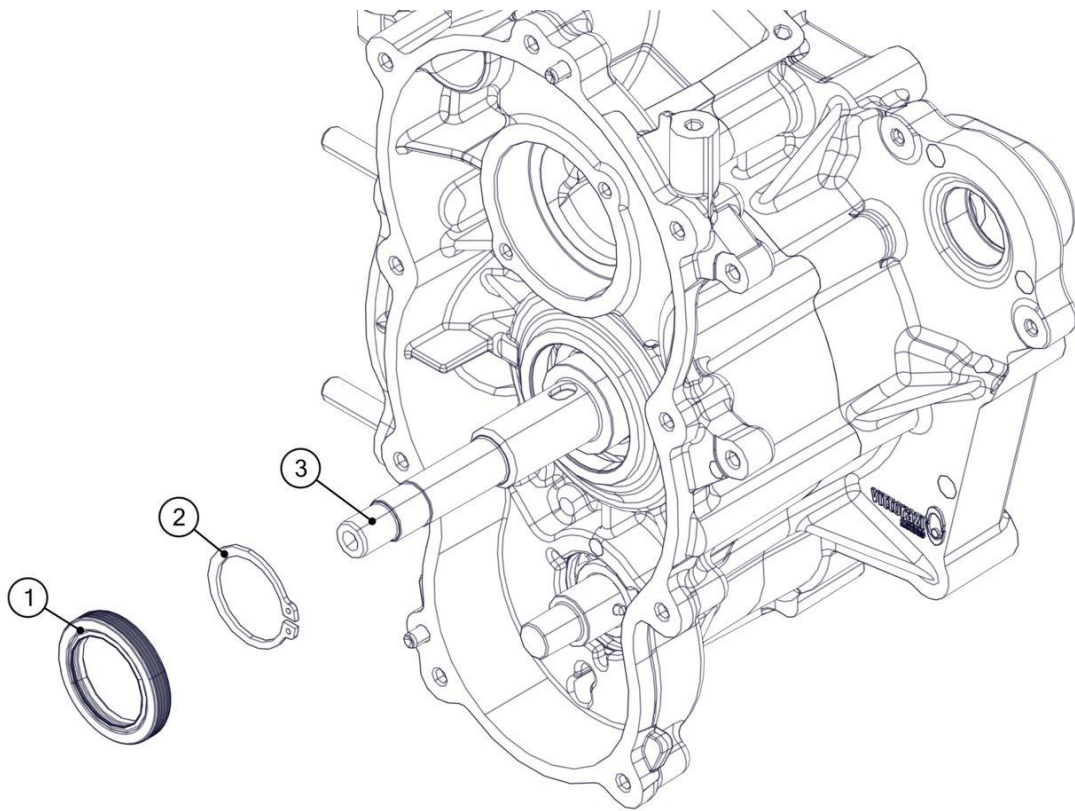

Remove the 5 Allen screws M5x20 (4) from the water pump cover (5).
Remove the cover (5) and the gasket (6).

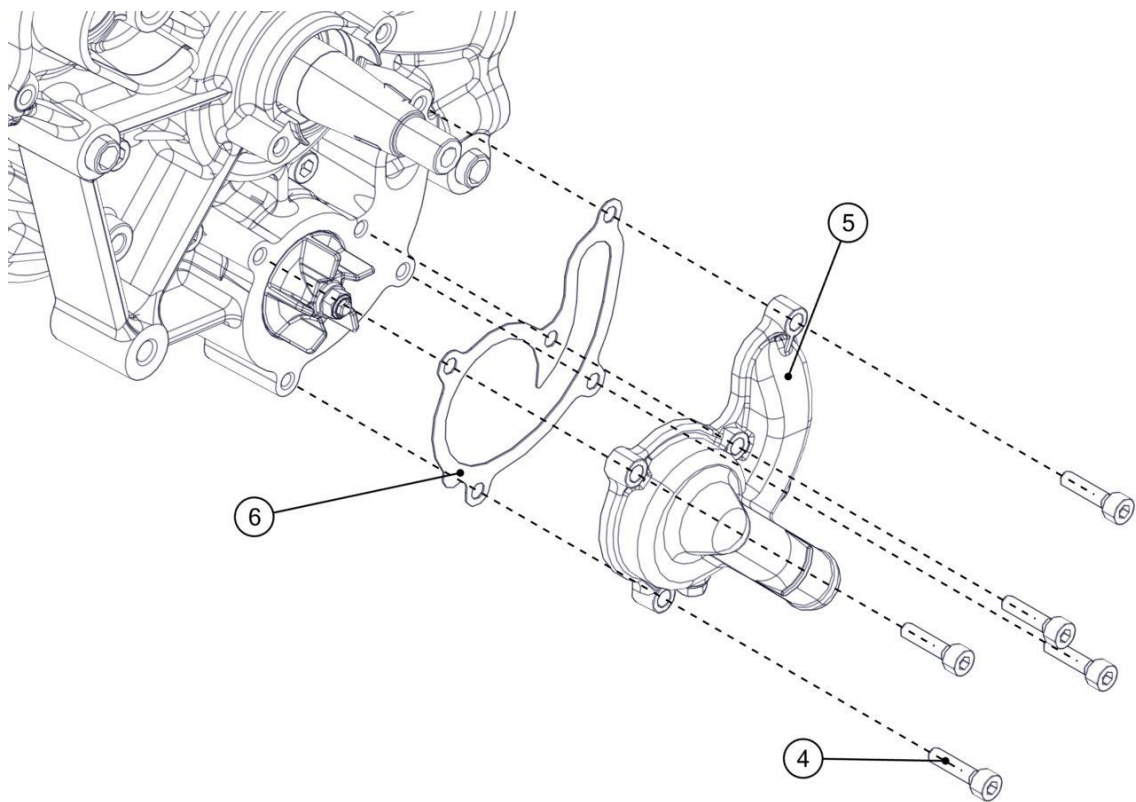

Insert the countershaft locking tool (7) [ACC117] and hold it in position.

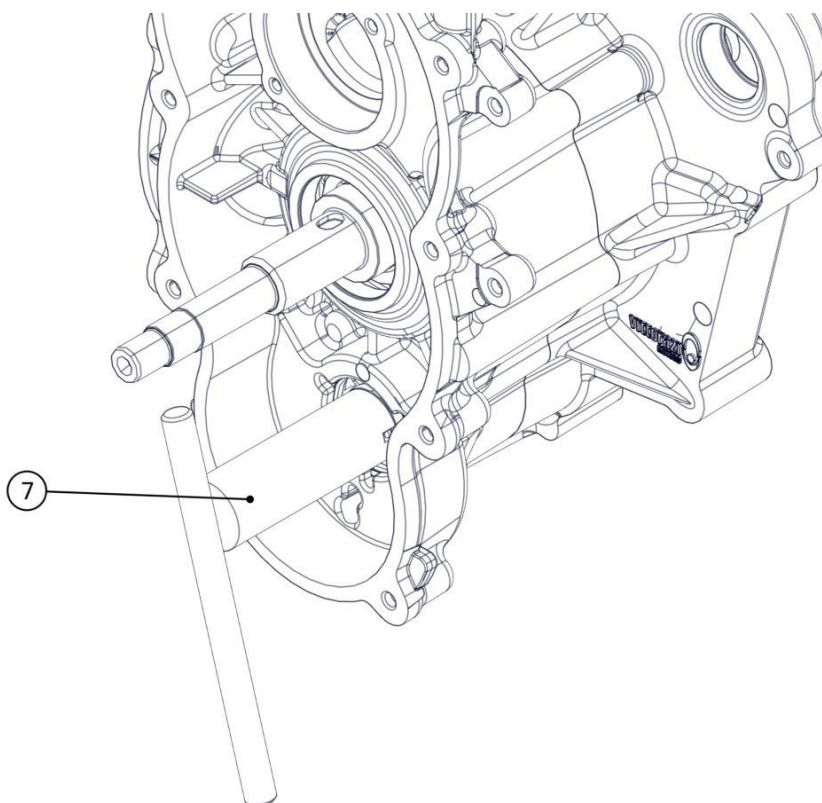

Remove the nut (8) and unscrew the pump impeller (9) from the countershaft.

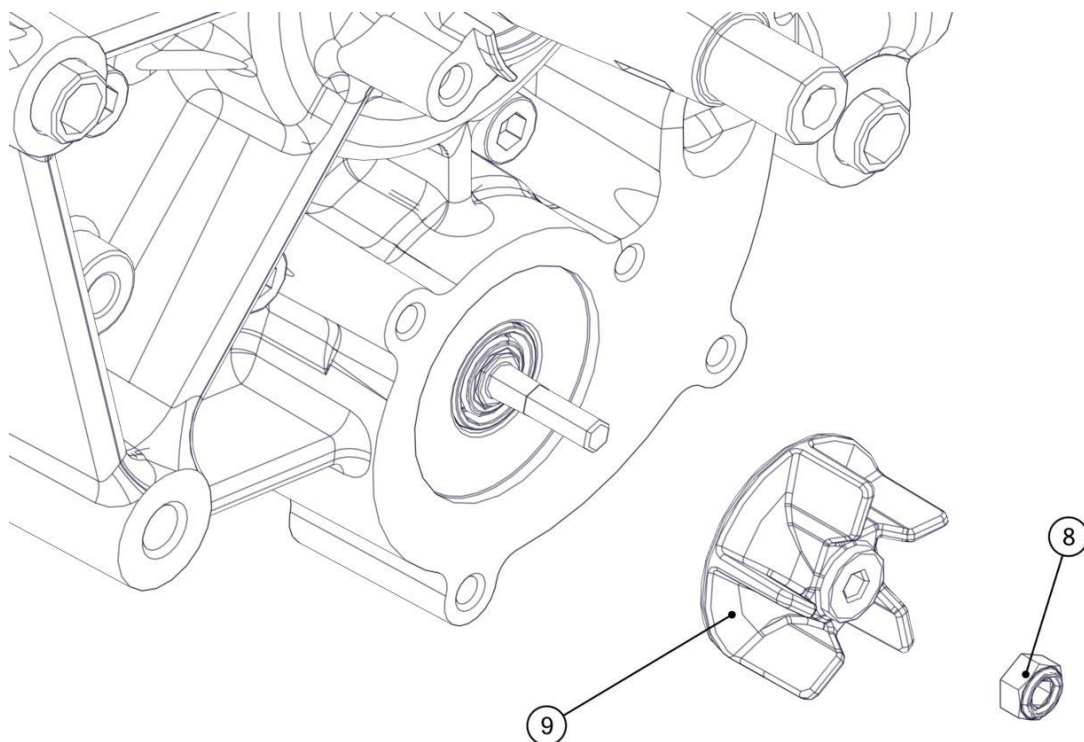

Remove the 10 Allen screws M6x50 (10) from the crankcase (11).

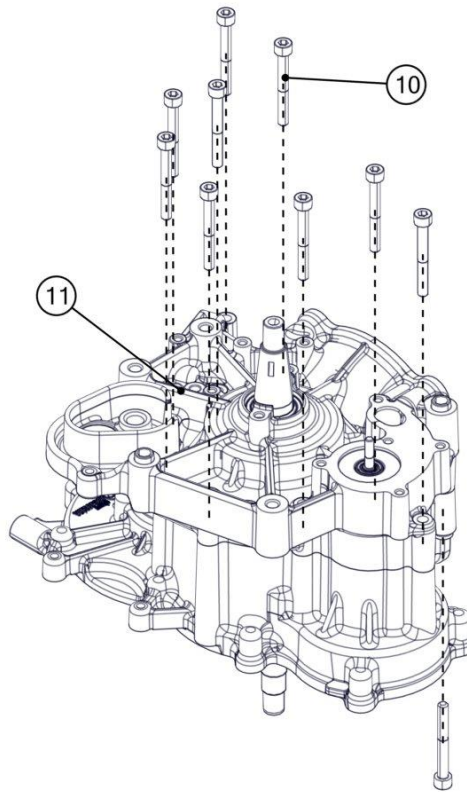

Position the extractor (12) [ACC113] on the crankshaft (3), tighten the 2 screws M6 (13) and turn the central pin (14) until the 2 case-half are separated.

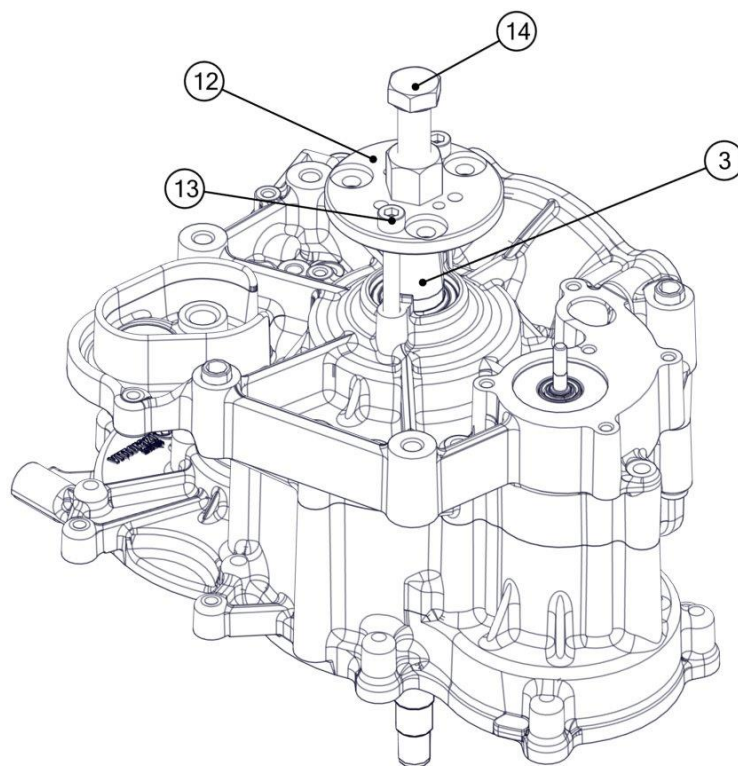

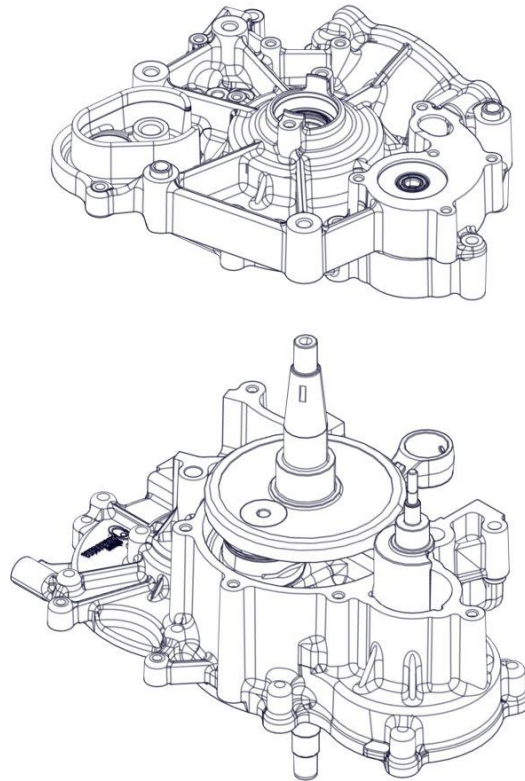

Heat the manual starter side crankcase to 120 °C.
Remove the crankshaft bearing (15), the countershaft bearing (16), the crankshaft oil seal (17).
Remove the countershaft oil seal (18) using the specific tool (19) [ACC120].

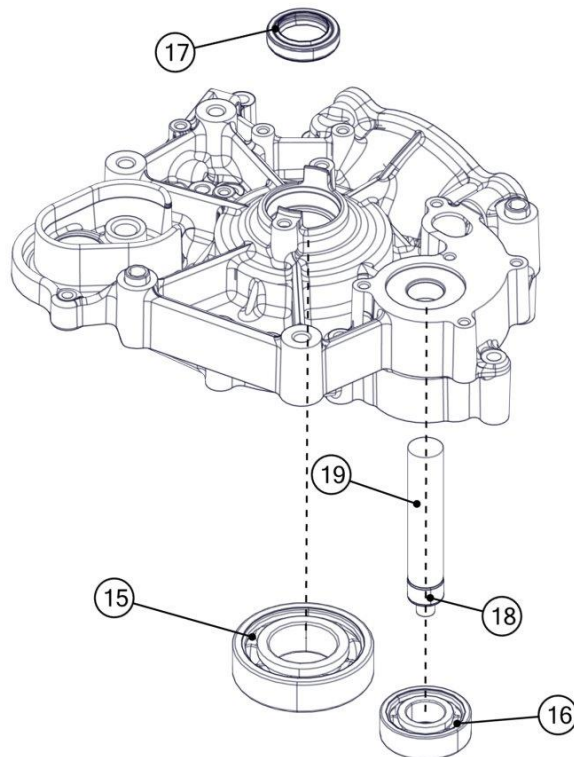

Heat the transmission side crankcase to 120 °C.
Remove the countershaft (20).

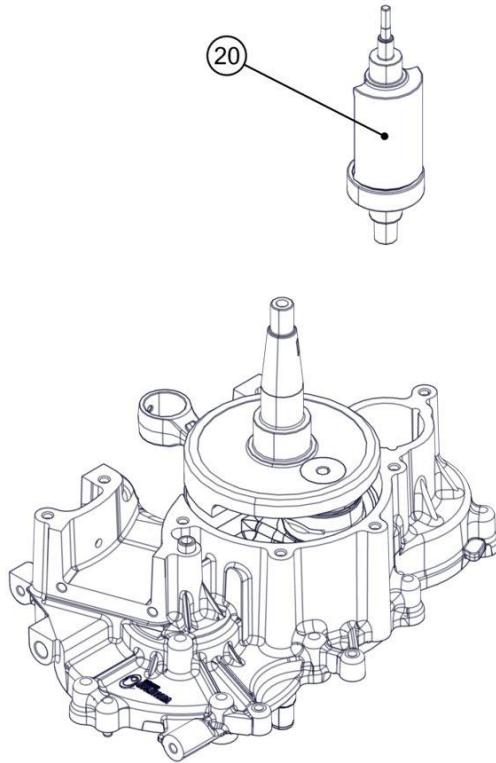

Heat the countershaft (20) near the pin at 120°C and remove the pin (21).
Heat the bearing (22) and remove it.

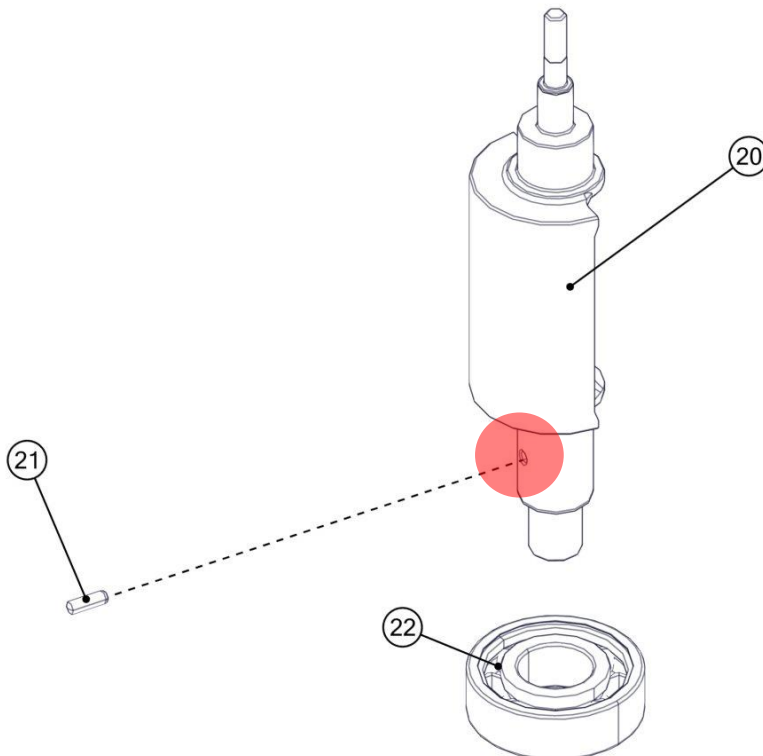

Remove the crankshaft (3) using a press in the direction shown in the figure.

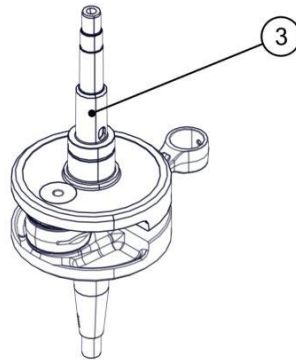
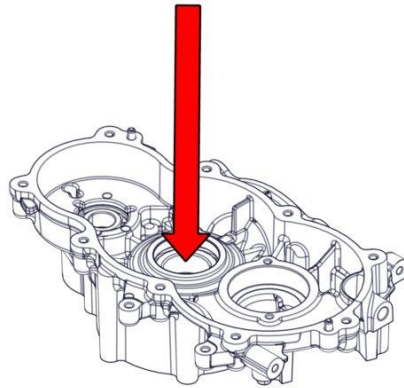

Remove the 3 screws M5x12 (23) and the bearing retainer (24).
Heat the transmission side crankcase to 120 °C.
Remove crankshaft bearing (25) on the transmission side.

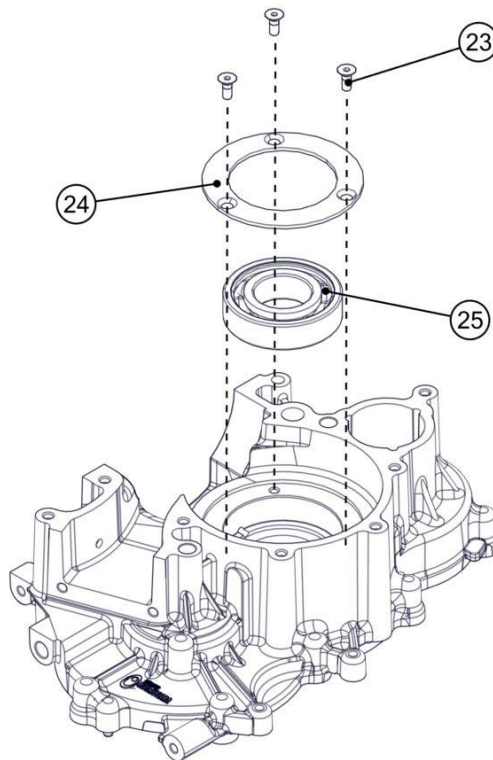

3.15.2 Crankcase maintenance

Degrease the bearing seats and the profile of the case-half with specific products for aluminium. Check the case-half: check for integrity and abnormal marks.

Check the 4 bearing seats: there must be no polished areas. Also measure the diameter of the 4 seats, the table shows the factory settings.

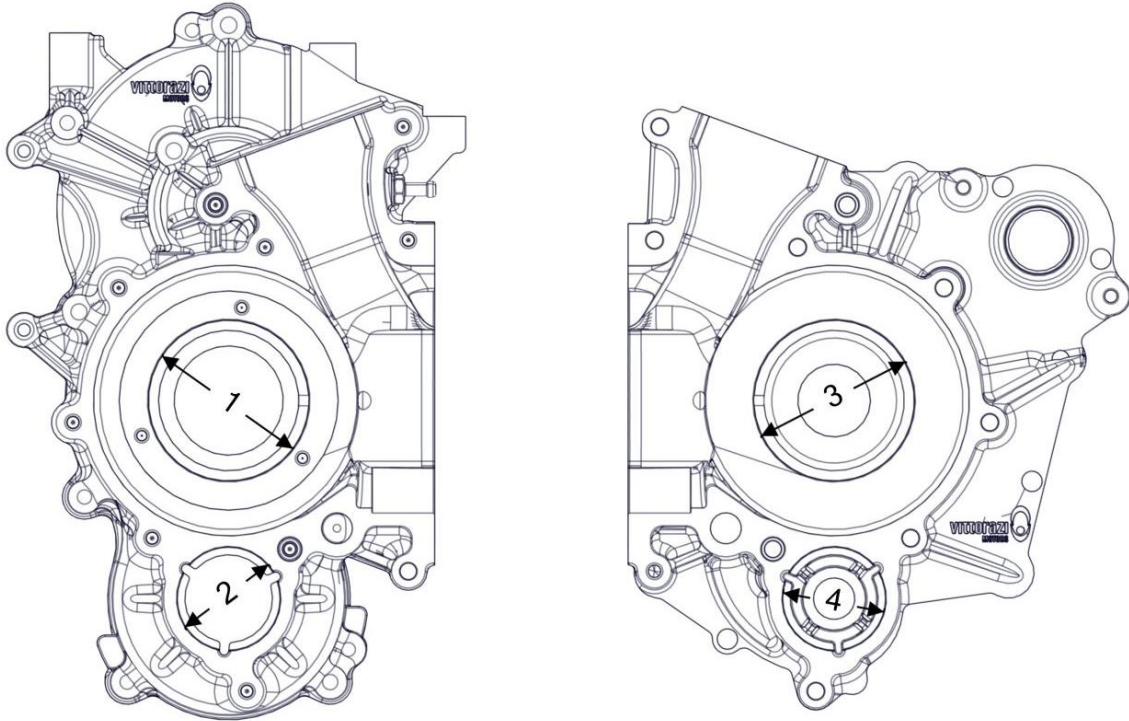

Dimension	Factory settings at 20° C (mm)
1	61,955-61,970
2	39,980-39,996
3	61,955-61,970
4	39,980-39,996

Measure the diameter of the 3 bearing seats on the crankshaft, the table shows the factory settings.

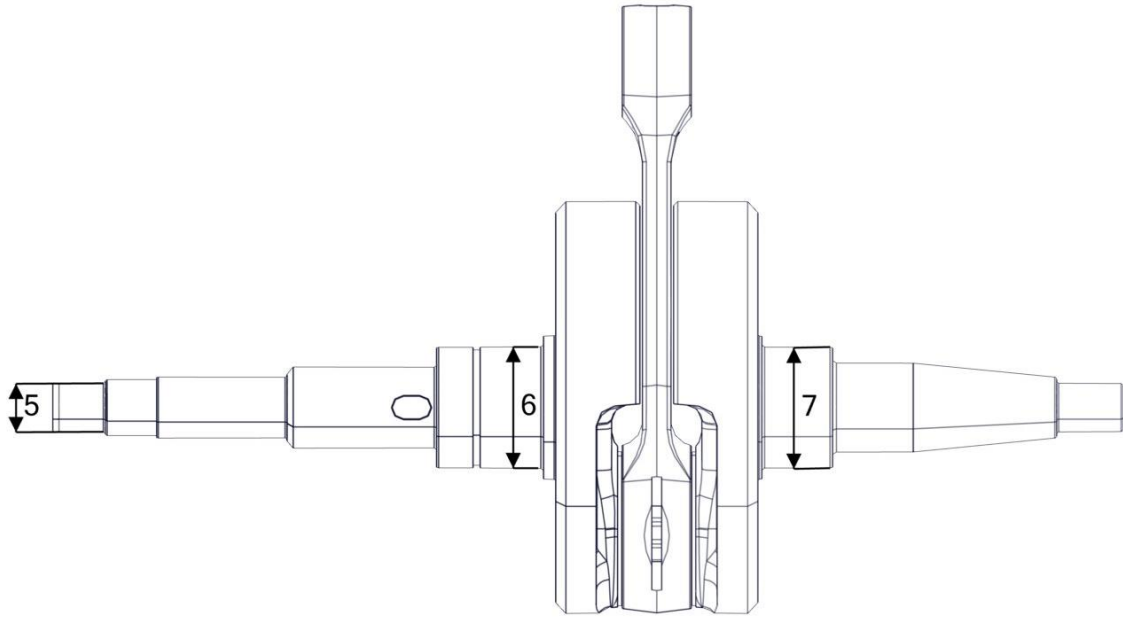

Dimension	Factory settings at 20° C (mm)
5	11,973-11,984
6	30,001-30,007
7	30,001-30,007

Measure the clearance at the small end and big end of the connecting rod.

	Factory nominal clearance* (mm)
Small end	0,011±0,005
Big end	0,03±0,005

* at 20 °C

Check on the connecting rod that there are no areas of different color due to overheating.

Measure the eccentricity of the crankshaft, the factory settings are shown in the figure.

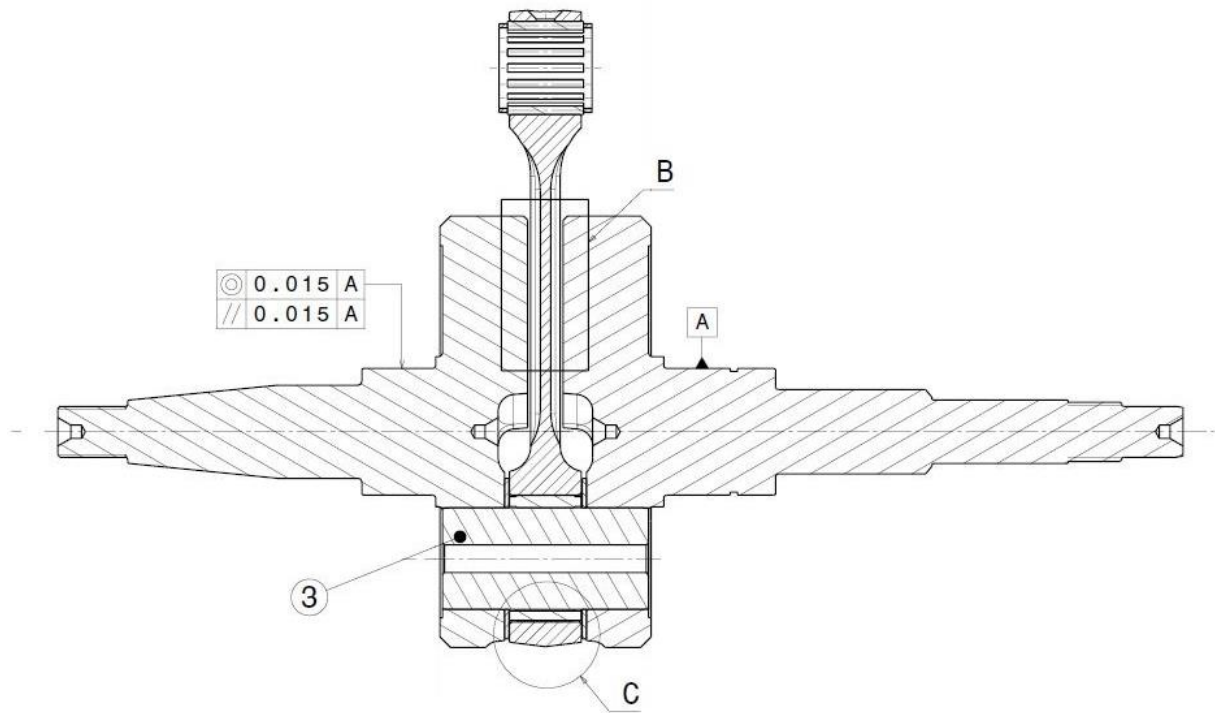

Check that the seat of the key is undamaged.

If the above checks are not passed, replace the crankshaft.

Measure the diameter of the 2 bearing seats on the crankshaft, the table shows the factory settings.



Dimension	Factory settings at 20° C (mm)
8	16,983-16,994
9	16,983-16,994

3.15.3 Crankcase assembly

Heat the inner rings of the 2 bearings of the countershaft (16, 22) to 120 °C.
Fit the 2 bearings (16, 22) on the countershaft (20).

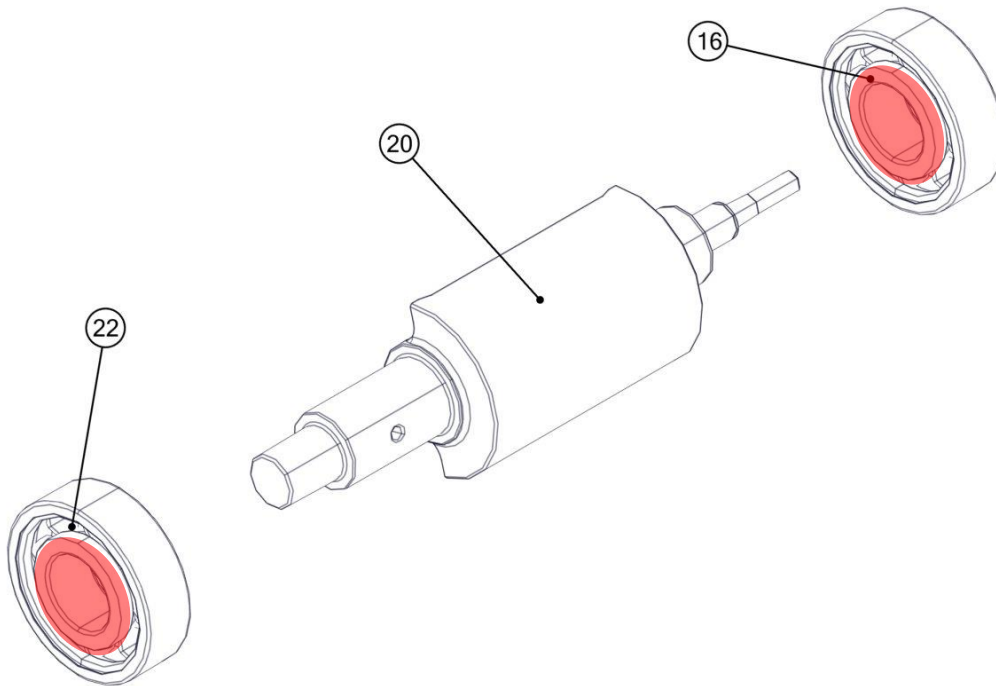

Insert the pin (21) with threadlocker (Loxéal 55-03/Loctite 243 recommended) on the countershaft (20).

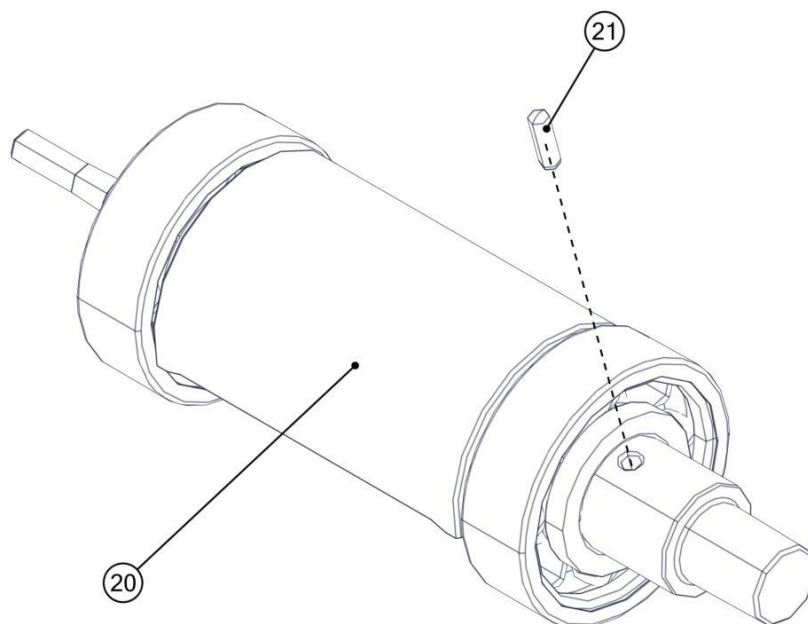

Heat the inner ring of the bearing (15) to 120 °C and fit it on the crankshaft (3).

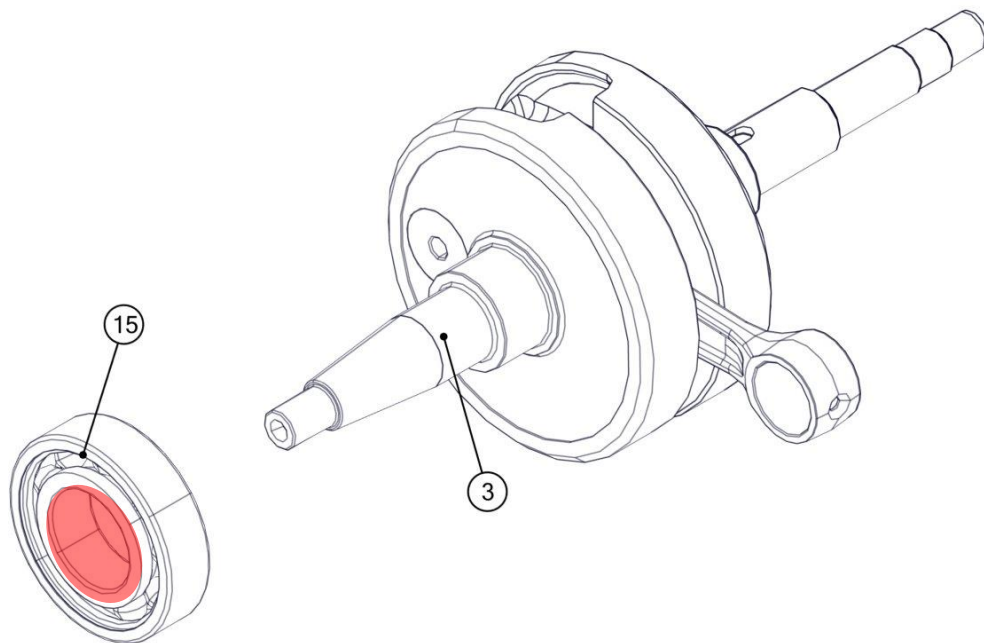

Heat the transmission side crankcase to 120 °C.
Insert the countershaft (20) with the 2 bearings.

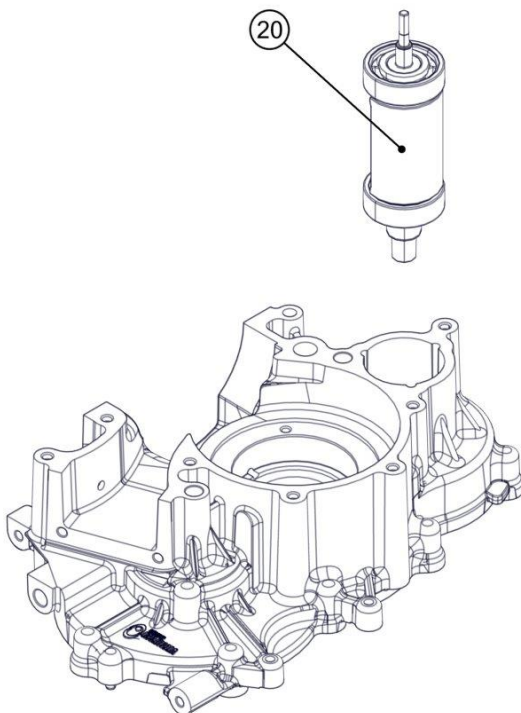



Replace the screws M5x12 (23) and the bearing retainer (24) each time they are disassembled.

Insert the crankshaft bearing (25) with the bearing retainer (24) and the 3 screws M5x12 (23) and tighten with the torque shown in the figure.

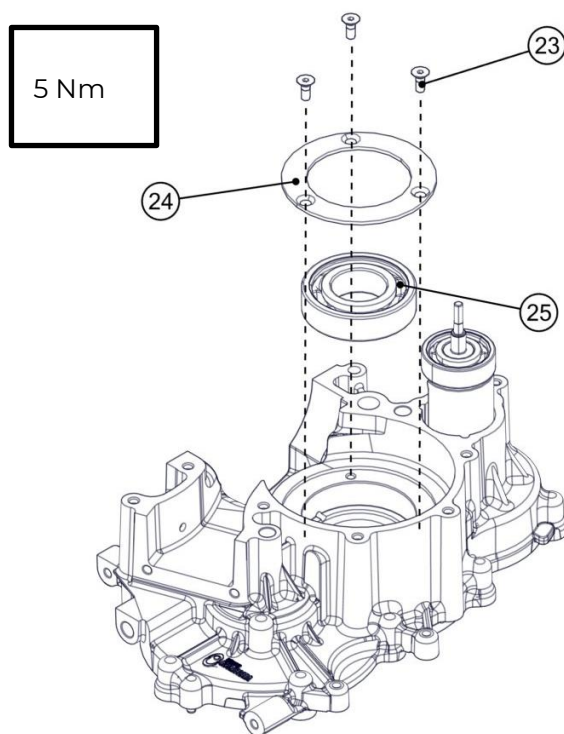

Heat the inner ring of the bearing (25) to 120 °C.
Insert the crankshaft (3) with the bearing.

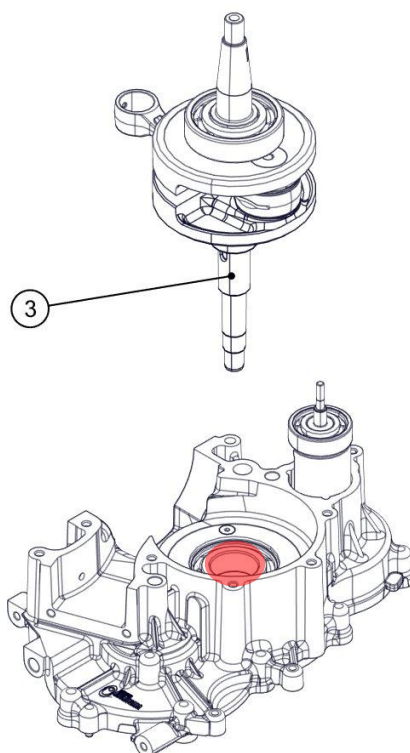

Heat the manual starter side crankcase to 120 °C.



Carry out subsequent operations within a maximum of 5 minutes (application of silicone and closing of the crankcase).

Carefully add silicone paste (Three Bond 1215) to the crankcase profile as shown in the figure. Height, width silicone profile: 2 mm x 2,5 mm.

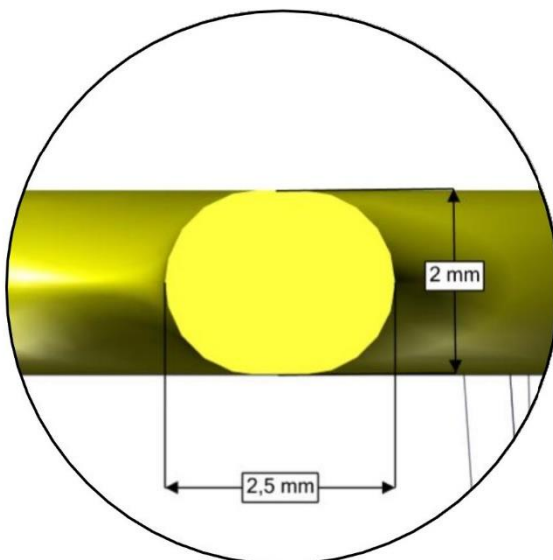
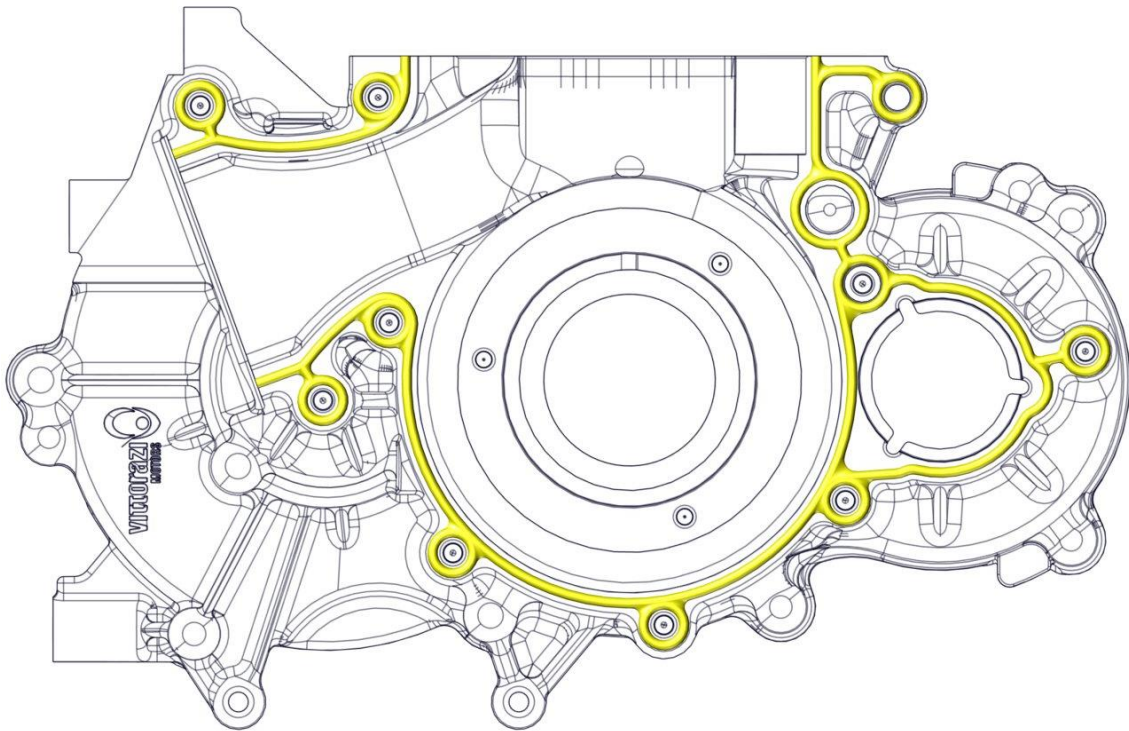



Check that the 2 bushings are in their respective seats (highlighted in the figure).

Close with the manual starter side crankcase still warm at 120 °C.

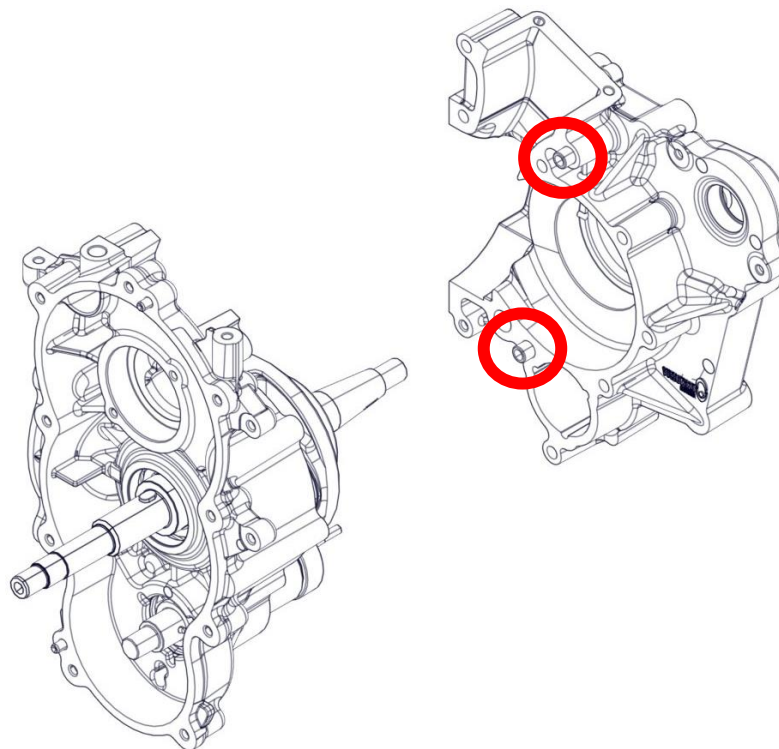

Insert the 10 Allen screws M6x50 (10) on the crankcase (11) and tighten with the torque shown in the figure.

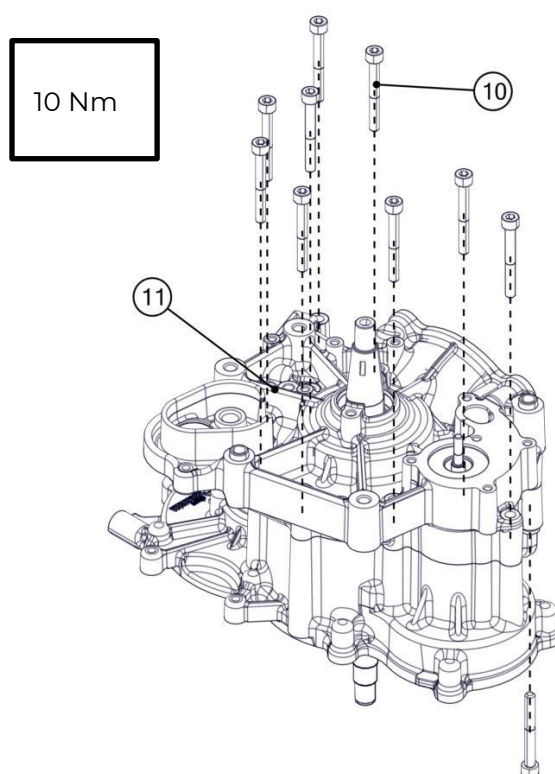

Clean the excess silicone from the crankcase perimeter with a cloth.
Wait for the crankcase to cool down.



Replace the 2 oil seals (10, 20) each time they are disassembled.

Grease the oil seal (17) with FP Silicompond 225 and place it on the crankshaft (2) using the specific tool (17) [ACC118] to insert it.

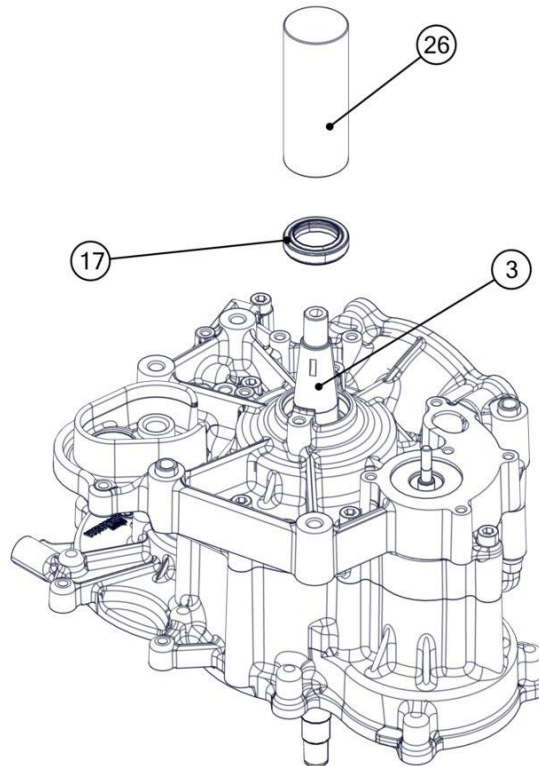

Insert the part A of the specific tool [ACC119] on the countershaft.

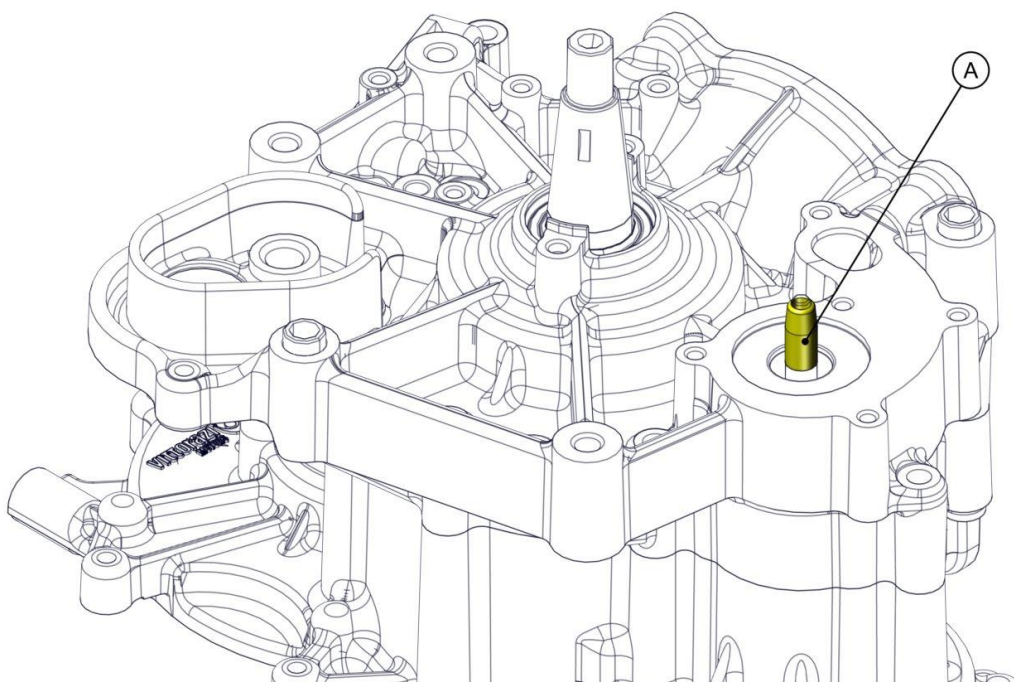

Abundantly grease the oil seal (18) with FP Silicompond 225 and place it on the part B.

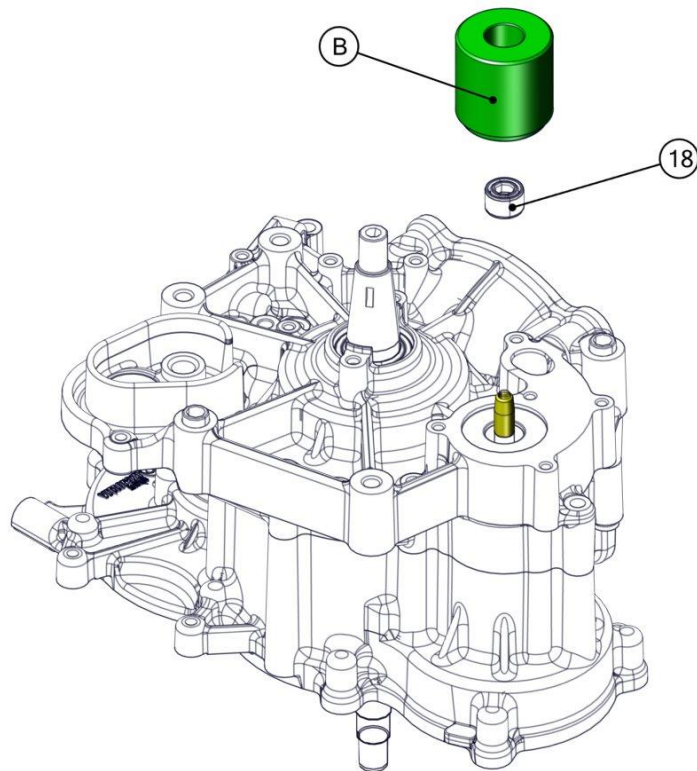

Insert the part B with the oil seal on the countershaft.
Fully insert the part C on the part B.

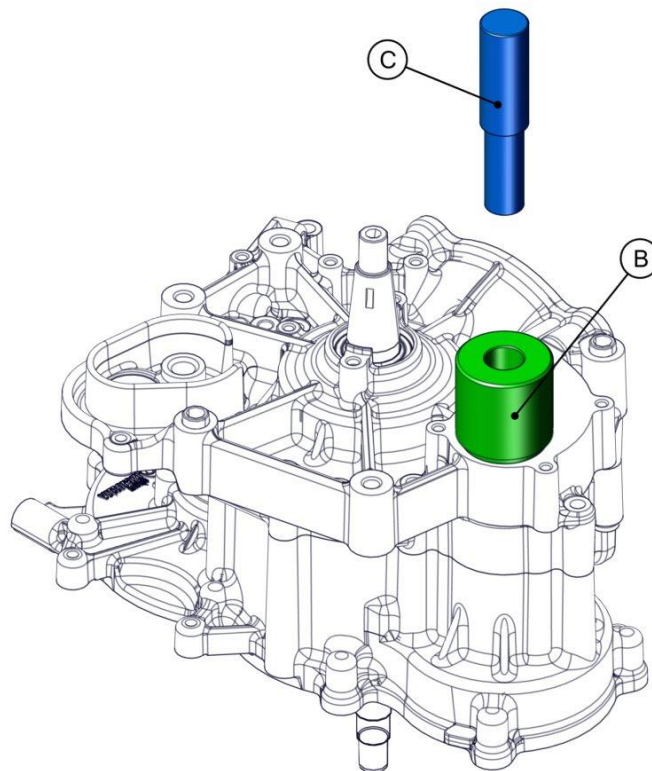

Remove the part C, B and A.

Insert the countershaft locking tool (7) [ACC117] and hold it in position.

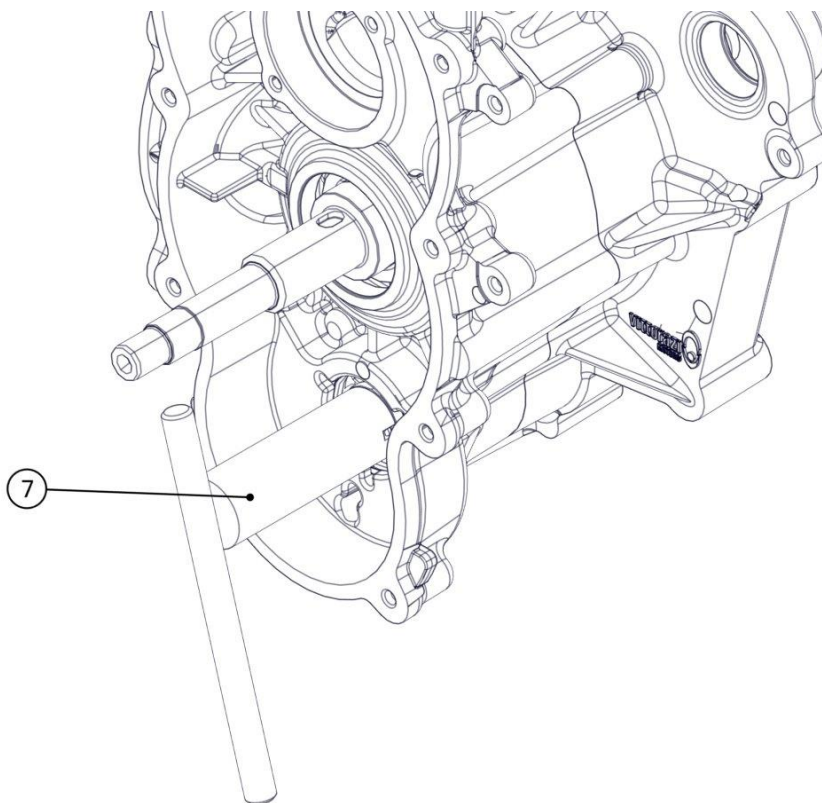

Screw the pump impeller (9) onto the countershaft.
Insert the nut (8) and tighten with the torque shown in the figure.

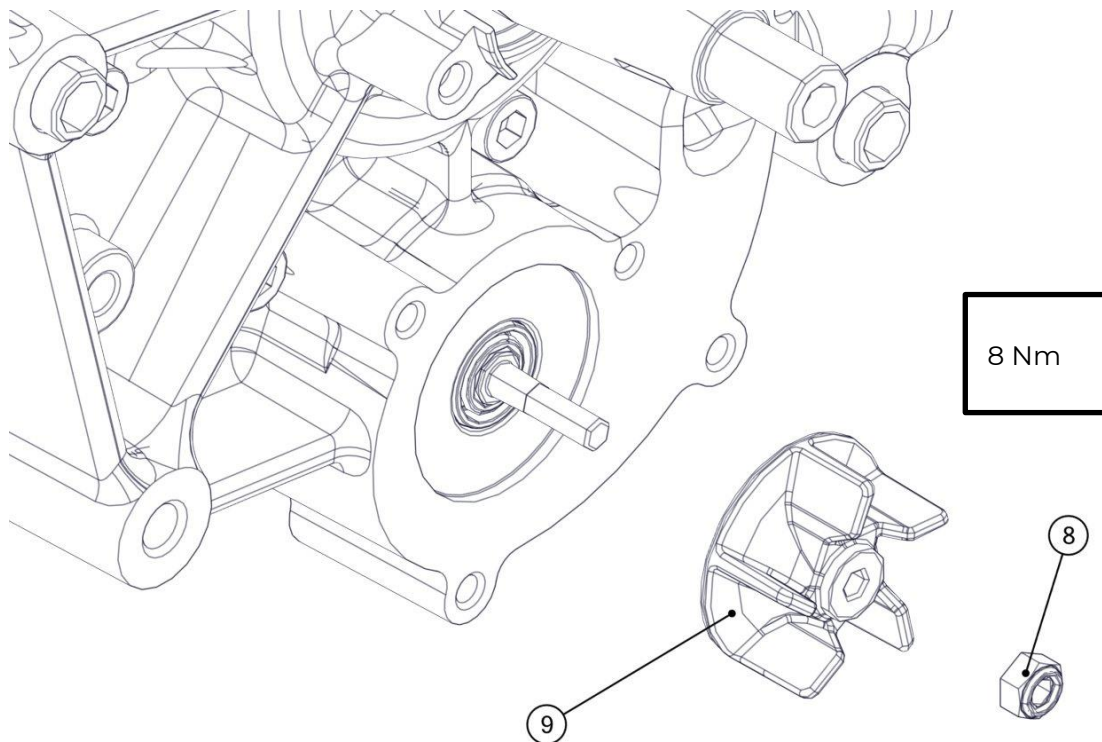



Replace the gasket (6) each time it is disassembled.

Insert the gasket (6).



Insert the water pump cover (5), paying attention to the position of the gasket.

Insert the 5 Allen screws M5x20 (4) into the cover (5) and cross-tighten with the torque shown in the figure.

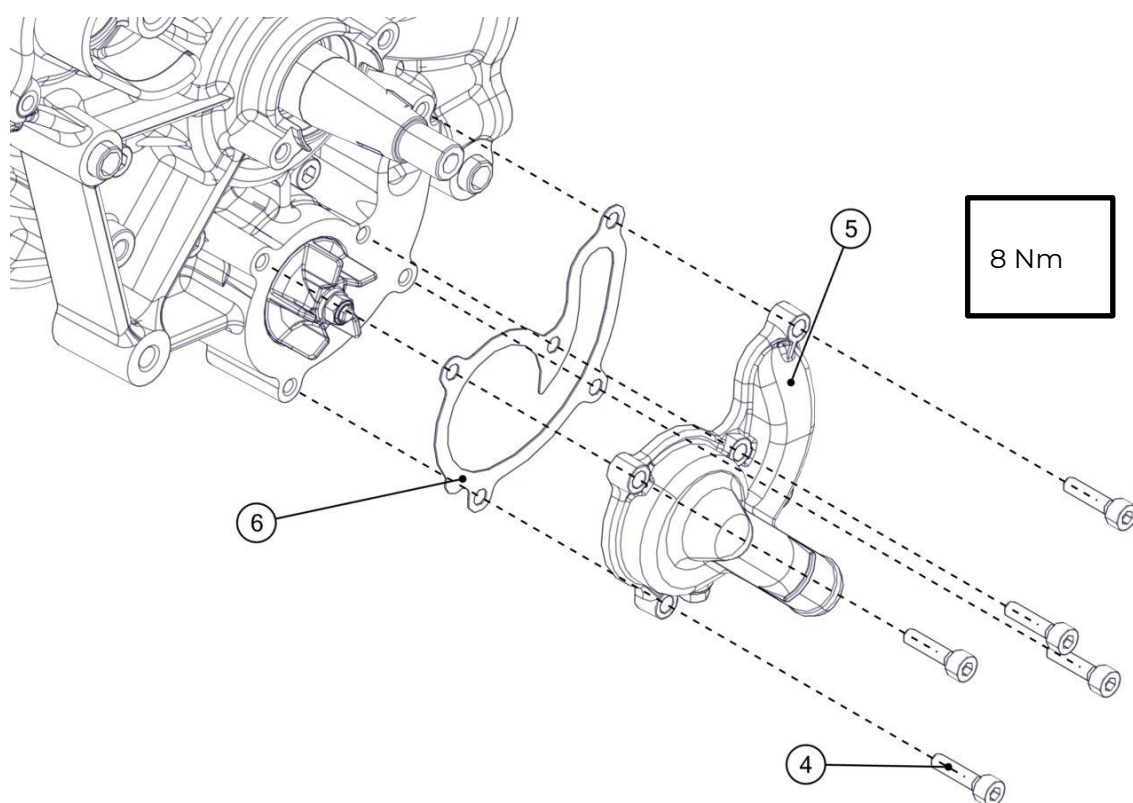

Insert the Seeger ring (2) on the crankshaft (3).

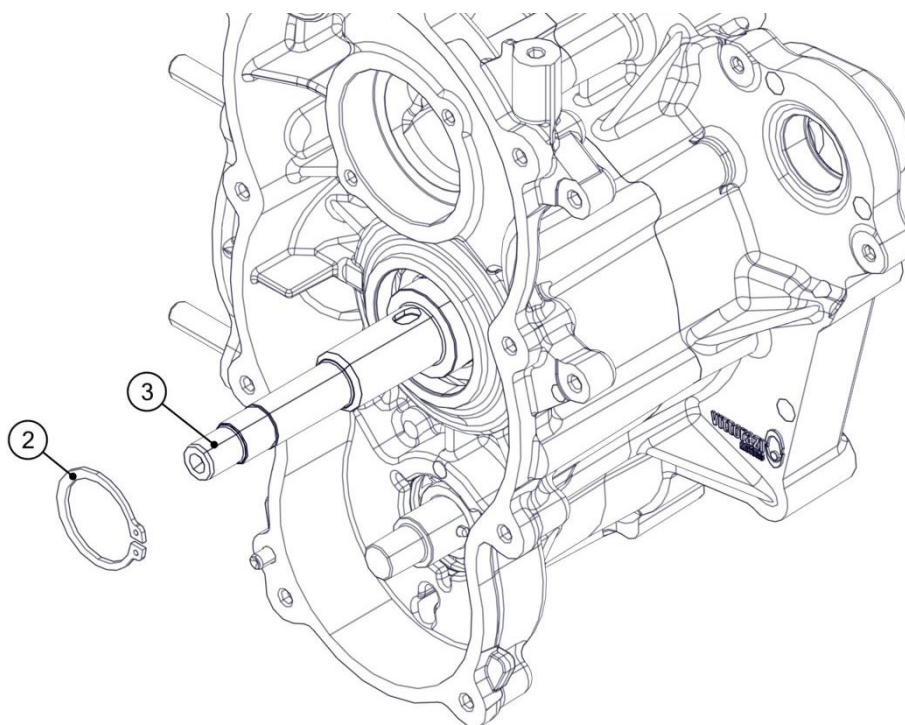

Replace the oil seal (1) each time it is disassembled.

Insert the part A of the specific tool [ACC121] on the crankshaft.
Grease the oil seal (1) with FP Silicompond 225 and place it on the crankshaft using the part B to insert it.

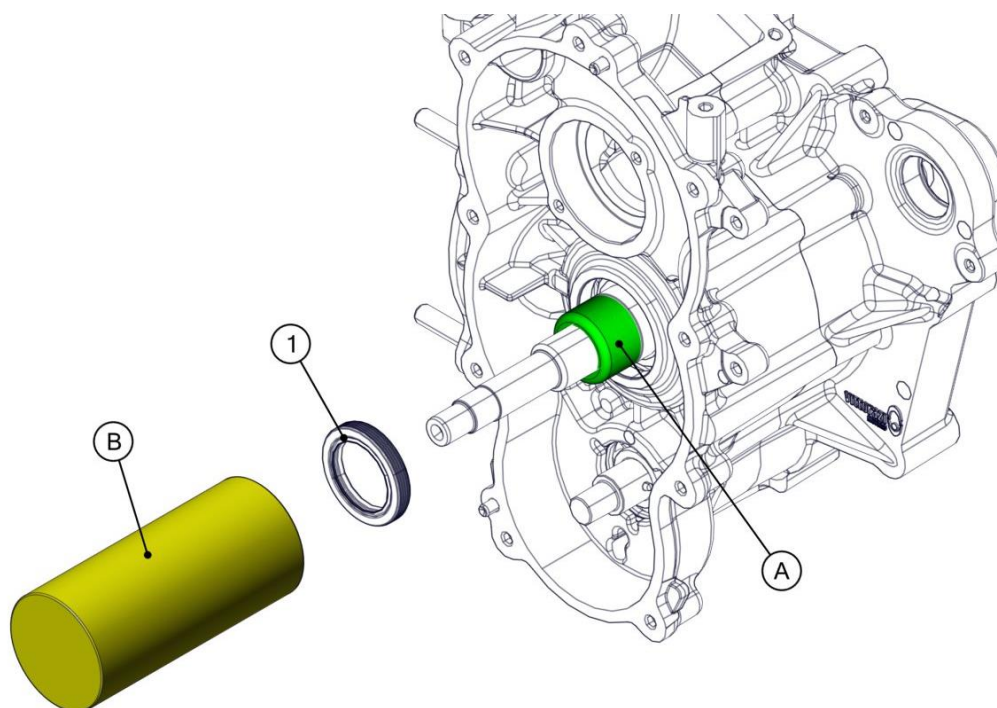

Remove the part B and A.

Check the tightening of screws.
Insert oil into the 2 lubrication holes (highlighted in the figure).

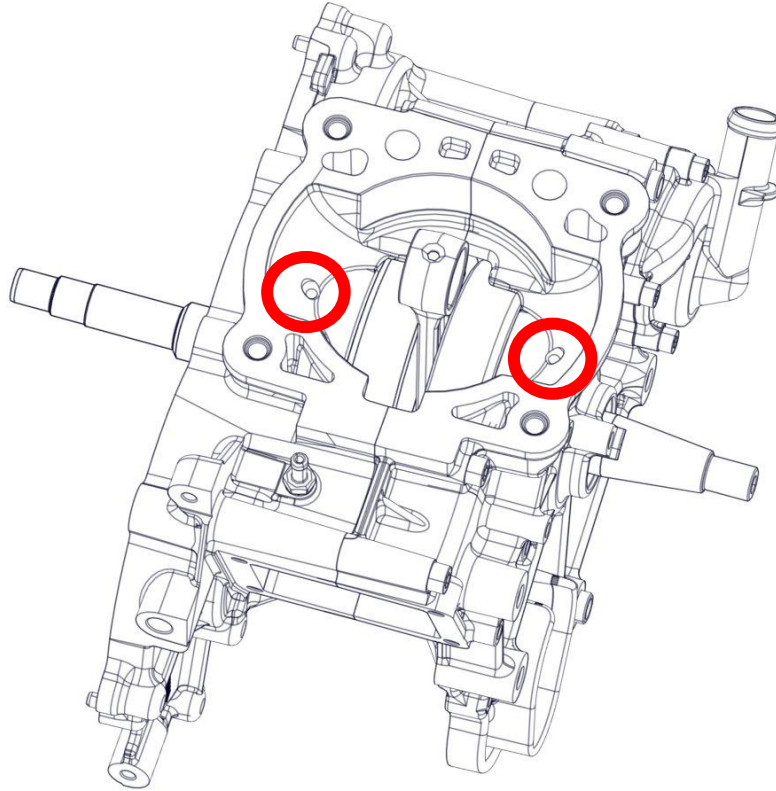

Check the sliding of shafts on the bearings.

3.16 Tightening values

Component	Torque value	Thread size	Lubricant/ sealant
Engine carter screws	10 Nm	M6x50	
Carter support screws	20 Nm	M8x55	
Cylinder studs	20 Nm	M8	
Cylinder nuts	17 Nm	M8	
Cylinder head screws	10 Nm	M6x30	
Spark plug	25 Nm	M14x1,25	
Exhaust studs	25 Nm	M8	Loxreal 83-55/ Loctite 270
Exhaust nuts	32 Nm	M8	Copper paste
Exhaust support plate's nuts	18 Nm	M8	
Silencer fixing screws	13 Nm	M8	
Carburettor flange screws	10 Nm	M6x30	
Carburettor screws	hand tightening	M6x16	Loxreal 83-55/ Loctite 270
Carburettor flange studs	10 Nm	M8	Loxreal 83-55/ Loctite 270
Self-locking nuts	16 Nm	M8	
Screw fixing safety band support plate	8 Nm	M5x20	Loxreal 55-03/ Loctite 243
Snaplock airbox pivots	10 Nm	M6	Loxreal 55-03/ Loctite 243
Airbox fixing clamp	2,5 Nm	50-70 mm (clamp size)	
Flywheel nut	90 Nm	M12x1,25	
Stator screws	10 Nm	M6x25	

The table follows in the next page

Aluminium toothed pulley's screws	10 Nm	M6x20	Loxéal 55-03/ Loctite 243
Pick up screws	8 Nm	M5x12	
Transmission carter screws	10 Nm	M6x30	
Propeller hub fixing screw	28 Nm	M8	Loxéal 55-03/ Loctite 243
Clutch nut	100 Nm	M14x1,5	
Counter-rotating shaft nut	72 Nm	M12x1,25	
Clutch plate screws	8 Nm	M5x14	
Manual starter screws	10 Nm	M6x25	Loxéal 24-18/ Loctite 222
Starter central pin screw	17 Nm	M8x25	Loxéal 83-55/ Loctite 270
Starter aluminium bushing	12 Nm	M12x1,25	Loxéal 55-03/ Loctite 243
Water pump cover screws	8 Nm	M5x20	
Pump impeller nut	8 Nm		
Electric starter screws	10 Nm	M6x35	
Electric starter fixing plate's screws	10 Nm	M6x20	
Pipe support bracket screws	10 Nm	M6x14	Loxéal 83-55/ Loctite 270
Pinion bearing screws	4,5 Nm	M4x8	
Oil level screw	3 Nm	M5x10	
Cylinder vent screw	3 Nm	M5x10	
Water pump lower screw	3 Nm	M5x10	

The table follows in the next page

Thermostat screws	3 Nm	M5x10	
Bearing retainer screws	5 Nm	M5x12	
Carbon propeller screws	12-14 Nm	M8	

